

TECHNO ECONOMIC FEASIBILITY REPORT

for

Expansion of 0.064 MTPA Sponge Iron to 0.19 MTPA Sponge
Iron with 18 MW Power Plant

of

SHIVAM IRON & STEEL CO LTD

IBANDI DIGDHU, CHANDWARA, JHUMRI TELAIYA, JHARKHAND



Prepared by



GLOBAL TECH ENVIRO EXPERTS PVT. LTD.

C-23, BJB NAGAR

BHUBANESWAR-751014

PH. NO.-06742433487

Email:- globalexerts@rediffmail.com

TABLE OF CONTENTS

CHAPTER-1	4
EXECUTIVE SUMMARY	4
CHAPTER-2	8
INTRODUCTION OF THE PROJECT	8
2.1 IDENTIFICATION OF PROJECT & PROJECT PROPONENT	8
2.2 BRIEF DESCRIPTION OF NATURE OF THE PROJECT	8
2.3 IMPORTANCE OF THE PROJECT TO THE COUNTRY AND REGION.....	8
2.3.1 DOMESTIC SCENARIO	9
2.3.2 GLOBAL STEEL SCENARIO.....	12
2.4 EMPLOYMENT GENERATION DUE TO PROJECT	12
2.5 METHODOLOGY OF THE STUDY	12
2.6 ENVIRONMENTAL MANAGEMENT PLAN:.....	14
2.7 LITIGATION/COURT CASE AGAINST THE COMPANY.....	16
2.8 AUTHORIZATION.....	16
2.9 ACKNOWLEDGEMENT:	16
CHAPTER-3	17
PROJECT DESCRIPTION.....	17
3.1 TYPE OF PROJECT INCLUDING INTERLINKED AND INTERDEPENDENT PROJECTS IF ANY.....	17
3.2 LOCATION OF THE PROJECT.....	17
Fig 3.1 Map showing general location, specific location.....	17
3.3 DETAILS OF ALTERNATE SITES.....	19
3.4 SIZE OR MAGNITUDE OF OPERATION	19
3.5 PROCESS DESCRIPTION	20
Table 3.1: Project Configuration	22
3.6 ANNUAL RAW MATERIAL INVENTORY.....	23
3.7 WATER REQUIREMENT.....	24
3.8 MANPOWER.....	24
CHAPTER-4	25
SITE ANALYSIS	25
4.1 CONNECTIVITY.....	25

4.2	LAND.....	25
4.3	TOPOGRAPHY.....	25
	Fig 4.1: Toposheet No G 45 T 7 showing project location.....	26
4.4	LAND USE PATTERN.....	26
CHAPTER-5		31
PLANNING BRIEF		31
5.1	PLANNING CONCEPT	31
5.2	POPULATION PROJECTION.....	31
5.3	LAND USE PLANNING	31
5.4	ASSESSMENT OF INFRASTRUCTURE DEMAND	32
5.5	AMENITIES/FACILITIES.....	32
CHAPTER-6		33
PROPOSED INFRASTRUCTURE.....		33
6.1	INDUSTRIAL AREA.....	33
6.2	RESIDENTIAL AREA.....	33
6.3	GREEN BELT	33
6.4	INDUSTRIAL WASTE MANAGEMENT	33
6.5	SOLID WASTE MANAGEMENT	33
6.6	POWER REQUIREMENT & SUPPLY/SOURCE	34
CHAPTER-7		35
PROJECT SCHEDULE & COST ESTIMATE.....		35
7.1	PROJECT COST	35
7.2	PROJECT COMPLETION SCHEDULE	35

CHAPTER-1 EXECUTIVE SUMMARY

INTRODUCTION

M/s Shivam Iron & Steel Company Ltd. Is located at Bandi Dighu, PO: Chandwara, Jhumri Telaiya, Koderma in the state of Jharkhand, at Latitude **24° 24' 49.55" N** and longitude **85° 28' 59.87" E** with **387m** AMSL.

The unit is running with 2x100 TPD DRI Kilns and producing and selling 64,000 TPA sponge Iron.

The company now proposing to install additional 1x100 TPD & 1x300 TPD DRI kilns and enhance production capacity, install 12 MW power plant based on recovery of waste heat from DRI kiln flue gas, and install 6 MW AFBC.

Mr. Arun Kumar Agarwala is promoter cum director of M/s Shivam Iron & Steel Co Ltd & No, litigation or court cases are pending against the project and/or no direction/order has been passed by any court of law against the project.

India has vast natural resources of good quality iron ore and poor quality non-coking coal, both abundantly available. These two resources can be profitably exploited producing sponge iron.

Sponge Iron is substitute of Iron scrap and production of steel from sponge iron requires less investment than Blast Furnace route and plant does not take much time to give production.

The project location is well connected with road & rail. The AH-42 Ranchi Patna Road is only 0.5 Km away from the project site

LAND

Land in possession is 22.837 Ac. (9.24 ha) on which existing two sponge Iron plants are running and expansion is proposed on the vacant spaces available on this 9.24 ha land utilising infrastructure facilities. Hence alternative sites have not been taken into consideration.

WATER

Make up water requirement for the project is 590m³/day. DRI kilns require minimum water, but AFBC will require more water for condensate cooling.

POWER

Power requirement for the project is about 4MW and captive generation is 18 Mw, so balance power is to be sold to Jharkhand state power grid.

Power saving measures will be taken. LED light will be used for room lighting. Solar lights will be used for street lighting. VFD to be used for ID fans.

MANPOWER

Direct employment of the project including existing will be 300 with contract labour engagement to the same tune.

PROCESS DESCRIPTION

The existing running project has 2x100 TPD DRI kilns and in expansion one more 100TPD and another 1x300 TPD DRI kilns have been proposed. In all the 4 nos of kilns Hematite Iron lumpy ores will be directly reduced by DRI grade coal. This reduction being exothermic process, a lot of heat will be generated which will be carried out of the kiln along with unburnt carbon and CO. This will be burnt in ABC with external supply of air and temperature will increase.

This otherwise waste heat will be utilised in boiler to generate medium pressure steam. Steam will rotate generator to generate 12MW power.

Sponge iron produced is cooled and magnetically separated from dolchar, ash and kiln accretion and stored for sale.

Dolchar is burnt with fresh coal support in AFBC to produce steam and there by 6MW power will be generated.

RAW MATERIAL REQUIREMENT FOR THE PROJECT

Annual Raw material requirement for the project will be Iron ore 3,10,000T, DRI grade coal 2,70,000T, Boiler grade coal 30,000T to support dolchar burning and 8,000T of dolomite/Lime stone.

TOPOGRAPHY

The section line from south to north from Jharkhand to Bihar passing through Hazaribag plateau. Buffer zone of the project area is just above Hazaribag. The rock at the edge of this plateau has been cut deeply by innumerable streams. There are a number of rills & gullies of various type such as figure or shoe-lace gullies.

The area exhibits undulating topography comprising hills, hillocks, mounds and plains. Valley fills with low to moderate frequency of lineaments, Pedi plains with moderate frequency of lineaments and Pedi plains are major geomorphological units of the district. Concentrations of lineaments are more in Chandwara in which the project is located.

RIVER AND WATER BODIES

Barakar River flows from W to E in the southern part of the district of Koderma and supports Telaiya Hydel project, a multipurpose dam construction on it. River flows from West to East Poanchkhara, Keso, Akto, Gurio, Gukhana Nadi are the main tributaries of the Barakar river.

SOIL CHARACTERISTIC OF BUFFER ZONE

The soil of the project study area is laterite soil. This soil is characterized by its acidic nature and not suitable for traditional agriculture. Most of the land is usar land. Land Use Due to the laterite condition of the soil, deficiency in rainfall, and no major rivers the land use pattern is different from the Gangetic plain. Some irrigated area takes into account of rabi, kharif and oilseeds crops. But generally it is best suited for vegetables, medicinal plants growing and floriculture due to natural drainage of water and no waterlogging conditions

CLIMATIC DATA FROM SECONDARY SOURCE

The climate of Koderma can be described as a transition between the dry and moderately extreme climate of the northern India and the warm, humid climate of Bengal Basin. The climatic year of Koderma district can be divided into four principal seasons.

Its climate is moderately hot and humid. The average rain fall is 1192 mm and the temperature ranges from 4°c in winter to 42°c in summer.

SOCIAL INFRASTRUCTURE AVAILABLE

As per the 2011 census the total number of literates in Chandwara CD Block was 43,936 (63.75% of the population over 6 years) out of which males numbered 27,432 (76.82% of the male population over 6 years) and females numbered 16,504 (49.69% of the female population over 6 years). The gender disparity (the difference between female and male literacy rates) was 27.13%.

As per the 2011 census, literacy in Koderma district was 66.84%, up from 52.20% in 2001. Literacy in Jharkhand (for population over 7 years) was 66.41% in 2011. Literacy in India in 2011 was 74.04%.

The 79.7 km long first stage railway project from Koderma to Hazaribagh costing Rs. 936 crore was inaugurated by Prime Minister Narendra Modi on 20 February 2015. The railway line passes through this CD Block and there are stations at Pipradih and Urwan.

About 41% part of the Koderma district is covered with forests. The total forest area of Koderma district is 64796.90 hectare is scattered in 309 forest villages as protected

forest under administrative control of Koderma Forest Division together with 15062.77 hectare scattered in 35 forest villages as a reserved forest.

The per capita forest area in hectare is 0.14. Sal is the main forest crop together with Bija, Gamhar, Khair, Palash, Salai, Semal, Bair, Arjun, Karam, Siris, Kaj, Kend, Mahulan, Mahua, Karanj, Ratti etc. Koderma forest area having Barakar, Sakri, Dhadhar and Telaiya River are the main river of koderma forest.

Solid waste Management

Dolchar produced as waste material from DRI kilns will be burnt in AFBC to generate power for the plant. Fly ash from AFBC will be supplied free of cost to brick manufacturing plants. Bottom ash can be given to cement plants or will be used as land fill material.

The Solid wastes will be treated as by products and these will be fully utilized.

Waste water management

Waste water from DRI kilns will be reused after cooling. Waste water from AFBC will be settled, treated and recycled to process. There will be zero waste water discharge out side plant boundary.

POLLUTION CONTROL MEASURES

To control dust emissions from DRI kilns and AFBC ESPs with ID fan and high stack will be used. On line monitoring of stack emission will be ensured. DG sets will have stack extended above the roof as per guide line of CPCB.

Acoustic covers will be used on sound producing machines. Silent type DG sets will be used.

Personal protective appliances to be provided to workmen.

PROJECT COST & COMPLETION SCHEDULE

Project cost has been estimated to be 190 crores. Own financial source will be utilized.

Project will be completed within 18 months of time after getting prior EC.

CHAPTER-2 INTRODUCTION OF THE PROJECT

2.1 IDENTIFICATION OF PROJECT & PROJECT PROPONENT

M/s Shivam Iron & Steel Company Ltd. Is located at Bandi Dighu, PO: Chandwara, Jhumritelaiya, Koderma in the state of Jharkhand, at Latitude **24° 24' 49.55" N** and longitude **85° 28' 59.87" E** with **387m** AMSL.

The unit is running with 2x100 TPD DRI Kilns and producing and selling 64,000 TPA sponge Iron. The company now proposes to install additional 1x100 TPD & 1x300 TPD DRI kilns and enhance production capacity of sponge Iron to 1,92,000 TPA for sale. The proposal is also for installation of 12 MW power plant based on waste heat recovery from DRI kiln flue gas, and installation of 6 MW AFBC power plant utilising dolchar rejects of DRI kilns with fresh coal support.

M/s Shivam Iron & Steel Co Ltd. was incorporated on 16th September 1998. It is now a well-established company with its another running unit manufacturing TMT rods and Ferro-alloys at Jambadin Giridh district of Jharkhand.

Mr. Arun Kumer Agarwala is promoter cum director of M/s Shivam Iron & Steel Co Ltd with three other directors namely Mr. Binod Kumar Agarwala, Mr. Pramod Kumar Agarwala and Mr. Shiva Kumar Agarwala.

2.2 BRIEF DESCRIPTION OF NATURE OF THE PROJECT

The project after proposed expansion will be a sponge Iron producing unit with 1x300 TPD and 3x100 TPD DRI Kilns and hence comes under category-A.

DRI kilns of expansion project will be set up on the existing land of running unit and solid waste like dolchar to be stored for sale to power plants.

2.3 IMPORTANCE OF THE PROJECT TO THE COUNTRY AND REGION

India has vast natural resources of good quality iron ore and poor quality non-coking coal, both abundantly available. These two resources can be profitably exploited producing sponge iron. This promises a new era when India could once again produce the cheapest steel in the world within the next 25 year if all our endeavours are focussed on the Sponge Iron Process with zeal, assiduity and determination to bring about and hasten the new Breakthrough in Iron and Steel Technology as early as possible. Many of our future steel plants would then have large Sponge Iron Plants. Steel is a basic commodity for all industrial activity and its consumption marks industrial prosperity. The steel industry has tremendous forward and backward linkages in terms of material flow, income and employment generation.

Sluggish demand for finished steel products amid stubborn iron ore rates in the domestic market is giving sponge iron producers a tough time.

The market for sponge iron has been further dented with steel makers preferring imported steel scraps to sponge iron to cut production cost. Besides, traders find it competitive to buy finished steel than producing it,

Metal scraps are easy to melt and require less fuel. Since scrap rates have come down globally and are competing with sponge iron in the domestic market, buyers are preferring scrap and Imported steel scraps available at Indian ports between Rs 18,000 and Rs 19,000 a tonne, around similar levels at which sponge iron makers are offering their products.

Restrictions and court orders to ban iron ore mining in Odisha, the top iron ore producing state has pushed down domestic iron ore output.

However, with the opening up of key mines in Odisha, raw material rates would fall, said sponge iron producers. They added that the products would once again have competitive advantage than scrap.

Steel is a core industry and thus its demand is strongly linked to the overall economic activity of the nation. Given the inherent long-term potential of the Indian economy and its cyclical nature, the long-term prospects of the steel industry are fairly comfortable.

It has been estimated by certain major investment houses such as Credit Suisse that India's steel consumption will continue to grow at 16 % rate annually fuelled by demand for construction projects worth US \$1 trillion. The scope for raising the total consumption for steel is huge, Per capita consumption of steel at current levels is about 65 kg. As a comparison per capita steel consumption in China is 430 kg and the world steel consumption per capita average is 180 kg.

By 2020-21 the demand at 7 % and 8 % GDP growth is estimated to be 123 million tons and 137.5 million tons respectively. Taking a mean figure of 130 million ton, there is a need of 65 million ton in 10 years time. This translates into an average growth requirement of about 10 million tons per year.

So there is future for sponge Iron Industries.

2.3.1 DOMESTIC SCENARIO

- The Indian steel industry has entered into a new development stage from 2007-08, riding high on the resurgent economy and rising demand for steel.
- Rapid rise in production has resulted in India becoming the 3 rd largest producer of crude steel in 2015 and the country continues to be the largest producer of sponge iron or DRI in the world.

As per the report of the Working Group on Steel for the 12th Five Year Plan, there exist many factors which carry the potential of raising the per capita steel consumption in the country. These include among others, an estimated infrastructure investment of nearly a trillion dollars, a projected growth of manufacturing from current 8% to 11-12%, increase in urban population to 600 million by 2030 from the current level of 400 million, emergence of the rural market for steel currently consuming around 10 kg per

annum buoyed by projects like Bharat Nirman, Pradhan Mantri Gram Sadak Yojana, Rajiv Gandhi Awaas Yojana among others.

India produced 88.97 mt , 89.79 mt and 96 mt of crude steel during 2014, 2015 and 2016 respectively. India's steel exports grew 150.0 per cent year-on-year to 0.75 MT in February 2017, while steel imports declined 46 per cent year-on-year to 0.49 MT. Total consumption of finished steel grew by 3.4 per cent year-on-year to 76.22 MT during April 2016-February 2017.

This was on account of higher output by the major Indian steel companies. The imposition of Minimum Import Price (MIP) encouraged the producers to increase their output. Care Ratings said that the consumption of steel, on the other hand, grew by just 3.2% to 73.75 MT during April-December 2016.

The National Steel Policy 2017, released by the government, aims to increase steel production. Thus, both production and consumption of steel is expected to remain buoyant in 2017-18, the report said.

More steel production will demand more sponge iron.

Government Initiatives

Some of the other recent government initiatives in this sector are as follows:

- The Government of India has approved a joint venture (JV) between MSTC Ltd and Mahindra Inter trade Ltd, for setting up India's first green field auto shredding and recycling facility, which will aide in saving of foreign currency, as a result of import substitution of scrap.
- Union Minister of Steel, Mines, Labor and Employment, has launched the National Mineral Exploration Policy (NMEP), which will help to adopt comprehensive exploration of non-fuel and non-coal mineral resources that would give a major boost to the economy.
- Metal Scrap Trade Corporation (MSTC) Limited and the Ministry of Steel have jointly launched an e-platform called 'MSTC Metal Mandi' under the 'Digital India' initiative, which will facilitate sale of finished and semi-finished steel products.
- The Parliament of India has cleared amendments to the Mines and Minerals Development and Regulation (MMDR) Act, which will enable companies to transfer captive mines leases similar to mines won through an auction, and which is expected to lead to increased Mergers and Acquisitions (M&A) of steel and cement companies.
- The Ministry of Steel has announced to invest in modernization and expansion of steel plants of Steel Authority of India Limited (SAIL) and Rashtriya Ispat Nigam Limited (RINL) in various states to enhance the crude steel production capacity in the current phase from 12.8 MTPA to 21.4 MTPA and from 3.0 MTPA to 6.3 MTPA respectively.

- The Minister of Steel & Mines has reiterated commitment of Central Government to support the steel industry to reach a production target of 300 Million Tonne Per Annum (MTPA) in 2025.
- The Ministry of Steel is facilitating setting up of an industry driven Steel Research and Technology Mission of India (SRTMI) in association with the public and private sector steel companies to spearhead research and development activities in the iron and steel industry at an initial corpus of Rs 200 crore (US\$ 30 million).
- The Central Board of Excise and Customs (CBEC) has issued a notification announcing zero export duty on iron ore pellets, which will help the domestic industry to become more competitive in the international market.
- Government has planned Special Purpose Vehicles (SPVs) with four iron ore rich states i.e., Karnataka, Jharkhand, Orissa, and Chhattisgarh to set up plants having capacity between 3 to 6 MTPA.
- SAIL plans to invest US\$ 23.8 billion for increasing its production to 50 MTPA by 2025. SAIL is currently expanding its capacity from 13 MTPA to 23 MTPA, at an investment of US\$ 9.6 billion.

Some of the major investments in the Indian steel industry are as follows:

- Tata Steel has signed an agreement to purchase a majority 51 per cent stake in Creative Port Development (CPDPL), which has a concession agreement with the Odisha government to develop a 10 million-tonnes-per-annum (MTPA) Subarnarekha port at Chamukh village in Balasore district of Odisha.
- Tidfore Heavy Equipment Group, the China-based infrastructure giant, is looking to enter the Indian market by signing an investment agreement worth US\$ 150 million with Uttam Galva Metallics, to expand its Wardha unit along with South Korean steel major Posco.
- Arcelor Mittal SA is looking to set up a joint venture (JV) factory in India with state-owned Steel Authority of India Ltd (SAIL), to manufacture high-end steel products which could be used in defence and satellite industries.
- JSW Group plans to invest around Rs 10,000 crore (US\$ 1.5 billion) at Salboni in West Bengal to set up 1,320 Megawatt (MW) coal-based power plant, 4.8 million tonne cement plant and paints factory over a period of next five to seven years.
- National Mineral Development Corporation (NMDC) has planned to invest Rs 40,000 crore (US\$ 6 billion) in the next eight years to achieve mining capacity of 75 Million Tonnes Per Annum (MTPA) by FY2018-19 and 100 MTPA by FY2021-22, compared to 48 MTPA current capacity.
- Posco Korea, the multinational Korean steel company, has signed an agreement with Shree Uttam Steel and Power (part of Uttam Galva Group) to set up a steel plant at Satarda in Maharashtra.
- Arcelor Mittal, world's leading steel maker, has agreed a joint venture with Steel Authority of India Ltd (SAIL) to set up an automotive steel manufacturing facility in India.
- Iran has evinced interest in strengthening ties with India in the steel and mines sector, said ambassador of the Islamic Republic of Iran, Mr Gholamreza Ansari in his conversation with Minister of Steel and Mines, Mr Narendra Singh Tomar.

- Public sector mining giant NMDC Ltd will set up a green field 3-million tonne per annum steel mill in Karnataka jointly with the state government at an estimated investment of Rs 18,000 crore (US\$ 2.7 billion).
- JSW Steel has announced to add capacity to make its plant in Karnataka the largest at 20 MT by 2022.

2.3.2 GLOBAL STEEL SCENARIO

- Steel production in the world is dominated by China followed by Japan. In 2016, the world crude steel production reached 1628 million tonnes (MT) and showed a growth of 0.8% over 2015.
- China remained world's largest crude steel producer in 2016 (808 MT) followed by Japan (105 MT), India (96 MT) and the USA (79 MT).
- World Steel Association has projected Indian steel demand to grow by 5.4% in 2016 and by 5.7% in 2017 while globally, steel demand has been projected to grow by 0.2% in 2016 and by 0.5% in 2017. Chinese steel use is projected to decline in both these years - by 1% in 2016 and by 2% in 2017.
- Per capita finished steel consumption in 2015 is placed at 208 kg for world and 489 kg for China by World Steel Association

Steel is a key driver of the world's economy. The industry directly employs more than two million people worldwide, with a further two million contractors and four million people in supporting industries. According to the World Steel Dynamics (WSD) organization, global steel production (as also demand for it or consumption) will grow at an annual average compounded rate of growth of 1.28 per cent during 2015-2025 to reach only 1873 million tonnes by 2025. Other well known forecasts, this figure was to be achieved by 2020.

[Source: Ministry of Steel]

2.4 EMPLOYMENT GENERATION DUE TO PROJECT

The project will plan to give more employment opportunities to skilled & unskilled workers by Direct & Indirect Employment. The total man power requirement for plant operation on completion of the proposed expansion will be around 300 including 200 employees of the existing unit. Besides this some contractual workers are to be employed to manage canteen, security and housekeeping during construction as well as operation phase.

2.5 METHODOLOGY OF THE STUDY

Environmental issues must be addressed during project planning before the actual project is executed. In the same way as economic, financial, institutional, or technical analysis, Environmental Impact Assessment (EIA) is an integral part of the project. EIA is the process in which environmental factors are integrated into project planning and decision-making so as to achieve ecologically sustainable development. Best-practice EIA identifies environmental risks, lessens conflicts by promoting community participation, minimizes adverse environmental effects, informs decision makers, and helps lay the base for environmentally-sound projects. Benefits of integrating EIA have been observed in all stages of a project, from

exploration and planning, through construction, operations, decommissioning, and beyond site closure.

The process of EIA usually consists of the following stages:

- Screening
- Scoping
- Baseline Study
- Environmental Impact Identification, Prediction and Assessment.
- Environmental Management Plan
- Decision making relative to the proposed action.
- Study Documentation

Screening: Assessment the need for an EIA. Whether there is any possibility of significant stress or shock on the supportive and assimilative capacity of the surrounding environment.

Scoping: Identification of issues and impacts to be considered in the EIA study

Baseline Study: Conducting necessary field studies for generation baseline data to define the pre-project environment. The baseline study has been done as per the approved TOR conditions given by MoEF.

- For Impact Prediction and Assessment, the details of most of the baseline data is collected during the study period of 03 months to be undertaken from December to February. There is elaborate data collection with respect to geology, geomorphology, hydrogeology, drainage pattern; land use pattern etc. and the subsequent satellite map will be prepared with a 10 km radius buffer zone.
- Details of the micro-meteorological data is collected with respect to hourly wind speed & wind direction, humidity, temperature, cloud cover, rainfall data etc. The corresponding frequency distribution of wind behaviour with wind rose diagram is prepared. This will form the meteorological data input to Air Quality Prediction Model.
- The existing ground level concentration of Particulate Matter (PM10 and PM2.5), Sulphur Dioxide (SO₂), Nitrogen Oxide (NO_x) and Carbon Monoxide (CO) are analyzed during the study period in the core zone as well as buffer zone including at least one in the down wind direction. The air sampling location and others will be chosen studying the wind rose and using standard procedures.
- Surface water & ground water analysis is done in core zone and buffer zone as per the parameters in relevant standard.
- The soil testing is done in core and buffer zone.
- The average noise quality both in day and night.
- All the procedure of collection of sample, frequency of collection, analysis procedures etc are done as per CPCB norms.
- Details of the ecological survey are taken up with respect to flora and fauna including avifauna and aquatic fauna with an emphasis on endangered species in the core zone as well as in the buffer zone.
- Socio-economic data of the region is collected with respect to literacy, economic status, occupation, living standard, health etc. of the local population. There are

detailed data collections about infrastructure facilities like transportation, communication, education health etc.

- Detailed survey of the 15 Km. region around the project is conducted to find out any location of sensitive areas like wild life sanctuaries, historical & archaeological sites, defence installations etc.

Environmental Impact Identification, Prediction and Assessment

- Different environmental impact areas are identified and expressed in matrix form.
- Qualitative prediction of impact is done with respect to land use, ecology and noise and socio-economic.
- Details of water and waste water inventory are prepared to find out their impact on the environment.
- Solid wastes Inventory (both hazardous and non-hazardous in nature) is done to predict and assess their impact on environment.
- Detailed information about stacks with respect to height, diameter, flue gas, temperature, velocity and flow and the inter stack distances is provided.
- Emission inventory with respect to PM, SO₂, NO_x is calculated.
- Micro-meteorological data along with stack and emission inventory data is input to the air quality prediction modelling software.
- Quantitative prediction of air pollutants in the form of incremental ground level concentration (GLC) is done by Air Quality Prediction Modelling Software (ISC-AEROMOD-ISCST-3) developed by USEPA.
- Maximum resultant GLC is calculated at locations taking into consideration of background GLC and predominant wind direction.
- Subjective impact assessment using matrix method is carried out to calculate the total impact score without mitigation measures.

This will be done as per the approved TOR conditions given by MoEF.

2.6 ENVIRONMENTAL MANAGEMENT PLAN:

Following environmental management plan is proposed to reduce the predicted adverse impacts and to make provision to compensate for any residual adverse impact

- Air Pollution control Equipments (APE) to be setup.
- Disposal management of the solid waste and effluents generated from these APC equipments will be chalked out.
- Fugitive dust emission from the different storage & transfer point and haul road emissions and their detailed control aspects shall be covered.

- Considering water as important and valuable utility, company will formulate a water management plan for minimum use of the fresh water.
- Waste water management dealing with treatment methodologies and recycling/reuse of treated waste will be prepared.
- Storage of storm water in the monsoon in water harvesting ponds and the use of the same water in lean season will be planned.
- Zero discharge norms with a comprehensive water and waste water management plan will be evaluated.
- A detail of the solid waste inventory, its characterization and their usage potentiality will be discussed. Solid waste plant process and reuse of the solid waste for different purposes will be examined.
- Noise control devices with different equipments at design stage, protective measures at work zone sites and supply of protective gears to affected personnel will given in detail.
- Realizing the need for the greenbelt cover as a very good sink for pollutants and the aesthetical aspects the company will go for a comprehensive plantation program as per MoEF Norms.
- Detailed plan for greenbelt development with respect to allocation of area, fund allocation, selection of the species and maintenance plan will be covered. Peripheral development plan that includes development in infrastructure, health education and socio-cultural aspects will be emphasized.
- Details of the EMP cell with respect to monitoring laboratory, technical man power and fund allocation is discussed. Details of monitoring program with respect to pollutant parameters. Monitoring scheduled and reporting as per statutory requirement will be planned.
- Safety and disaster management plan with onsite emergency plan to deal with the unforeseen accidents will be covered.
- Beneficial aspects of project with respect to direct and indirect employment, business opportunities and peripheral development will be discussed. Trickle-down effect of all the project benefits to affected local population will be analyzed.
- Taking in to consideration of the environmental degradations due to the project implementation and the consequent environmental management plan followed by the post project benefits, the subjective assessment with a Total Impact Score will be analyzed to draw a summary conclusion.

2.7 LITIGATION/COURT CASE AGAINST THE COMPANY

No, litigation or court cases are pending against the project and/or no direction/order has been passed by any court of law against the project.

2.8 AUTHORIZATION

M/s. Shivam Iron & Steel Co.Ltd has entrusted M/S Global Tech Enviro Experts Pvt. Ltd., Bhubaneswar for the preparation of TEFR for their sponge Iron expansion project. In accordance to the scope of work, M/s. GTEEPL team has visited the project site to take general view and will again will visit the project site and collect base line data like Air, Water, Soil & Noise from the project site and availability of infrastructure facilities like raw materials, water, power and transportation facilities in detail.

The team will also make socio-economic study of 10km buffer zone of the project site to know existing status of the locality and flora & fauna.

2.9 ACKNOWLEDGEMENT:

M/s GLOBAL TECH ENVIRO EXPERTS PVT LTD, Bhubaneswar expresses its deep gratitude to M/s. Shivam Iron & Steel Co. Ltd, Koderma for the assignment entrusted to them.



The corner co-ordinates are: North 24°24'50.91" N 85°29'4.16" E
South 24°24'44.94" N 85°28'51.19" E
West 24°24'52.38" N 85°28'54.93" E
East 24°24'44.39" N 85°29'0.74" E

The location is well connected with road & rail. The AH-42 Ranchi Patna Road is only 0.5 Km away from the project site.

Layout map of project site

Layout map of Project site showing existing facilities, expansion facilities, water reservoir, rain water harvesting pond, solid waste storage yard and green belt etc.

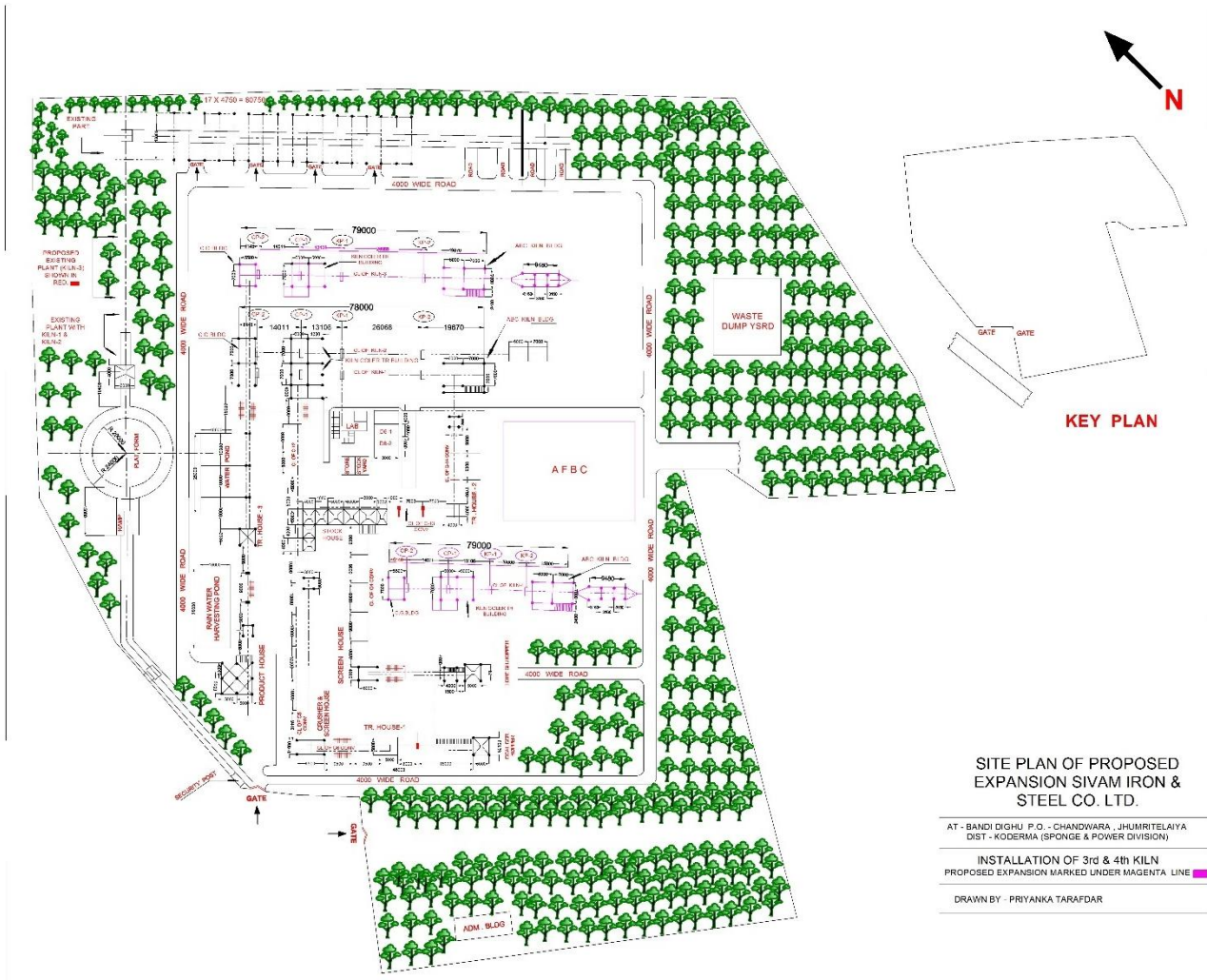

3.3 DETAILS OF ALTERNATE SITES

M/s SISCL existing plant is running on an acquired land and its expansion will be executed in the vacant space available within the existing land. So no alternate site has been taken into consideration.

3.4 SIZE OR MAGNITUDE OF OPERATION

M/s SISCL is at present running with 2x100 TPD DRI kilns and producing 64,000 TPA sponge Iron and now proposing 1x100 TPD and 1x300 TPD DRI kilns to enhance production capacity to 1,92,000 TPA sponge Iron.

The total capital cost of proposed project will be about Rs.190 crores with total direct employment of 300.

3.5 PROCESS DESCRIPTION

DRI kiln

Sponge iron is the metallic form of iron produced from reduction of iron oxide below the fusion temperature of iron ore (1535°C) by utilizing hydrocarbon gases or carbonaceous fuels as coal. The reduced product having high degree of metallization exhibits a 'honeycomb structure', due to which it is named as sponge iron. As the iron ore is in direct contact with the reducing agent throughout the reduction process, it is often termed as direct reduced iron (DRI).

Sponge iron, also known as "Direct Reduced Iron" (DRI) and its variant Hot Briquetted Iron (HBI) have emerged as prime feed stock which replace steel scrap in EAF/IF as well as in other steel-making processes. It is the resulting product (with a metallization degree >85%) of solid state reduction of iron ores or agglomerates (generally of high grade), the principal constituents of which are metallic iron, residual iron oxides, carbon and impurities such as phosphorus, sulphur and gangue (principally silica and alumina). The final product can be in the form of fines, lumps, briquettes or pellets. Sponge iron when briquetted in hot condition at elevated temperature is called hot briquetted iron (HBI).

M/s Shivam Iron & steel co Ltd is proposing 1x100 TPD and 1x300 TPD coal based DRI kilns with SL/RN Technology using Hematite ore and Non-coking coal.

Reduction Process

The charge into the kiln consists of a mixture of iron oxide lump, fluxes such as limestone and/or dolomite (amount depending of sulphur content of the coal) and medium volatile non-coking coal. In the pre-heating zone, the moisture is driven off first, and then the hydrocarbons and hydrogen evolve by thermal decomposition of the coal.

As the combustible gases rise from the bed of solid material, a portion of the gases is burnt in the free board above the bed by controlled quantities of air introduced through the air tubes. As the kiln rotates, the primary mode of heat transfer is by radiation to the tumbling charge and subsequently by internal solids mixing and renewal of the exposed bed surface.

In the pre-heat zone, the reduction of iron oxide proceeds only to ferrous oxide (FeO) (Equation 1).



Final reduction to metallic iron occurs in the metallization zone by reaction of CO with FeO to form CO₂ and metallic iron (Equation II).



Most of the CO₂ reacts with the excess solid fuel in the kiln and is converted to CO according to the Boudouard reaction (Equation III).

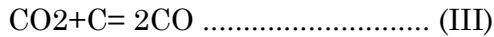

Coals with higher reactivity are preferred as they provide rapid conversion of CO₂ to CO, thereby maintaining reducing conditions in the kiln metallization zone. The highly endothermic reaction of coal with CO₂ prevents the bed from overheating and attaining high temperature that could lead to melting or sticking of the charge.

High coal reactivity decreases the reduction zone bed temperature but increases the relative capacity. Desired bed and gas temperature in the freeboard can be achieved with high reactivity fuels even with very high throughput rates.

Air admitted to the ports below the bed in the pre-heat zone will burn some of the gases that otherwise leave the kiln unburnt to improve fuel consumption

Process flow sheet

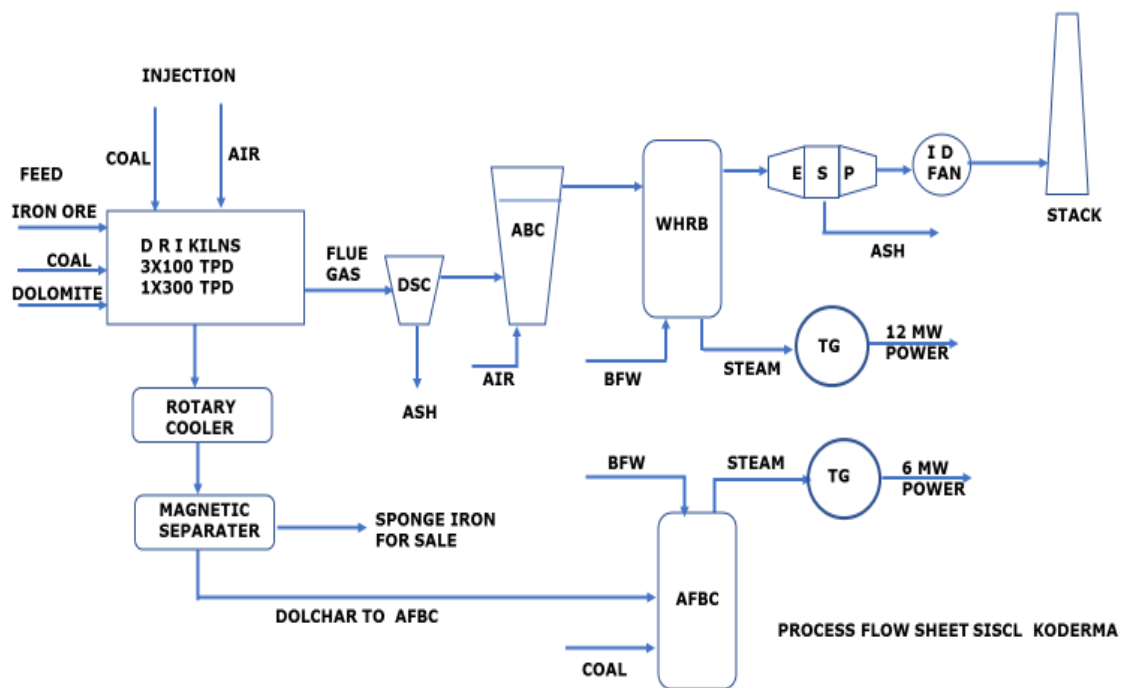

Table 3.1: Project Configuration

Facilities	Existing configuration	Existing Capacity in TPA	Proposed configuration	Proposed capacity in TPA	Final configuration	Final capacity in TPA	Product	End use
DRI Kiln	2x100 TPD	64,000	1 x100 TPD& 1x300 TPD	1,28,000	3 x100 TPD& 1x300 TPD	1,92,000	Sponge iron	Sale
WHRB	Nil	-	1x12 MW	12 MW	1x12 MW	12 MW	Power	Internal consumption
AFBC	Nil	-	1x6 MW	6 MW	1x6 MW	6 MW	Power	Internal consumption

WHRB

After direct reduction inside DRI kiln, flue gas comes out at about 900°C and contains combustibles, so air is given to burn it and there by pollutant CO gas and Carbon particles are completely consumed and temperature goes upto 1050°C.

From 3x100 TPD and 1x300 TPD DRI kilns about 1,50,000 m³/hr of flue gas will come out at about 1050°C, which will be passed through WHRB, where heat can be transferred to water and there by 40-45TPH steam shall be generated at about 65kg/cm² pressure. This steam shall be used to rotate Turbo-generator to generate 12 MW power .

AFBC

After reduction Iron ore to sponge Iron dolchar, having potential calorific value will come out which shall be burnt as fuel in AFBC and generate heat and thereby steam shall be produced to generate power.

From the DRI kilns 90-150 TPD dolchar having calorific value 1500-1800 kcal/kg will come out as by-product. This will be burnt along with fresh coal in AFBC. On full utilisation of dolchar with fresh coal support 20-24 TPH steam can be produced at 65kg/cm² pressure and from that 6MW power can be generated. It is calculated that 2.9MW will be share of power from dolchar. Hence with about 70TPD fresh coal support 6 MW power can be generated.

3.6 ANNUAL RAW MATERIAL INVENTORY

The estimated gross annual quantity of major raw materials to be handled and their mode of receipt are tabulated in Table below

Materials	Gross quantity in TPA	Source	Mode of Transport
Boiler grade Coal	30,000	Eastern Coal Field Ltd	Rail / Road
DRI grade Coal	2,70,000	Eastern Coal Field Ltd	Rail / Road
DRI grade Iron Ore	3,10,000	Barbil & Banspani,	Rail / Road
Dolomite/Lime stone	8,000	Biramitrapur	Rail / Road

Material will be transported fully covered and through environmentally compliant Bharat-III/ Euro-III vehicles

In addition to the above indicated major raw materials LDO/HSD, & lubricating oil will also be required to be purchased as every start-up of DRI kiln LDO/HSD will be required.

3.7 WATER REQUIREMENT

Water will be required to control temperature rise in various process. There will be circulating water in close or open circuit. Non-contaminated water will be reused in the process after cooling. Contaminated water will be settled, treated, filtered and reused and there by fresh water requirement will be reduced. Loss of water as non-recoverable waste water and through evaporation are to be made up to circulating circuit as fresh make up water.

Sl. No	Facilities	Make up water requirement Cum/day
1	1 X 300TPD, 3 X 100TPD, DRI plants	45
2	Captive power plant 18 MW with air or mixed cool condenser	520
3	Domestic & AC use	25
	Total water requirement	590

3.8 MANPOWER

It is estimated that the total requirement of direct employment manpower for the including facilities proposed will be about 300 persons and about similar number of contract labourers will be engaged for security, housekeeping and canteen services.

CHAPTER-4 SITE ANALYSIS

4.1 CONNECTIVITY

The existing sponge iron plant project site is located at Bandi Dighu, Jhumritelaiyain Koderma district of Jharkhand. The area is industrially developed and has necessary infrastructure facilities such as motorable road up to the project site. Koderma Rly. stn is 5.5km from project site and Jhumritelaiya is 4nm.AH 42, previously NH 31

4.2 LAND

The total land acquired by M/s Shivam Iron & Steel Co. ltd is 22.837 Ac. (9.24 ha) vide Khata No-1,4,5&6 and Plot No-15 to 18, 26 & 30 to 40.

4.3 TOPOGRAPHY

The site is geographically located at $24^{\circ} 24' 49.55''$ Nand longitude $85^{\circ} 28' 59.87''$ E with 387m AMSL. The area mostly is a plain area. The nearby industries of M/s Shivam Iron & Steel Co. Ltd are:

The section line from south to north from Jharkhand to Bihar passing through Hazaribag plateau. Buffer zone of the project area is just above Hazaribag. The rock at the edge of this plateau has been cut deeply by innumerable streams. There are a number of rills & gullies of various type such as figure or shoe-lace gullies.

The area exhibits undulating topography comprising hills, hillocks, mounds and plains. Valley fills with low to moderate frequency of lineaments, Pedi plains with moderate frequency of lineaments and Pedi plains are major geomorphological units of the district. Concentrations of lineaments are more in Chandwara, Koderma and Jainagar blocks. Upper part of Chandwara block consists of dissected plateau and lowest part by pediplain. Saluja Steel. The entire district as well as the project area is underlain by the rocks of wide variety of geological formation ranging in age from Archean to Recent. The main being Archean proterozoic, pemocarboniferous and recent.. Phyllite, Mica Schist, Granite gneiss and intrusive granite are the main geological formation of the district. Sporadic occurrence of Dolerite, Quartz pegmatite veins and Quartzites are also found. Thin deposits of alluvium are found along the course of rivers.

In Chandwara block depth to water level becomes deeper from north to south. In northern portion the depth to water level varies between 3-5 mbgl where as in southern portion it varies between 7-10 mbgl in pre-monsoon period where as post-monsoon depth of water level varies between 2-3 mbgl.

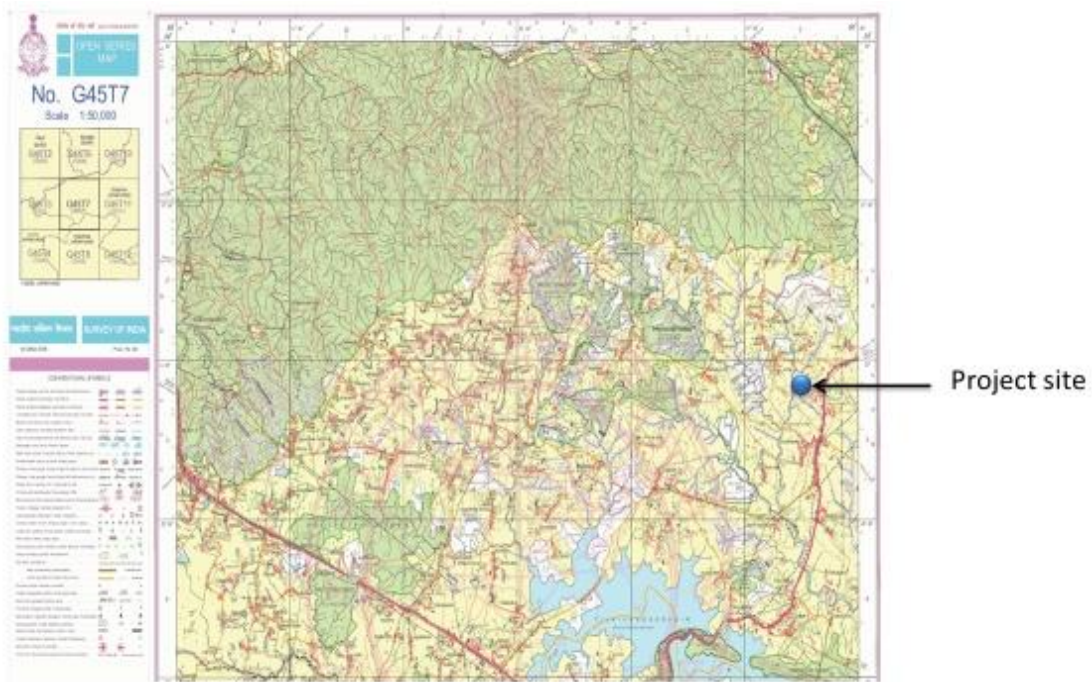
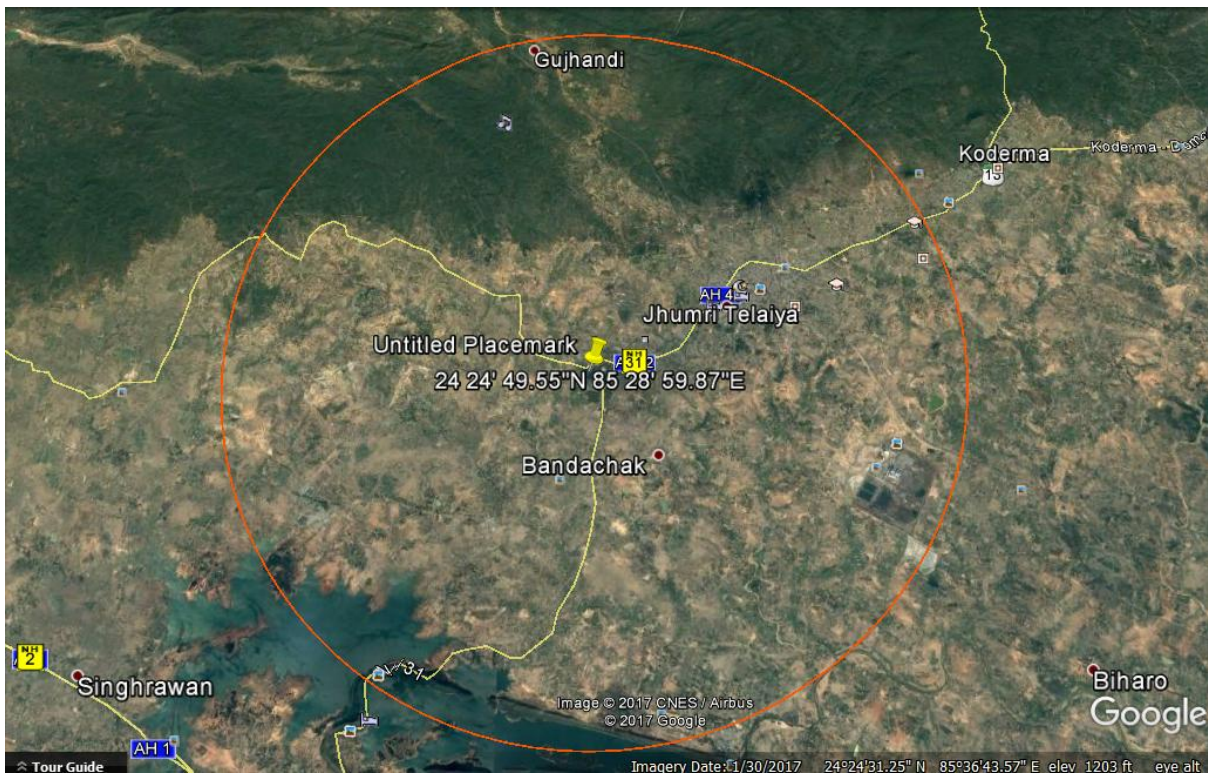

Fig 4.1: Toposheet No G 45 T 7 showing project location

4.4 LAND USE PATTERN



River and water bodies

Barakar River flows from W to E in the southern part of the district of Koderma and supports Telaiya Hydel project, a multipurpose dam construction on it. River flows from West to East Poanchkhara, Keso, Akto, Gurio, Gukhana Nadi are the main tributaries of the Barakar river.

Soil characteristic of buffer zone

The district forms the northern edge of the chhotanagpur plateau. Topography of the district is hilly. Upland covers major part of cultivable land, but due to inadequate irrigation facility only one crop namely paddy is grown, however multi cropping pattern is adopted in a few area.

The soil of the project study area is laterite soil. This soil is characterized by its acidic nature and not suitable for traditional agriculture. Most of the land is usar land. Land Use Due to the laterite condition of the soil, deficiency in rainfall, and no major rivers the land use pattern is different from the Gangetic plain. Some irrigated area takes into account of rabi, kharif and oilseeds crops. But generally it is best suited for vegetables, medicinal plants growing and floriculture due to natural drainage of water and no waterlogging conditions

As in other districts of Chhotanagpur, Koderma district too is endowed with mineral resources. In the district, minerals such as Mica, Limestone, Fire Clay, Feldspar, Metallic stone and other precious stone are found in good quantity, China Clay, Quartz are found. International Mica has been found in the district but with the advent of new forms of insulator Mica has lost its importance and the production of Mica stopped.

Overall Wind Rose Diagram of project area in winter months

The Predominant wind direction of project site during winter days is NW.

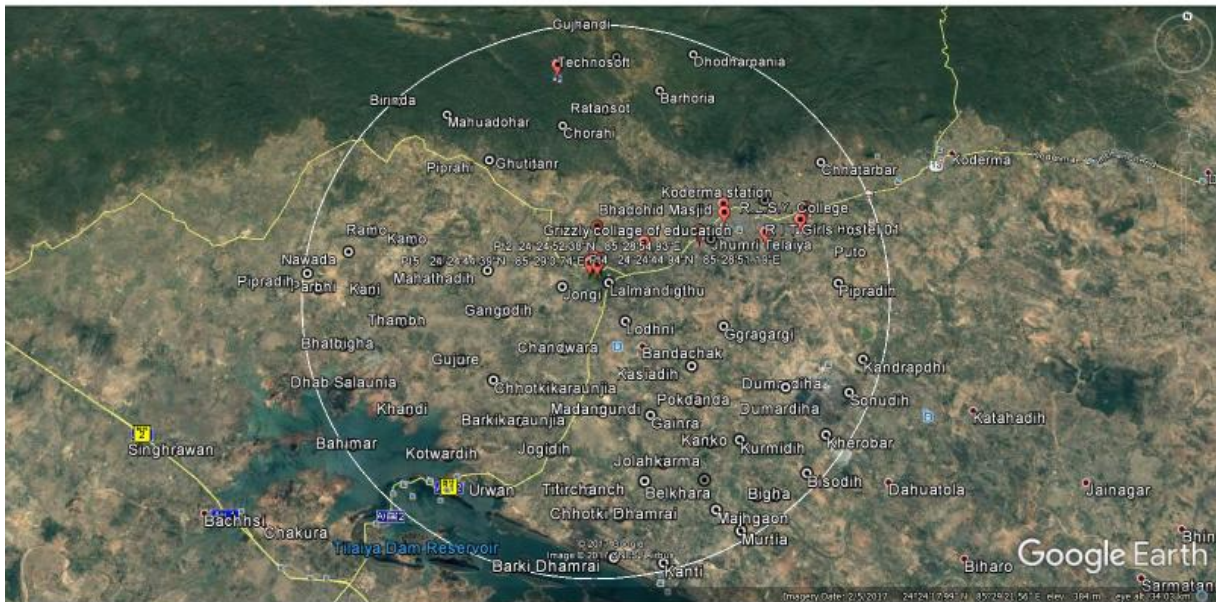
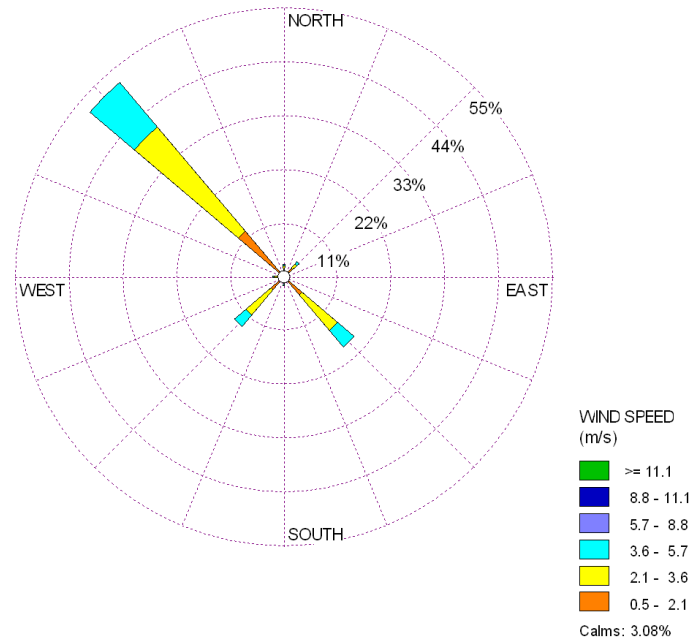

Places selected for AAQ sampling are:

- 1) Lodhini 1.8km SE
- 2) Gainra 4.5km SE
- 3) Chandwara 3.0km SSW(town high population)
- 4) Titirchanch 7.0km S

- | | | |
|---------------------|-------|-----------------------|
| 5) Chorni | 7.0km | NNE(near forest) |
| 6)RIT Girls' hostel | 5.0km | NEE |
| 7) Urwan | 8.0km | SW (near Taleiya dam) |
| 8) Inside Plant | | core zone |

Climatic data from secondary source

The climate of Koderma can be described as a transition between the dry and moderately extreme climate of the northern India and the warm, humid climate of Bengal Basin. The climatic year of Koderma district can be divided into four principal seasons.

Its climate is moderately hot and humid. The average rain fall is 1192 mm and the temperature ranges from 4°C in winter to 42°C in summer. The soil is mostly lateritic with the patches of clay soil. In lateritic soil the crop production is restricted to paddy whereas in the clay soil area wheat, potato, radish etc

Majority of the population is dependent upon agriculture. The average size of holding is very small land holding. In absence of adequate irrigation facility, farmers are dependent on monsoon rain for agriculture work. So they get employment in agriculture for part of the year and remain unemployed for rest of the year. Due to lateritic nature of soil average crop production is very low. Total area under forest is 53841 hectares. While Sal trees constitute the major forest plantation area, the other important trees are Simul, Palas, Mahua etc. Certain activities like picking kendua-patta, making of plates from sakhua leaves provide sustenance to the poor people.

Social infrastructure available

As per the 2011 census the total number of literates in Chandwara CD Block was 43,936 (63.75% of the population over 6 years) out of which males numbered 27,432 (76.82% of the male population over 6 years) and females numbered 16,504 (49.69% of the female population over 6 years). The gender disparity (the difference between female and male literacy rates) was 27.13%.

As per the 2011 census, literacy in Koderma district was 66.84%, up from 52.20% in 2001. Literacy in Jharkhand (for population over 7 years) was 66.41% in 2011. Literacy in India in 2011 was 74.04%.

The 79.7 km long first stage railway project from Koderma to Hazaribagh costing Rs. 936 crore was inaugurated by Prime Minister Narendra Modi on 20 February 2015. The railway line passes through this CD Block and there are stations at Pipradih and Urwan.

About 41% part of the Koderma district is covered with forests. The total forest area of Koderma district is 64796.90 hectare is scattered in 309 forest villages as protected

forest under administrative control of Koderma Forest Division together with 15062.77 hectare scattered in 35 forest villages as a reserved forest.

The per capita forest area in hectare is 0.14. Sal is the main forest crop together with Bija, Gamhar, Khair, Palash, Salai, Semal, Bair, Arjun, Karam, Siris, Kaj, Kend, Mahulan, Mahua, Karanj, Ratti etc. Koderma forest area having Barakar, Sakri, Dhadhar and Telaiya River are the main river of koderma forest. Koderma Forest division is rich in geological assets with biggest concentration of Mica in the Country. Archaen and the lower Gondwana are the two main rock formation found in this division. Due to several adepic and bioteic factors the forest of koderma division are very poor and in degraded and depilated coindition. They are badly affected by soil erosion and biotic interference. With the organisation of 309 Village Forest Management and protection committee, the forest density & canopy is increasing since recent years with the active participation of the members of concern forest committee. Social Forestry division is also functioning in this district

CHAPTER-5 PLANNING BRIEF

5.1 PLANNING CONCEPT

Planning (also called forethought) is the process of thinking about and organizing the activities required to achieve a desired goal. It involves the creation and maintenance of a plan,

The **planning** process (1) identifies the goals or objectives to be achieved, (2) formulates strategies to achieve them, (3) arranges or creates the means required, and (4) implements, directs, and monitors all steps in their proper sequence.

Planning is one of the most important project management and time management techniques. Planning is preparing a sequence of action steps to achieve some specific goal. If a person does it effectively, they can reduce much the necessary time and effort of achieving the goal. A plan is like a map. When following a plan, a person can see how much they have progressed towards their project goal and how far they are from their destination.

At each stage, the project is to be evaluated to know whether progress is as per the planning, short falls are to be reviewed and overcome. It is to be forecast which component is coming on critical path and unless it is completed as per the planning all other jobs will get delayed and time being money a serious loss will occur, which will increase the break even.

5.2 POPULATION PROJECTION

Direct employment has been estimated to be 300 including existing, with indirect employment and families taken into consideration population is projected to be 1,500 for whom market facilities, services, schooling for children, sports facility, places of worship are required to be developed.

The project has been proposed to be completed in three years of time, hence jobs are to be broken into segments and inter linked.

No colony has been proposed for the employees, most of the work men will be from locality.

5.3 LAND USE PLANNING

Land in possession is 9.24ha, on which existing DRI kilns are running and it has been planned to accommodate expansion DRI kilns, WHRBs and AFBC in the vacant space available on this land. Land use break up is as follows.

33% area of total land will be used towards development of green belt.

Sl.No	Facilities	Area in ha
1	Existing DRI Kilns	1.68
2	Proposed DRI Kilns	3.00
3	Raw material storage yard	0.85
4	Raw water storage pond	0.20
5	Solid waste storage area	0.26
6	Rain water harvesting pond	0.10
7	Green belt area	3.05
8	Vacant space	0.10
Total		9.24

5.4 ASSESSMENT OF INFRASTRUCTURE DEMAND

No such major infrastructure is proposed. The existing running unit is well connected with roads and communications, water and electricity connection which will be utilised for the expansion project. The captive power generation being more than internal consumption about 4MW power is to be sold to state grid for which infrastructure needs to be developed.

5.5 AMENITIES/FACILITIES

No additional facilities have been proposed except tie up with Govt./private hospitals for treatment of major cases.

Bath room, latrine and rest room facilities for lady workers is proposed.

CHAPTER-6 PROPOSED INFRASTRUCTURE

6.1 INDUSTRIAL AREA

Industrial area has developed infrastructure like internal roads, Electrical substation, water reservoir, solid waste and raw material storage yard, administrative building etc. which will be availed for expansion work.

For setting up two more DRI kilns, WHRB and AFBC, earth work, foundation and structural work has to be done without affecting running of existing plant.

6.2 RESIDENTIAL AREA

Majority of work force will be from locality only, hence no colony has been proposed. Hence supply of drinking water, electricity or MSW management has not been proposed.

6.3 GREEN BELT

Green belt exists for the existing project, it has to be strengthened further. Total land of 3.05ha, consisting of all around project boundary wall, side of internal roads, around Raw material and solid waste storage area will have trees for control of dust and sound pollution. Three tire local tree plantation will form a green belt around project area.

6.4 INDUSTRIAL WASTE MANAGEMENT

Industry will generate construction waste, excavation of top soil, solid and liquid waste generation during project operation.

Metallic scraps will be collected and send to Induction Furnace of sister unit at Giridih, top soil to be stored and used in green belt development.

Waste water generated from operation of DRI kilns are not contaminated, which will be cooled and reused. Waste water from AFBC to be settled, treated and recycled. No waste water will be discharged out of project boundary

6.5 SOLID WASTE MANAGEMENT

Solid waste	Quantity in TPA	Utilization Measures
Dolchar	30,720	To be burn in AFBC to produce steam for power generation
DRI Fly Ash	42,240	Supply free of cost to fly ash brick manufacturers
AFBC Fly Ash	15,200	Supply free of cost to fly ash brick

		manufacturers
AFBC Bottom Ash	10,000	Land filling, cement manufacturing as it contains lime in high percentage.

The Solid wastes will be treated as by products and these will be fully utilized.

6.6 POWER REQUIREMENT & SUPPLY/SOURCE

Power

Unit	Power requirement in MW
DRI Plant	2.0
Power Plant internal Consumption	1.8
Domestic use with lighting	0.2
Total	4.0

Own power generation will be 18 MW whereas Power consumption will be about 4MW, hence agreement to be made to supply balance power to Jharkhand state Power grid

CHAPTER-7 PROJECT SCHEDULE & COST ESTIMATE

7.1 PROJECT COST

The total Project cost of expansion project including preliminary cost, Pre-operative expenses and others is estimated to be about 190 crores, the break up is as follows.

Items	Cost in Crores
Site development	2.00
Cost of equipments	153.00
Pollution control equipments, 4 ESPs with ID fans & stacks	5.25
Mechanical & electrical equipment & cost of erection	7.00
Design, engineering & consultancy	2.75
Contingency	15.00
ESC activities	5.00
Total project cost	190.00

The project cost will be met from own contribution and bank loan.

7.2 PROJECT COMPLETION SCHEDULE

After getting CTE from SPCB, WB and EC from MOEF & CC tenders will be floated for purchase, installation and commissioning of equipment and units and earth work activities will start parallel. It is estimated the completion of project will take 18 months of time after getting prior Environmental Clearance.