

# **SJVN LTD**

(A Joint Venture of Govt. of India & Govt. of Himachal Pradesh)



## **SUNNI DAM PROJECT**

**(355 MW)**



### **CHAPTER ON**

### **GENERAL LAYOUT**

### **FOR 1ST CONSULTATION MEETING**

**(APRIL 2017)**



## CONTENTS

1.0 INTRODUCTION .....	2
1.1 Type of Project .....	2
1.2 Location of Project .....	2
1.3 Access to Project Area.....	2
2.0 NEED FOR THE PROJECT .....	3
3.0 ALTERNATIVE STUDIES FOR VARIOUS MAJOR COMPONENTS.....	3
4.0 ENVIRONMENT RELEASE .....	4
5.0 MAIN COMPONENTS OF THE PROJECT.....	4
5.1 River Diversion Works .....	4
5.2 Dam .....	4
5.3 Intake Structure.....	5
5.4 Pressure Shaft .....	5
5.5 Power House and Transformer Hall .....	5
5.6 Tail Race Tunnel and Outfall Structure.....	5
5.7 Access Tunnels .....	5
5.8 Main Access Tunnel .....	6
6.0 INTER STATE/INTERNATIONAL ASPECTS .....	6
7.0 COST AND BENEFITS OF SCHEME .....	6
8.0 CONSTRUCTION PERIOD.....	6
9.0 SALIENT FEATURES .....	7

## 1.0 INTRODUCTION

### 1.1 Type of Project

Sunni Dam Hydro Electric Project is a run of the river type development proposed to harness the hydel potential of river Satluj. The project envisages construction of a concrete gravity dam of  $\pm 95$  m high above deepest foundation level across river Satluj near Khaira village and underground power house on the right bank.

### 1.2 Location of Project

The project is situated on Satluj River near Khaira Village, in Shimla and Mandi Districts of Himachal Pradesh. The dam is located at Longitude  $77^{\circ}12'39''$ E and Latitude  $31^{\circ}14'53''$ N. On the upstream of the project lies the 412 MW Rampur HPS, which utilises water discharged from the further upstream 1500 MW Nathpa-Jhakri project. On the downstream of Sunni Dam Hydroelectric project lies the 800 MW Kol Dam HPS (FRL 642 m). In between Rampur HPS and proposed Sunni Dam Project, Luhri HEP Stage-I (nearly 50 km upstream) and Luhri HEP Stage-II (Between LHEP-I & Sunni Dam) are also proposed. L-Section showing all the projects is enclosed as *Annex-1*.



Fig. 1: Location map of Sunni Dam HEP.

### 1.3 Access to Project Area

The project site is located at about 155 km from the nearest railhead at Kalka in Haryana and can be approached by NH-5 followed by SH-13 and MDR-22 via Shimla, Naldhera and Chaba. The



nearest airport is at Jubbar Hati (Shimla) about 70 km from project site. The nearest international airport is located at Chandigarh at a distance of 160 km from the project site.

## 2.0 NEED FOR THE PROJECT

Himachal Pradesh is blessed with vast hydroelectric power potential in its five major rivers. Gurgling rivers and their tributaries with steep gradient continue to challenge planners and engineers for optimal exploitation of hydropower potential. Numbers of hydroelectric projects are under execution in the state by central, state, joint and private sector developers. The only strategy followed in Himachal Pradesh for exploitation of hydroelectric power resources is to produce as much energy as possible, as fast as possible, with minimum cost and with minimum environmental negative impacts. The speedy exploitation of hydroelectric power potential will definitely improve the economic health of the State because 12 percent free power plus 1% LADF on all new installations will increase the resources of the state to a significant extent. The need for the project also arises from the need to fulfil a steady increase in peak electricity demand and the growing energy deficit in the Northern Region.

## 3.0 ALTERNATIVE STUDIES FOR VARIOUS MAJOR COMPONENTS

The following alternative studies were carried out to explore the selection of Project layout:

- i) Alternative-1: Dam and surface toe Power House at left bank.
- ii) Alternative-2: Dam and underground power house at right bank

### **Alternative-1: Dam and surface toe Power House at left bank**

Since the slope of left bank is much gentle in comparative to right bank. A possibility of surface power house on left bank has been studied. It was observed that the power house site encompasses the nalla fans and sufficient space will be available after removal of the nalla material. But the study of catchment of nallas indicates that there will be potential danger of material flowing in the nalla and coming to the power house site. The power house will always be vulnerable from stability of slopes view point. Further, the sheared contact is lying on the downstream of dam axis with upstream dips when interpreted and projected to dam axis is likely to lie very close to assume foundation of dam. Therefore, Alternative-1 option is rejected.

### **Alternative-2: Dam and underground power house at right bank**

An option of dam  $\pm 400$ m upstream of Alternative-1 dam site with underground power house has been studied. The dam and power house are likely to be housed in quartzite and the same is adopted for further study. The General layout is shown in drawing attached as *Annex-2*.



**4.0 ENVIRONMENT RELEASE**

The environmental discharge that will be released from the dam as per MOEF guidelines and the same is given in table below. It is proposed that the environmental release is used to generate electricity in an appropriately sized turbines situated in toe-powerhouse.

**Environmental Releases as per MOEF guidelines**

Season	Environment Flows (in cumecs)	Mode of release of Environment Flows
Monsoon Period (June-Sep)	170.92 (30% of avg, Monsoon Flow)	Through 67.4 MW & 18 MW Machines
Non-Monsoon and Non-Lean Period (Oct-Nov.-April-May)	72.38 (25% of avg.NM-NL flow)	Through 67.4 MW Machine
Lean Period (Dec.-March)	21.09 (20% of avg. Lean flow)	Through 18 MW Unit Machine

**5.0 MAIN COMPONENTS OF THE PROJECT**

**5.1 River Diversion Works**

The diversion tunnel is expected to be constructed in left side of the river valley. 10.5 m dia, horse shoe shaped diversion tunnel is designed to pass diversion flood up to 780 m<sup>3</sup>/s. The height of upstream cofferdam shall be ±22.0 m and the height of downstream coffer dam shall be ±6.0 m.

**5.2 Dam**

A ±95m high, concrete gravity dam from deepest foundation level ±623m, with integral 6 nos. gated spillways having size of 8.5m (W) X 15.0m (H) have been proposed. . The spillway has been designed to pass design flood corresponding to Probable Maximum Flood of 15842 m<sup>3</sup>/sec. The Full Reservoir Level has been kept at 710.0 m and Minimum Draw Down Level at El. 707.0 m. The dam would provide a gross pondage of 73 MCM and live storage of 8.8MCM. The length of the dam at top shall be 185 m. The proposed dam is divided in 11 blocks as tabulated in Table below:

**Table 1: Details of Dam Blocks**

Sl. No.	Description	Total length (m)	No. of blocks	Block no.	Remarks
1.	NOF section on left bank	46	2	1 to 2	Total no. of Blocks = 11
2.	Over flow blocks	87	6	3 to 8	
3.	NOF section on right bank	52	3	9 to 11	



### 5.3 Intake Structure

Intake structure is proposed on right bank for diverting the design discharge of  $713.2 \text{ m}^3/\text{sec}$  from the reservoir to the underground power house. The centre line of intake shall be at  $\pm 694.0\text{m}$ . Trash screens will be provided to prevent coarse floating or submerged debris being drawn into the pressure shafts. Trash rack cleaning facilities should be provided. The trash screens are so planned that the passing velocities are below  $1.5 \text{ m/s}$  as mentioned in IS: 9761-1995- Hydropower Intakes- Criteria for Hydraulic Design.

Discharge from intake-1 and 2 ( $270.8 \text{ m}^3/\text{sec}$  each) shall be utilized for main units and discharge through intake-3 ( $171.6 \text{ m}^3/\text{sec}$ ) shall be utilized for environment units.

Intake gates with stoplog gates are provided to enable inspection and maintenance whilst the reservoir is impounded and to prevent heavily sedimented water depositing sediment within the pressure shaft entrance area during extreme floods.

### 5.4 Pressure Shaft

For flexibility of operation and maintenance, 3 nos. pressure shaft have been proposed which shall further bifurcated into six to pass total discharge of  $713.2 \text{ m}^3/\text{sec}$ .

### 5.5 Power House and Transformer Hall

Underground power house having with size of  $185.42 \text{ m (L)} \times 22.0 \text{ m (W)} \times 48.36 \text{ m (H)}$  shall be provided on right bank with installed capacity of  $355 \text{ MW}$  ( $4 \times 67.4 \text{ MW}$  – Main Units,  $1 \times 67.4 \text{ MW} + 1 \times 18 \text{ MW}$ - Environmental Units). The power house cavern is proposed  $\pm 200\text{m}$  inside the hill with as top cover of  $\pm 300\text{m}$ . Further, minimum  $50.0 \text{ m}$  rock cover is available between transformer hall and machine hall. The Preliminary Layout Plan Arrangement of Machine is attached as *Annex-3*.

### 5.6 Tail Race Tunnel and Outfall Structure

Water exiting from the turbines will be discharged through the draft tubes into the 2 nos.,  $9.8\text{m}$  dia horse shoe shaped tail race tunnel. The length of tail race tunnel shall be  $\pm 350.0\text{m}$ . The TRT outfall gated structure after TRT has been proposed with crest level of  $\text{El } 647.2 \text{ m}$  for discharging water from TRT to Satluj River.

### 5.7 Access Tunnels

The access tunnels to the machine hall and transformer hall have been proposed based on the size of the vehicles and equipment required to be transported through them, a maximum slope of 1 in 15 and making them as straight as possible for ease of manoeuvring large vehicles.



### 5.8 Main Access Tunnel

The main access tunnel will be approximately 700 m long with a maximum slope of 1 in 15. It is anticipated that an enlarged section will be created at the junction between the tunnel and the machine hall loading and erection bay to form a parking area.

### 6.0 INTER STATE/INTERNATIONAL ASPECTS

The project lies in Satluj basin, which is a part of Indus Basin, and is to be governed by relevant provision of Indus water Treaty signed between India and Pakistan in 1960. Since Satluj is an Eastern flowing river of Indus Basin, hence India has exclusive right over its water sharing.

### 7.0 COST AND BENEFITS OF SCHEME

The project is estimated to cost ₹ 2911.85 Cr. including IDC and financing charges at March, 2017 price level. The Annual energy of the project calculated as 1299 GWh. The breakdown of the cost estimates is given below:

Total Hard Cost at March'17:	₹ 2414.20 Crores
Interest during Construction:	₹ 487.46 Crores
Financial Charges	₹ 10.16 Crores
Total Basic Cost including IDC and FC:	₹ 2911.85 Crores

The tariffs for the project are as below:

1 <sup>st</sup> year Tariff	₹ 5.40/kWh
Levelised Tariff	₹ 5.07/kWh

### 8.0 CONSTRUCTION PERIOD

Sunni Dam Project is proposed to be completed in 5 years.



**9.0 SALIENT FEATURES**

<b>I) Location</b>	
State	Himachal Pradesh
District	Shimla & Mandi
River	Satluj
Nearest Village (Dam Site)	Khaira
Rail Head	Kalka (Haryana) 155km
Latitude of Dam Site	31°14'53"N.
Longitude of Dam site	77°12'39"E
<b>II) Hydrology</b>	
Catchment Area at Diversion Site	52955 km <sup>2</sup>
90% dependable year	2001-2002
Flood discharge for river diversion	780.00 m <sup>3</sup> /sec
Probable Maximum Flood (PMF)	15842.00 m <sup>3</sup> /sec
<b>III) Reservoir</b>	
Full Reservoir Level (FRL)	EL 710.00 m
Minimum Draw Down Level (MDDL)	EL 707.00 m
Gross Storage at FRL	73.0 X 10 <sup>6</sup> m <sup>3</sup>
Dead Storage at FRL	64.2 X 10 <sup>6</sup> m <sup>3</sup>
Live Storage at FRL	8.8 X 10 <sup>6</sup> m <sup>3</sup>
Length of Reservoir	18.00 km (approx.)
Desilting Basin	Reservoir will act as Desilting basin
<b>IV) Dam</b>	
Type of Dam	Concrete Gravity
Top of the Dam	EL 715.00 m
Average River Bed Level at Dam Site	EL 644.00 m
Dam Height above River bed	71.00 m
Length of Dam at Top	184.42 m
Top Width of Dam	8.00 m
Length of Overflow Blocks	87.00 m
Length of Non-Overflow Blocks	97.42 m
<b>V) Spillway</b>	
Design Flood (PMF)	15842.00 m <sup>3</sup> /sec
Type of Spillway	Combination of Upper Level Spillway(ULS) and Low Level Spillway(LLS) (sluice spillway)
Energy Dissipation System	Stilling Basin
<b>Low Level Spillway(LLS)(Under sluice Spillway)</b>	
Type	Sluice type



No. of Bays	Six(06) (Block No 3 to 8)
Size of opening	8.5 m (W) X 15.0m (H)
Type & No. of gate	Radial, Six (06)
Width of each block	14.5 m
Total width of LLS Blocks	87.00m
Crest Level	EL 660.00 m
<b>Upper Level Spillway(ULS) (Overflow Spillway)</b>	
Type	Ogee with open crest overflow
No of Bays	One(01) (Block No. 7)
Size	8.5m (W) X 3.0m (H)
Type and No of gates	Flap Gate, One(01)
Width of each block	14.5 m
Total width of ULS	14.5 m
Crest of ULS	EL 707.00 m
<b>VI) River Diversion</b>	
River Diversion Discharge (1 in 25 years)	780.00 m <sup>3</sup> /sec
Diversion Scheme	Through Diversion Tunnel(DT) and coffer dams
Location of Diversion Tunnel	Left Bank
No. of Tunnel	One(01)
Diameter and shape of DT	10.5 m, Horse Shoe Shape
Length of Tunnel	710 m
<b>VII) Power Intake</b>	
Number of Intake	Three (03)
Invert level	EL 690.0
Discharge Capacity of Intake 1 and 2 (for Main Units)	270.8 m <sup>3</sup> /sec(10% additional capacity)
Discharge Capacity of Intake 3 (for Environment Units)	171.6 m <sup>3</sup> /sec(10% additional capacity)
Size of Intake gate	5.7m(W)X8.0m(H)
<b>VIII) Pressure Shaft</b>	
Number of Pressure Shaft	Three (03) further bifurcated into six (06)
Design Discharge for Pressure Shaft-1 and 2 (for Main units)	271 m <sup>3</sup> /sec
Design Discharge for Pressure Shaft-3 (for Environment units)	173 m <sup>3</sup> /sec
Diameter of Penstock	7.5 m and 5.4m after bifurcation
Length of Penstock	± 250.0 m
<b>IX) Power House</b>	
Type	Underground



Location	Right Bank
Size of machine Hall	185.42 m (L) X 22 m(W) X 48.36 m(H)
Normal Tail Water Level	EL 651.20 m
Minimum Tail Water Level	EL 647.50 m
Gross Head	57.8 m
Rated Head	54.8 m
Turbine Type	Francis
No of Unit	Six (06)
Design Discharge	713.2 m <sup>3</sup> /sec
Installed Capacity ( Main units)	4*67.4MW
Installed Capacity (Auxillary units)	1*67.4MW + 1*18MW
Total Installed Capacity	355 MW
<b>X) Tail Race Tunnel</b>	
Number	Two (02)
Size of Tunnel	9.8m di, Horse Shoe Shaped
Length of Tunnel	350 m
<b>XI) Power Generation</b>	
Design Energy (Main Units)	925.46 GWh
Design Energy (Auxillary Units)	373.53 GWh
Annual Energy	1298.99 GWh
Annual Load Factor (Main Unit)	40.04%
Annual Load Factor (Environment Unit)	51.60 %
<b>XII) Estimated Cost</b>	
Total Hard Cost at March'17 Price Level	₹ 2414.20 crore
Interest During Construction	₹ 487.46 crore
Financial Charges	₹ 10.19 crore
Total Project Cost	₹ 2911.85 crore
<b>XIII) Financial Aspects</b>	
<b>1<sup>st</sup> year tariff</b> at Power House bus bars (including IDC) during 90% dependable year as per CERC guidelines	₹ 5.40 /kWh
<b>Levelised tariff</b> at Power House bus bars (including IDC) during 90% dependable year as per CERC guidelines	₹ 5.07 /kWh
<b>XIV) Construction Period</b>	
Total construction period	5 years



NOTE

1. ALL DIMENSIONS ARE IN MILLIMETER AND ELEVATIONS ARE IN METER UNLESS OTHERWISE SPECIFIED

**SCHEMATIC SKETCH SHOWING L-SECTION OF SATLUJ FROM LUHRI HEP STAGE-1 TO KOL DAM**

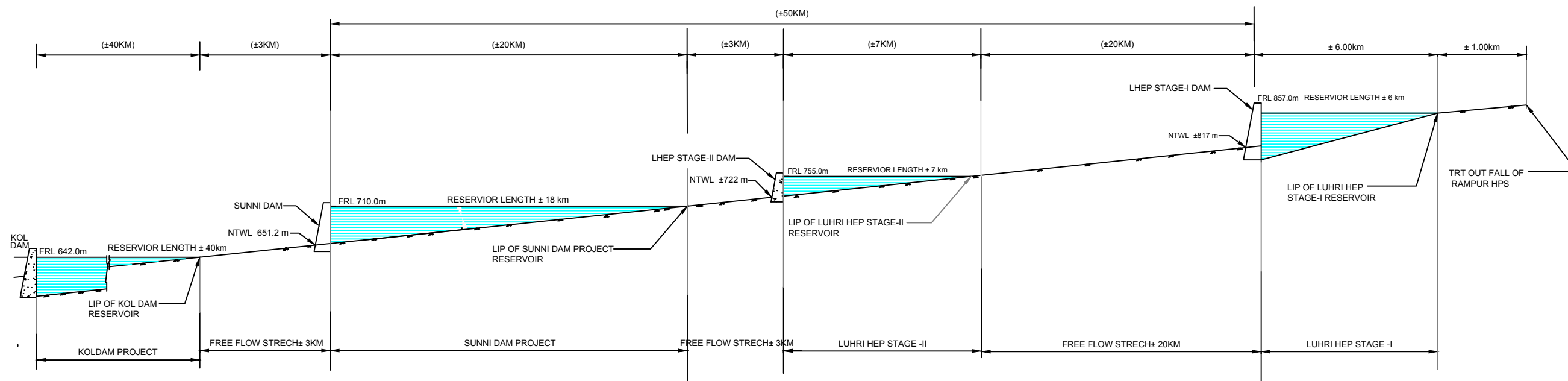

SUNNI DAM PROJECT	
FRL	710 m
NORMAL TWL	651.2 m
RESERVOIR LENGTH	±18 km

KOL DAM PROJECT (800MW) (UNDER OPERATION STAGE)	
FRL	642 m
NORMAL TWL	-
RESERVOIR LENGTH	±40 km

LUHRI HEP STAGE-II (Tentative) (SITE BEING FINALIZED IN CONSULTATION WITH GSI)	
FRL	755 m
NORMAL TWL	722 m

LHEP STAGE- I (210 MW) (UNDER DPR EXAMINATION)	
FRL	857 m
NORMAL TWL	817 m
RESERVOIR LENGTH	6 km

NOT TO BE SCALED

 एसजेवीएन लिमिटेड SJVN LIMITED		
लूहरी जल विद्युत परियोजना हि०प्र० SUNNI DAM PROJECT		
SCHEMATIC SKETCH SHOWING L-SECTION OF SATLUJ FROM LUHRI HEP STAGE-1 TO KOL DAM (CASCADE DEVELOPMENT)		
अभिकल्पित DSGN.	संशोधित CHKD.	संस्तुत RECM.
रेखांकित DRWN.	प्रस्तुत SUBM.	

NOTES:  
 1. THE LAYOUT AND NO. OF UNITS ARE TENTATIVE AT THIS STAGE, WHICH WILL BE FINALIZED AFTER FREEZING OF FRL AND HYDROLOGICAL STUDIES.



DAM AXIS CO-ORDINATES (PP')		
POINTS	EASTING	NORTHING
P	11832.294	32809.643
P'	11965.556	32682.158

DAM AXIS CO-ORDINATES (PP')		
POINTS	LONGITUDE	LATITUDE
P	77°12'34"	31°14'57"
P'	77°12'39"	31°14'53"

 <b>एसजेवीएन लिमिटेड</b> <b>SJVN LIMITED</b>		
<b>SUNNI DAM (H.P.)</b>		
<b>GENERAL LAYOUT PLAN</b>		
अभिकल्पित DSGN.	संश्लिष्ट CHKD.	संस्तुत RECM.
रेखांकित	परस्तुत	
SKETCH NO.		

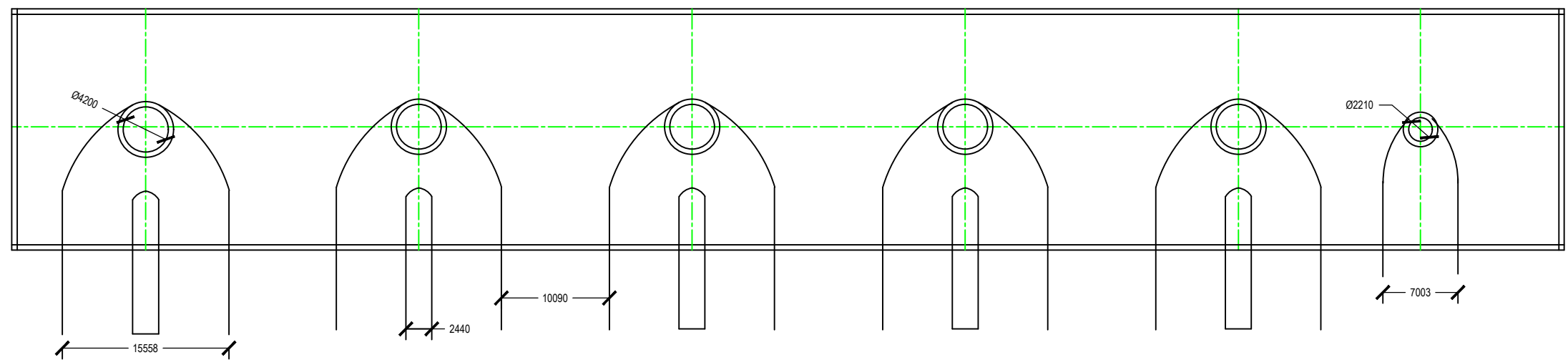
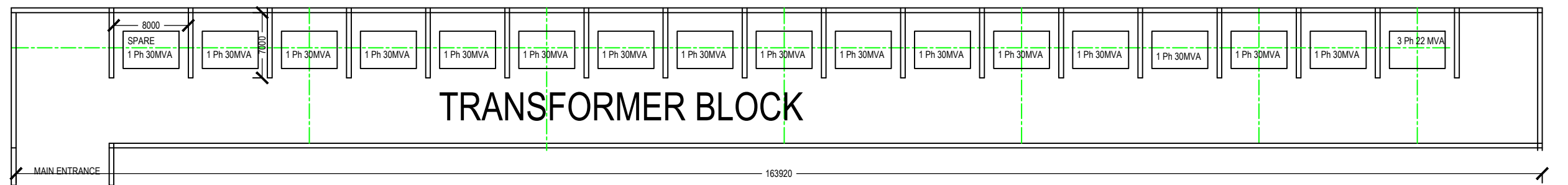
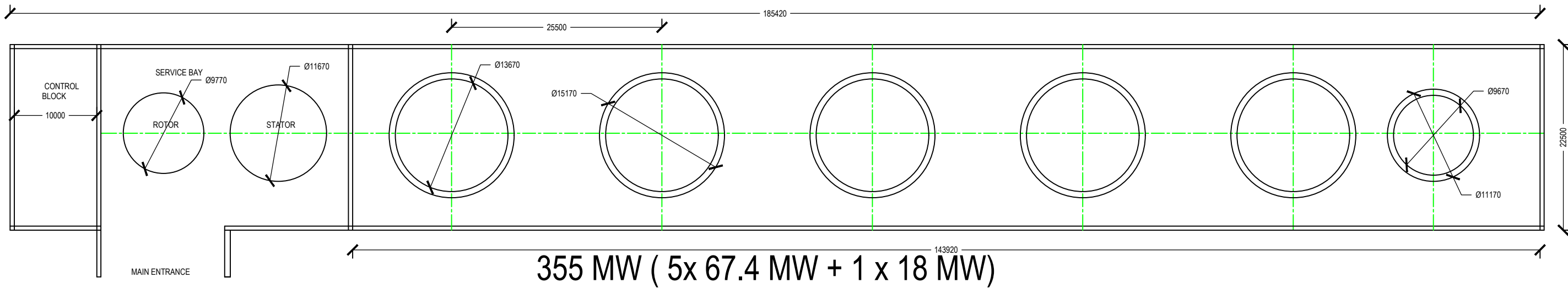

**SALIENT FEATURES (Tentative) :**

1. Plant Capacity - 355 MW
2. Unit rating as per above : 5x67.4 MW + 1x18 MW
3. Synchronous speed : 136 & 250 rpm
4. Over all dimension ( L x W x H ) 185.42m x 22m x 48.36 m

Note : The above arrangement has been made as per civil design letter no. 1090 dated 02.03.2017 & email dated 28.03.2017

<b>SJVN LIMITED</b>		
SUNNI DAM PROJECT 355 MW ( 5 X 67.4 + 1 X 18 )		
PRELIMINARY LAYOUT PLAN ARRANGEMENT		
DSGN.	CHKD.	RECM.
DRWN.	RECM.	APPD.
ELECT. DESIGN DEPTT. SJVN LTD.		
SCALE: NTS		

## 1. Introduction

Sunni Dam project is proposed on the River Satluj and falls in districts of Shimla and Mandi of Himachal Pradesh. The project is located in the inner lesser Himalaya between Dhauladhar range in the south and higher Himalaya in the north. The project envisages construction of a concrete gravity dam  $\pm 95\text{m}$  high from deepest foundation level across river Satluj near Khaira village on State Highway-22. Co-ordinates of the dam axis are E  $31^{\circ}14'53''$ , N  $77^{\circ}12'39''$ . The underground power house and its appurtenant structures ( $\pm 355\text{MW}$ ) are proposed on right bank.



**Photo 1: Showing location of various alternates for Sunni Dam Project.**

## 2. Accessibility:

The project site is located about 155 km from nearest rail head at Kalka in Haryana and can be approached by Kalka- Shimla – Sainj road road via. Basantpur, Sunni and Lunsu. The project is located at 15 Km milestone on Sunni-Sainj road.

## 3. Physiography and Geomorphology:

The project lies in the Inner Lesser Himalaya between the Dhauladhar range in the south and the Higher Himalayan Range in the north. The Satluj River is the main drainage in the

catchment area with headwaters located in the highlands of Tibet. Geomorphologically the area is located in a young mountain chain which is characterized by rapid down-cutting valley. Hence, most of the valley slopes are steep and the Satluj River is confined within narrow V-shaped valleys on the higher reaches. In the reaches u/s of the project flat land/terraces can be seen on the both on right & left river banks. The hill ranges in the right bank of Satluj river trend NW-SE and on the left bank NE-SW. The area forms part of the drainage basin of Satluj, which flows in nearly southwest direction. Behna khad, Kotlu khad, Gumma khad and Bahairari khad are important tributaries of the river Satluj. The drainage in the area exhibits sub-dendritic to trellis pattern controlled both by structure and lithology.

#### 4. Regional Geology:

The project area lies in Inner Lesser Himalayas SSW of main central thrust. The stratigraphy established in the Satluj Valley (after Sharma, 1977) is enumerated below in Table-1.:

**Table-1: Stratigraphy of Lesser Himalaya in Satluj Valley (after Sharma, 1977 and Unified Legend, GSI).**

Geological Age	Group	Formation	Lithology
Holocene		Newer Alluvium	Boulder, pebbles, coarse sand – younger terraces (T1) and river channel
Middle to Upper Pleistocene		Older Alluvium	Boulder, pebbles, coarse sand – older terraces (T2)
Palaeocene to Early Eocene	Sirmur	Subathu (Kakra)	Basal pisolitic laterite, quartz arenite, variegated shales and massive to thin bedded Limestone.
Mesoproterozoic to Neoproterozoic	Kullu	Khokhan	Quartzite, quartz chlorite and quartz biotite schist; slate, phyllite and schist, garnetiferous schist; locally associated with amphibolites.
		Gahr	Streaky mylonite gneiss, banded and augen gneisses
		Khamrada	Carbonaceous to graphitic schist and phyllite locally garnetiferous; lenticular grayish blue and cream coloured platy limestone and calcschist.
	Shimla		Quartzite-shale-limestone at the base, shale siltstone alternations with limestone interbeds; shale and siltstone alternations with ortho-quartzite and greywacke; greywacke sandstone, siltstone, shale alternation, orthoquartzite; quartzite, arkosic sandstone, protoquartzite, grey and purple shale at top
Palaeoproterozoic	Rampur		Quartzite with penecontemporaneous mafic meta-volcanics intruded by Bandal Granitoid Gneiss.
	Shali/ Larji	Bandla	Green and purple shale/ slate, siltstone sporadic limestone, thinly bedded

			orthoquartzite, interbeds green brecciated rock and a fairly persistent band of white quartzite at the base.
		Parnali	Cherty dolomite, grey limestone and white quartz-arenite
		Makri	Grey, green, black and purple shale and slate, thin bedded limestone, thin bedded quartzarenite with or without dolomite.
		Tattapani	Cherty dolomite, grey and pink colour with grey phyllitised shale.
		Sorghwari	Pink and grey cream textured limestone with shale parting
		<b>Khatpul</b>	<b>Massive dolomite with sporadic quartz arenite and a thin red shale band at the base</b>
		<b>Khaira</b>	<b>Mainly pink and purple, white quartz arena</b>
		Ropri	Brick red shale and siltstone with grey dolomite in the lower horizon; local development of salt, salt grit and the marly litho complex "Lokhan"
	Sundernagar Group		Quartzite with penecontemporaneous mafic volcanics (Mandi – Darla Volcanic), grey slate, phyllite, shale, limestone
Archaean	Jeori – Wangtu Granitoid		Augen gneiss, mylonitic gneiss, porphyroblastic biotite gneiss with intercalated biotite-garnet-kyanite-sillimanite-schist bands intruded by porphyritic and tourmaline granite, pegmatite and aplite

The project area lies in Khaira Formation and Khatpul Formation of Shali/Larji Group of rocks.

#### 4.1 Tectonics:

Four distinct patterns of folding are identifiable in the vicinity of the project area. Chamba Syncline and Rampur Anticline are main structure features whereas Main Central Thrust and Jutogh Thrust are major thrusts in the far upstream. The nearest structural feature being Kotlu thrust is  $\pm 20$  km u/s of the project. Magan anticline which is also known as Shali anticline is in the vicinity of the project area.

### 5. Geology of the Dam and Power House:

#### 5.1 Dam site

On the basis of reconnaissance survey and geological mapping of the designated area, various alternatives were studied stretching from downstream of Jaishi village (situated on left bank) to Marola village (situated on right bank) in an area of 3 km length along the river. All possible locations in this stretch were studied from geological view point. On the basis of various traverses taken by SJVN Geologist & Design Team and joint visit with Geological Survey of India, Chandigarh, two alternates were identified which have been

designated as first alternate as A-A' and second alternate as P-P'. The details of the study and conclusion are given below:

### **Alternate-1 (A-A'):**

This alternate was studied for its suitability from geological and construction point of view and its location is marked as A-A' on the geological plan (Plate-01). The dam axis A-A' is aligned N45°W – S45°E. The left abutment slope appears to be quite steep and lies between two nallas whereas right abutment slope is moderately steep (Photo-1). The proposed dam encompasses thinly bedded pink to purple quartzite of Khaira Formation whereas dolomite/limestone exposed just d/s of the dam axis is of Khatpul Formation belonging to Shali group. The power house is proposed on the left bank ±150m d/s of dam axis where sufficient space appeared to be available due to nalla fan. Khaira quartzite and d/s dolomite have sheared contact exposed 20m downstream on the left bank side and 90m downstream on right bank side of proposed dam axis A-A' at EL. 650m. The sheared contact is sub-parallel to bedding and strikes 100°-280° with dip amount of 55° in NE direction. Right and left bank at the proposed dam axis are represented by quartzite which is exposed up to approximately EL.700m at right bank and EL. 710m on left bank of the river.

The sheared contact lying on the D/S of the proposed Dam axis with u/s dips when interpreted & projected to dam axis is likely to lie very close to the assumed foundation of the dam. Part of the one of the abutments may also lie in the dolomite/limestone.

Further to study the proposed location in detail, a traverse along the right abutment has been taken along a path at el. ±740m (TOD-715m). It has been observed that geologically the right bank appears to be okay upstream also but the left bank u/s is dissected by nallas with small nalla fans at the bottom and the nallas being occupied by slide debris which render left side holes unsuitable for dam in general.

The proposed surface power house site suggested ±150m d/s from dam axis (on the left bank) was also inspected from the right bank. It was observed that the proposed power house site encompasses the nalla fans with space but the study of catchment of the nallas indicates that there will be potential danger of material flowing in the nalla and coming to the power house site. The power house will always be vulnerable from stability of slopes view point. Moreover the nalla being very prominent and old, the availability of the rock at desired depths for founding the power house was also doubtful.

Because of the above constraints the location A-A' of dam axis and that of surface power house as a whole appears unsuitable. Therefore further studies for this alternate were not perused.

### **Alternate-2 (P-P'):**

Traverse taken further u/s upto  $\pm 500\text{m}$  along the right banks from alternate A-A' indicated that the river valley from 100m to 500m continued to be narrow and have steep slopes. The slopes on both the banks are occupied by competent pink quartzite of Khaira Formation. The rock on the right bank and left bank is intersected by 3 sets of joints including foliation suitability oriented.

Prima-facie the abutment conditions  $\pm 400\text{m}$  u/s from alternate A-A' appeared good for abutting the dam (P-P') but at this location sufficient space will not available on both the bank for surface dam toe powerhouse. To develop space for surface power house lot of cutting of slope is required. To avoid this, underground power house complex was proposed on the right bank.

Keeping above in mind, the dam and power house site at alternate P-P' has been mapped by GSI & SJVN team on 1:2500 scale covering up to  $\pm 700\text{m}$  downstream of the dam axis and around 450m upstream from the dam axis. The geological map and section along dam axis are appended as Plate-01 and Plate-02 respectively. Geological section along longer axis of power house is appended as Plate-03.

The proposed  $\pm 95\text{m}$  high dam (P-P') is located  $\pm 450\text{m}$  u/s of alternate A-A'. This site is around 1 km u/s of the Khaira village (situated on the left bank of Satluj). The river Satluj at the dam site flows from NE to SW direction at approximately 645 MBD (meters above datum). The valley at dam site is narrow with moderate to steep slopes. Rock exposed on both the abutments is quartzite belonging to Khaira formation while dolomite/limestone belonging to Khatpul Formation of Shali group is exposed about 530 m downstream and  $\pm 300\text{m}$  upstream of the proposed dam axis on both the banks. While the right abutment has quartzite rock exposures throughout the slopes on the left bank upto the road level i.e.  $\pm 740\text{m}$ . The quartzite rock is overlain by thin overburden above that the thickness of overburden increases. The true width of the quartzite lithounit is about 800m which is sufficient to place dam and power house complex. On the right bank at the dam site, there is protruded rock ledge and the dam axis is placed on the d/s end of this protrusion. The dam axis is aligned  $N46^{\circ}W-S46^{\circ}E$ . The competent pink quartzite of Khaira Formation in general is dipping towards N to NE direction with  $20^{\circ}-60^{\circ}$  amount (Dipping u/s into the hill) with additional two to three set of joints (Table-2). The

contacts of dolomite/limestone and quartzite at d/s and u/s of dam axis are sheared and aligned sub-parallel to the bedding. These sheared contacts are 1.5m to 2.5 m thick and mainly consist of sheared rock with gauge along with cubic shape carbonate rich material. The local folding in the Khaira quartzite is also recorded on the right and left bank of dam area. As the bedding is dipping in upstream direction it seems to be favorable for dam. The details of joints are shown in Table 2.

**TABLE 2: Details of joints in the dam area.**

Set No.	Strike	Dip :Direction	Type	River bank
J1	E-W	20°-30°: N-N15°E	Bedding	Left
J2	S20°W –N20°E to S40°W-N40°E	75-85:N50°-70°W	Joint	
J3	N-S	55°-60°:E	Joint (open)	
J4	N30°-35°E- S30-35W	70°-80°:S60°-65°E	Joint	
J1	E-W	20°-60°:N	Bedding	Right
J2	N35°W – S25°E to N50°W-S50°E	70°-75°:S35°-60°W	Joint	
J3	N-S	55°-60°:E	Joint (open)	
J4	N70°E-S70°W	80:S20°E	Joint	

The study of the dam area indicate that the location of the dam is suitable from geotechnical view point

## 5.2 Power House Site:

The power house complex area comprising of PH cavern, TH cavern TRT & their approach tunnels are placed on the right bank & is occupied by Khaira quartzite with thin cover of debris. The power house components have been placed keeping in view the u/s and d/s contacts of quartzite with dolomite/limestone. The power house cavern is proposed ±200m inside the hill with a top cover of ±300m. The quartzite is quite competent in nature as in dam and has same set of joints continuing to the power house area. The bedding joint/foliation joints in general dip towards N to N10°E direction with amount varying from 20°-60°. Local folding and warping is seen in the area. The power house and transformer hall cavern are proposed to be aligned N20°E-S20°W direction. Considering the general strike of foliation/bedding joints as E-W to N70°W-S70°E, both the caverns are favorably aligned with intersection angle of alignment of cavities and that of Foliation ranging from 70°-90°. Other structures like TRT, MAT & adit to PH cavern are also suitably aligned vis-à-vis orientation of foliation joint except the last part of MAT and, approach tunnel to Transformer Hall.

The above locations of dam axis and Power House complex have been visited by Director GSI Chandigarh also.

## **6. Proposed Investigations:**

The proposed investigations comprising of 2533m of exploratory drilling, 760m of exploratory drifting, rock mechanic lab and in-situ studies, petrography, construction material survey, slope stability study and reservoir competency study are planned to be carried out in pre-DPR and DPR phases of the project. The detailed proposed investigation programme is appended as Annexure-1.

## **7. Reservoir Area:**

Due to proposed  $\pm 95$ m high dam, a reservoir  $\pm 20$ Km in length will be created. A traverse taken along the reservoir on the left bank along the state Highway indicates that the reservoir is occupied by Khaira quartzite on the lower levels and dolomite/limestone of Khatpul Formation on the higher levels. No major structural feature and no major slides are noticed in the Reservoir area. Reservoir area proposed to be mapped for Reservoir Rim Stability and Reservoir Competency.

## **8. Seismicity**

Himachal Pradesh falls in the Himalayan region, which is one of the more seismically active regions in the world. The Project area lies in the Shimla Block of the Main Himalayan Seismic Zone domain of NW Himalayan seismic belt (Narula et al. (2000) the project falls in Earthquake Zone V in accordance with the Seismic Map of India (IS:1893:1984). It is demarcated by the Main Central Thrust in the north and the Main Boundary Fault/Thrust (MBF/MBT) in the south, and limited in east and west by interpretative fundamental transverse faults. The Kangra Block lies to its west and the Garhwal Block in the east (Figure-1).



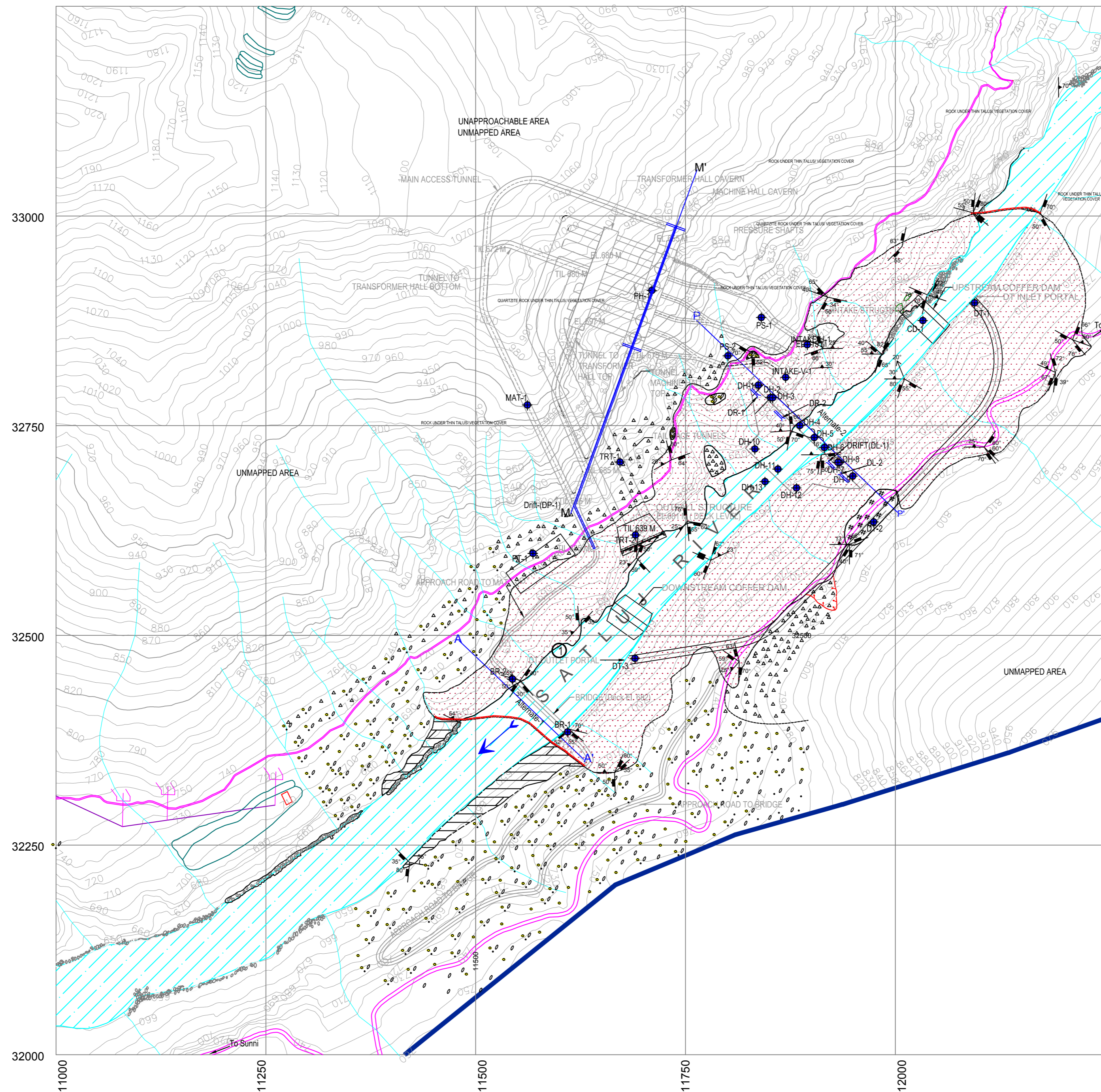
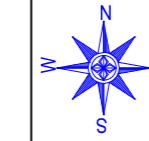

**INDEX**

	TALUS
	RIVER BORNE MATERIAL
	STONES (BOULDERS)
	DOLOMITE/LIMESTONE
	PINK/PURPLISH QUARTZITE
	FOLIATION JOINT PLANE SHOWING DIP AMOUNT & DIRECTION
	JOINT PLANE SHOWING DIP AMOUNT & DIRECTION
	LITHOLOGICAL CONTACT
	SLIDE
	PROPOSED DRILL HOLE
	PROPOSED EXPLORATORY DRIFT ALONG CROSS CUTS
	BOULDERS
	SLUMPED ROCK MASS
	SHEARED LITHOCONTACT
	DISTRICT HIGHWAY
	FOOT PATH

- REMARKS:**
1. The geological mapping of the area was carried out by team of Geologists from GSI and SJVN and the finalization is in progress.
  2. The power house hill is inaccessible at this moment. The approach paths to the power house hill are under construction.
  3. Prima-facie the area of power house hill seems to be cover with thin layer of talus and scanty vegetation with competent quartzite beneath.
  4. The geological data collected along the foot path on the right bank at El ±740m has been projected and used to develop the geological section along longer axis of power house.
  5. Contour plan is based on the LiDAR Survey carried out for earlier scheme (with HRT).

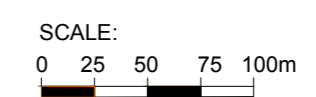

<b>SJVN Limited</b>		
<b>SUNNI HYDRO ELECTRIC PROJECT</b>		
<b>PROGRESSIVE GEOLOGICAL MAP OF DAM &amp; PH AREA OF SUNNI DAM PROJECT.</b>		
Prepared/Mapped By Parveen kumar Sr. Geologist (GSI) Mahesh Dutt Sr. Geologist (SJVN) Kuldeep Sharma Geologist (LHEP/SJVN)	Checked By K.S.Chauhan Akshay Acharya Sr.Manager(Geology)	Submitted to A.K. Chadha GM(Geology)
DRG NO: SJVN/GEO/SUNNI DAM/2017/01-Rev-00		Dated 28-03-17

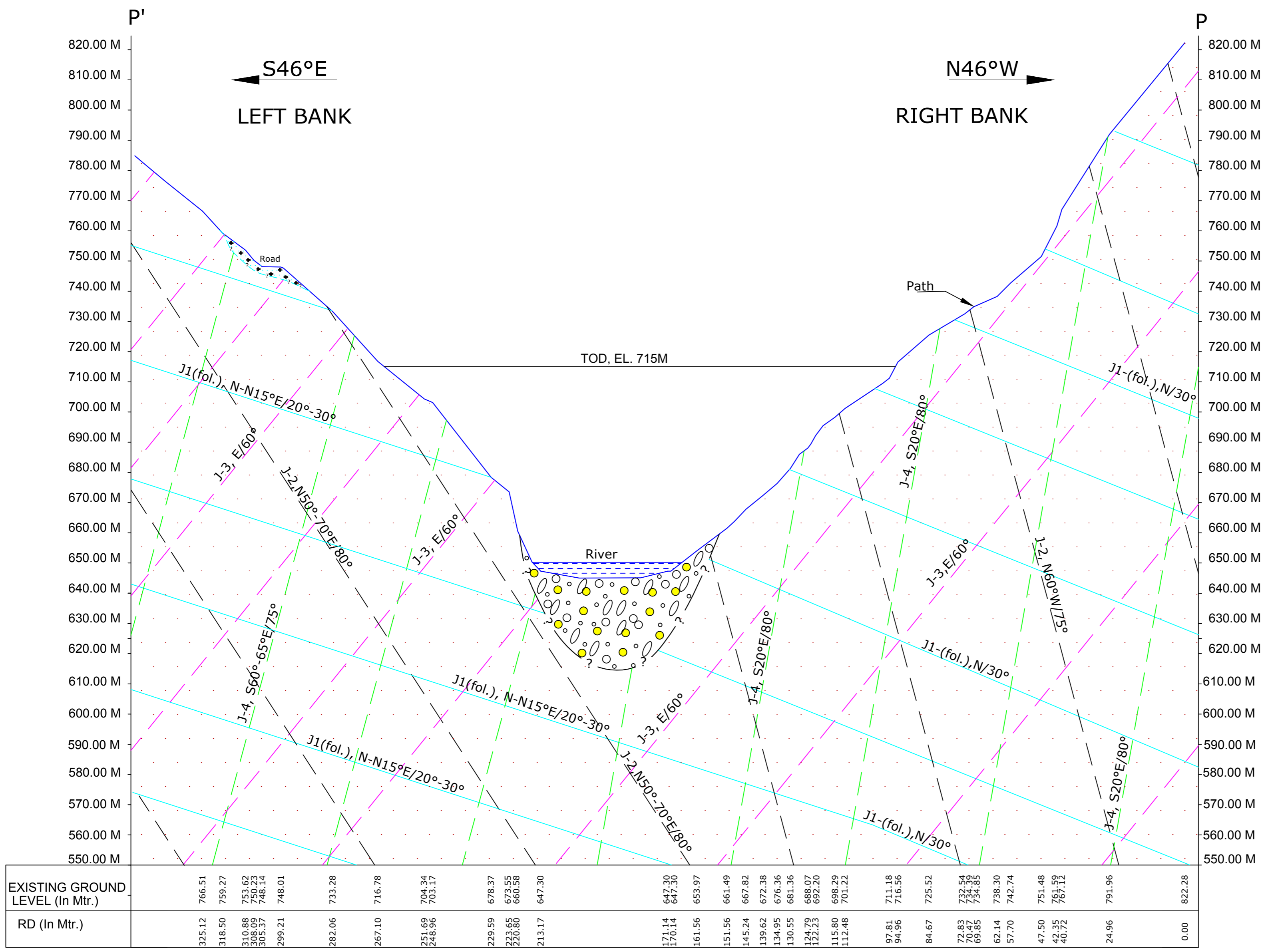

EXISTING GROUND LEVEL (In Mtr.)	766.51	759.27	753.62	750.23	748.14	748.01	733.28	716.78	704.34	703.17	678.37	673.55	660.58	647.30	647.30	647.30	653.97	661.49	667.82	672.38	676.36	681.36	688.07	692.20	698.29	701.22	711.18	716.56	725.52	732.54	734.36	734.85	738.30	742.74	751.48	761.59	767.12	791.96	822.28
RD (In Mtr.)	325.12	318.50	310.88	308.09	305.37	299.21	282.06	267.10	251.69	248.96	229.59	223.65	220.80	213.17	171.14	170.14	161.56	151.56	145.24	139.62	134.95	130.55	124.79	122.23	115.80	112.48	97.81	94.96	84.67	72.83	70.47	69.85	62.14	57.70	47.50	42.35	40.72	24.96	0.00

**INDEX**

- River Borne Material
- Quartzite
- Slumped Quartzite
- Joint Trace

**Prominent Joint Set of Right Bank**

Foliation/Joint Set	Dip Direction	Dip Amount
J1(Fol.)	N	30°
J2	N60°W	75°
J3	E	60°
J4	S20°E	80°

**Prominent Joint Set of Left Bank**

Foliation/Joint Set	Dip Direction	Dip Amount
J1 (Fol.)	N-N15°E	30°
J2	N50°-70°E	78°
J3	E	60°
J4	S60°-65°E	75°

- NOTE**
- The geological section(P-P') is based on progressive geological mapping carried out at dam site area. Refer drg. No. SJVN/GEO/SUNNI DAM/2017/01-Rev-00
  - The foliation/joints and their spacing depicted in the section are schematic.
  - True attitude of discontinuity is shown along the traces and apparent dips are plotted.
  - The depth of RBM in the river bed is based on the previous holes done at LHEP-Stag-1 and may be updated after actual drilling.

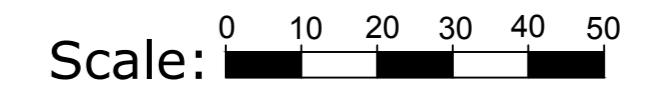

**SJVN LIMITED**

**SUNNI DAM PROJECT**

**GEOLOGICAL SECTION ALONG DAM AXIS (P-P') - SUNNI H.E.P, (H.P)**

Prepared by Mahesh Dutt Sr. Geologist Dharmendra kr. Giri Geologist	Checked by K.S. Chauhan Sr. Manager (Geo)	Recm. A.K.Chadha GM (Geology)
---	---	-------------------------------------

DRG No. : SJVN/GEO/SUNNI DAM/2017/01-Rev-01

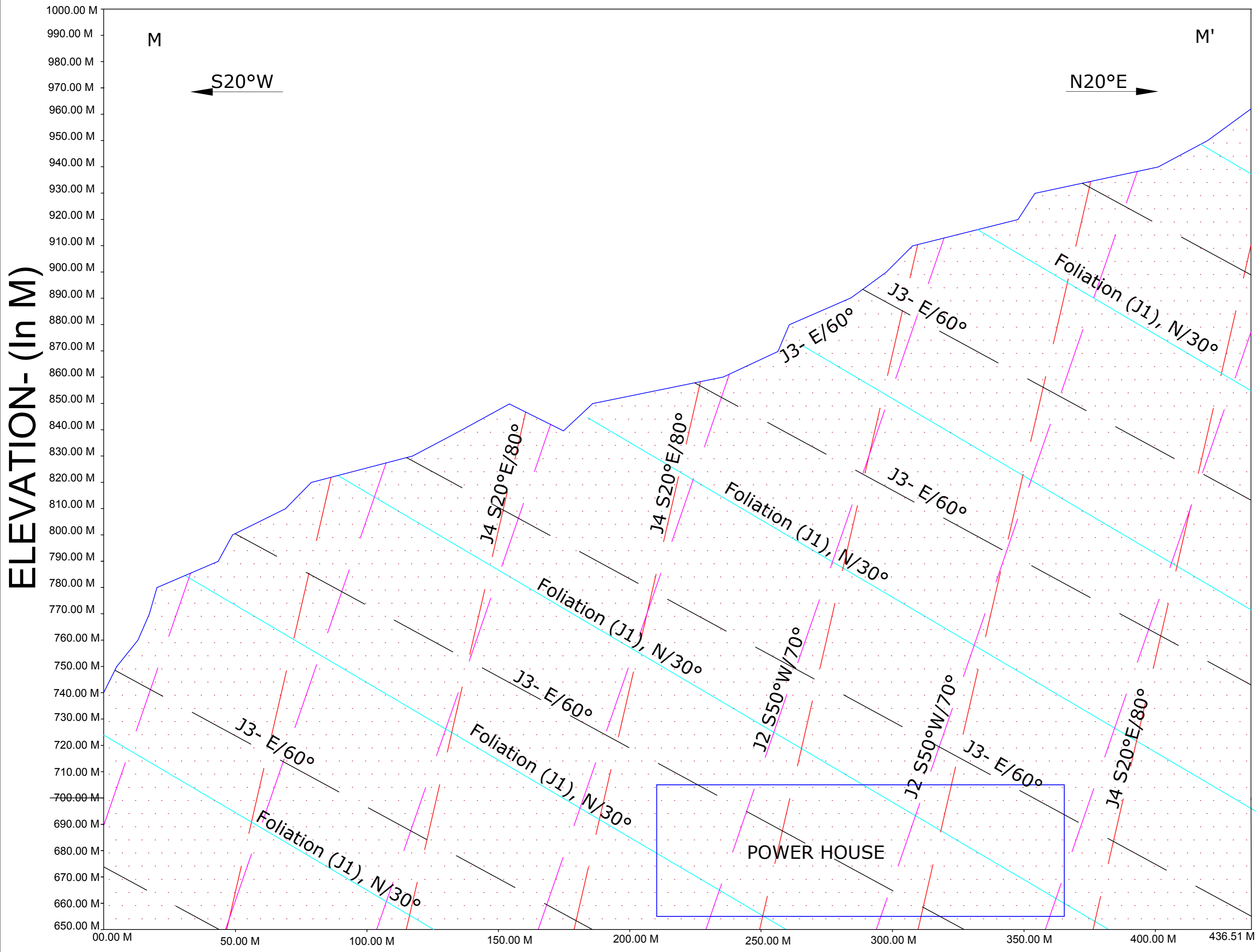

**INDEX**

	Pink/Purplish Quartzite
	Measured Sheared contact
	Joint Trace

**Prominent Joint Sets**

Foliation/Joint Set	Dip Direction	Dip Amount
Foliation (J1)	N	30°
J2	S35°-50°W	70°-75°
J3	E	60°
J4	S20°E	80°

- NOTE**
1. The geological section(M-M') is based on progressive geological mapping carried out at dam site area. Refer drg. No. SJVN/GEO/SUNNI DAM/2017/01-Rev-00
  2. The foliation/joints and their spacing depicted in the section are schematic.
  3. True attitude of discontinuity is shown along the traces and apparent dips are plotted
  4. The power house hill is inaccessible at this moment. The approach paths to the power house hill are under construction.
  5. Prima-facie the area of power house hill seems to be cover with thin layer of talus and scanty vegetation with competent quartzite beneath.
  6. The geological data collected along the foot path on the right bank at EI ±740m has been projected and used to develop the geological section along longer axis of power house.

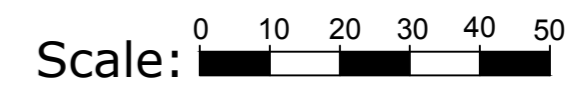

<b>SJVN LIMITED</b>		
<b>SUNNI DAM PROJECT</b>		
<b>GEOLOGICAL SECTION ALONG LONGER AXIS OF PH (M-M') - SUNNI H.E.P., (H.P)</b>		
Prepared by Mahesh Dutt Sr. Geologist Dharmendra kr. Giri Geologist	Checked by K.S. Chauhan Sr. Manager (Geo)	Recm. A.K.Chadha GM (Geology)
DRG No. : SJVN/GEO/SUNNI PH/2017/03-Rev-00		