

CHECK LIST OF ENVIRONMENTAL IMPACTS

SECTION 1- LAND ENVIRONMENT

(Attach panoramic view of the project site and the vicinity)

1.1 Will the existing land use get significantly altered from the project that is consistent with the surroundings? (Land use must conform to the approved Master Plan/Development Plan of the area. Change of land use, if any and the statutory approval from the competent authority are submitted). Attach Maps of (i) site location, (ii) surrounding features of the site (within 500 meters) and (iii) the site (indicating levels & contours) to appropriate scales. If not available attach only conceptual plans.

➤ **No**

The project site is vacant land. It is anticipated that the construction activities of the project will not have an adverse effect on the land use activities in the project area. Government of India has announced the Super Corridor to be developed in Indore city along with the amenities to be developed on both sides of the corridor. The development of green belt and other landscaping will enhance the visual aesthetics of the area.

The Project site is linked with the MR-10 (L= 4 km) and the RW-2 (L= 8.5 km), which are bound for Indore Airport from Sukhliya area. Indore and Bhopal are well connected by railway which is passing through the lower part of MR-10. In order to connect between existing industrial complexes and small villages, there are 10 slip roads in the area between MR-10 and SH-27.

1.2 List out all the major project requirements in terms of the land area, built up area, water consumption, power requirement, connectivity, community facilities, parking needs etc.

➤ **LAND REQUIREMENT**

Table 1: Area Statement

ITEM		SCHEME 151
TOTAL AREA		3557900
AREA LAND TRANSFERRED TO GOVT.		411400
A.	TCS	315400
B.	INFOSYS	96,000
AREA UNDER AABADI		127,000
AREA UNDER Railway land		11,900
Area UNDER GAIL land		7,200
AREA UNDER GRAVE YARD (existing)		11100
SUB-TOTAL		568600
Net Remaining area for planning in scheme		2989300
AREA UNDER Sector A		894600
AREA UNDER RAILWAY STATION		6,600
Area under 75.0 m (RW-2) + 5 m wide green belt both side(Existing)		527400
Area under recreational use as per IDP 2021 (stadium)		73300
SUB-TOTAL		1501900
NET PLANNING AREA		1487400
COMMERICAL		976900
AREA Coordinated Plotted Area		100
PUBLIC FACILITIES		3450
Green area (17.69 % of Net Plot area)		263100
PARKING		34433
ROAD		155401
PEDESTRIAN		47743
Other Commercial Facilities(PETROL PUMP, Etc)		1600
SW Transfer Station		1,192
UTILITY		1,807
Communication Node		104
M.P.E.B. GRIDE		1,570

Table 2: Built-up area calculation

Item	Area(m²)	FAR	Built-Up Area
NET PLANNING AREA OF SCHEME 151	1487400		2936050
• Commercial	976900	3.0	2930700
• Public Facilities	3450	1.0	3450
• AREA Coordinated Plotted Area	100	3.0	300
Other Commercial Facilities(PETROL PUMP, Etc)	1600	1	1600
M.P.E.B. GRIDE	1,570		
Etc (Park, Parking, Road, Pathway)	500677		

FAR*: Floor Area Ratio

➤ **WATER REQUIREMENT**

The water supply will be provided through the Indore Development Authority. The total water requirement is approx. 12678 KLD, out of which total domestic water requirement is 10294 KLD. The potable water requirement is approx. 6168 KLD which is 70% of the domestic water demand for residential and 30% of the domestic water for commercial population.

➤ **POWER REQUIREMENT**

- As per the load forecast for Super corridor, the connected load is expected as 38245 KVA approximately.
- The predicted demand is 38245 KVA approximately. For feeding this load at least one 220/132 KV EHV substation is required. Even if one 220/132KV substation has installed capacity of above 38245, another EHV substation is recommended to be installed near east end of Super Corridor. The reason for two EHV substations is as follows:
 - Alternate source is necessary for redundancy.
 - This will facilitate feeding from two ends resulting in reduction in feeder lengths.
 - Due to reduction in feeder length losses will be less.

- There will be less number of loads on each feeder. Hence system will be more reliable.
- As per discussion with the authorities of power distribution company (MPPKVV Co. Ltd.) and transmission company (MPPTRANS Co. Ltd.), one 2x160MVA, 220/132/33KV EHV substation will be established by MPPTRANS Co. Ltd. at Village Chota Bangarda near west end of Super Corridor. For this land will be provided by Indore Development Authority (IDA).
- The 33KV out going feeders through underground cables will be used to evacuate power from the EHV substations. The 33KV power distribution will be in ring main system. The maximum length of each ring feeder will be about six to seven kilometer. Enclosed metal clad VCB type of Ring Main Units (RMUs) will be installed to tap power for each plot.
- For the areas where plot sizes are small 33/11KV substations will be established. In 11 KV distribution system also underground cabling will be done with Ring Main system. In 11 KV system the maximum ring main feeder length will be two to three Km.
- For distribution of power to end users and for street lighting/ public area lighting 11/0.4 KV distribution substations will be established in the premises of plots or at ends of open areas (for street/public area lighting). Radial underground Low Tension (LT) feeders will be used to supply power to end users through system of LT Feeder Pillars. The maximum length of LT feeders will not exceed 0.3 to 0.4 Km. The length of service line cables will be restricted to 40-50 mtrs.

Details of D.G Sets

1. The DG sets will be installed by the individuals purchasing the plot (Residential /Commercial) from Indore Development Authority. The back up DG sets in these individual plots will be installed as per their work requirements & electricity load requirement. The DG sets will be equipped with acoustic enclosure to minimize noise generation and adequate stack height for proper dispersion.
2. For public lighting, 30 percent street lights on major junctions will be will provided solar power back up, as proposed.

➤ **CONNECTIVITY**

The Super Corridor is linked with the MR-10 (L= 4 km) and the RW-2 (L= 8.5 km), which are bound for Indore Airport from Sukhliya area. Indore and Bhopal are well connected by railway which is passing through the lower part of MR-10. In order to connect between existing industrial complexes and small villages, there are 10 slip roads in the area between MR-10 and SH-27.

Near the junction of MR-10 and RW-2, there are small existing villages and SH-27 (W= 75 m) which is connecting to Indore and Ujjain. The nearest railway station is Indore railway station, about 4.5 km away from the project site. The nearest airport is Devi Ahilaya Bai Holkar International Airport, at 7.4 km from the project site.

➤ **PARKING FACILITIES**

As this is the plotted project Area development of Scheme 151(Sec B, C and D), Super Corridor developed by Indore Development Authority, the respective plots (Commercial/Residential) will be built up by the respective owner/developer of the plot. Therefore, the development of each of these plots by individual will be undertaken as per the state bye laws, under the supervision of experts. Adequate provision will be made for car/vehicle parking at each proposed project plot. There shall also be adequate parking provisions for visitors so as not to disturb the traffic and allow smooth movement along the corridor & in the nearby areas.

1.3 What are the likely impacts of the activity on the existing facilities adjacent to the site? (Such as open spaces, community facilities, details of the existing land use and disturbance to the local ecology).

Total green area measures **263100 m² i.e. 17.69 %** of the total area which will be area under tree plantation within the residential & Commercial plots and along the roads, lanes & streets.

Evergreen tall and ornamental trees like *Polyalthia longifolia*, *Ficus infectoria* and ornamental shrubs like *Hibiscus*, *Gardenia florida*, *Plumeria rubra* have been proposed to be planted inside the premises. Parks will also be developed by the management. The organized green area has been proposed in several patterns for school, Education Institutions, Office complex.

1.4 Will there be any significant land disturbance resulting in erosion, subsidence & instability? (Detail of soil type slope analysis, vulnerability to subsidence, seismicity etc may be given).

The project area falls under seismic active Zone III region indicating moderate damage risk zone. The buildings will be designed as earthquake resistant and comply with the required IS specifications.

Soil testing will be done during detailed EIA / EMP study, after the issue of ToR letter and the report of the same will be attached in EIA/ EMP Report.

1.5 Will the proposal involve alteration of natural drainage system? (Give details on a contour map showing the natural drainage near the project site).

No, perennial or non-perennial drainage system is found to exist in the project area or being obstructed by the project. The surroundings comprise an urbanized stretch with rain water drainage system having already being laid by Indore Development Authority and well planned storm water drainage has been designed for internal storm water drainage. Thus, no impact on the natural drainage system is anticipated.

1.6 What are the quantities of earthwork involved in the construction activity-cutting, filling, reclamation etc. (Give details of the quantities of earthwork involved, transport of fill materials from outside the site etc?)

The earthwork shall include soil excavation and cutting of the earth. The cut and fill material in the project site is nearly at par and hence the need for movement of soil to and from the site is not anticipated.

1.7 Give details regarding water supply, waste handling etc. during the construction period.

Sullage generated during the construction phase will be disposed off through soak pits. Waste handling during the construction phase shall be done by the site contractor whose responsibility lies with collection and storage of construction and demolition waste generated on the site. All construction wastes generated during construction will be used within the site itself for filling the floors, roads, aggregate for mortar etc. to the extent feasible. Remaining will be sent to the agency for proper disposal.

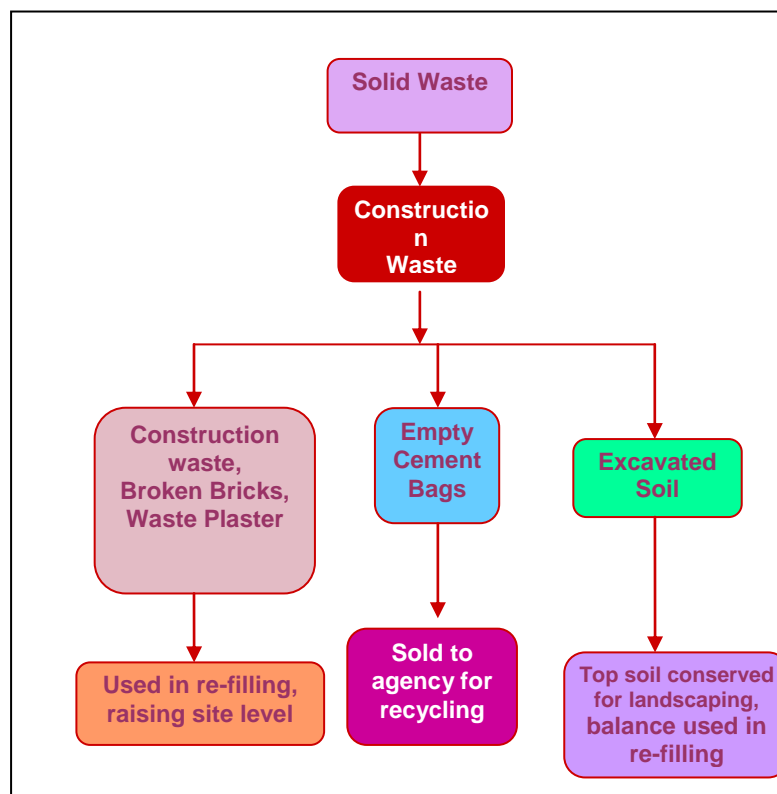

Figure 1: Waste Management Plan for the Construction Phase

1.8 Will the low lying areas & wetlands get altered? (Provide details of how low lying and wetlands are getting modified from the activity).

No. The site area is a flat land and the surroundings are characterized by an urbanized stretch. No low lying areas or wetlands are found in the region.

1.9 Whether construction debris & waste during construction cause health hazard? (Give quantities of various types of wastes generated during construction including the construction labor and the means of disposal).

No health hazards are expected during the construction phase. The laborers will be provided with face masks to minimize dust inhalation.

The remaining waste which will be mostly inert in nature will be transported to a government approved dumping site or recyclablers, so that it can be re used or recycled.

The quantity of domestic waste generated will be very little, as mostly local laborers will be employed. However, the wastes generated will be collected and disposed by an authorized agency.

SECTION 2- WATER ENVIRONMENT

2.1 Give the total quantity of water requirement for the project with the breakup of requirements for various uses. How will the water requirement be met? State the sources & quantities and furnish a water balance statement.

The water supply will be provided through the Indore Development Authority. The total water requirement is approx. 12678 KLD, out of which total domestic water requirement is 10294 KLD. The potable water requirement is approx. 6168 KLD which is 70% of the domestic water demand for residential and 30% of the domestic water for commercial population. The daily water requirement calculation is given below in Table 3:

Table 3: Calculations for Daily Water Demand

S. No.	Description	Total Occupancy	Rate of water demand (lpcd)	Total Water Requirement (KLD)
A.	Domestic Water			
	Residents	57043	135	7700
	Commercial Staff	48858	45	2198
	• Service Staff	5295	45	238
	• Visitors	10590	15	158
Sub Total (A)				10294

B.	Fire Fighting			326
Sub Total (A+B)				10620
C.	Horticulture and Landscape development	263100 m²	1 l/sqm	263.1
D.	Recreational Purposes and Road washing			1795
Grand Total (A+B+C) = 12678 KLD				

Table 6: Wastewater Calculations

Domestic Water Requirement	10294 KLD
Residential(7700 KLD)	
• Fresh (70% of domestic)	5390 KLD
• Flushing (30% of domestic)	2310 KLD
Commercial (staffs + visitors) (2594 KLD)	
• Fresh (30% of domestic)	778
• Flushing (70% of domestic)	1816
Wastewater Generated (80% fresh + 100% flushing)	4394+4126 =9060 KLD

Wastewater Generation & Treatment

It is expected that the project will generate approx 9060 KLD of wastewater. The wastewater will be treated in the STP provided within the project generating 8720 KLD of recoverable water from STP which will be recycled within the project and some surplus water will be discharged to sewer.

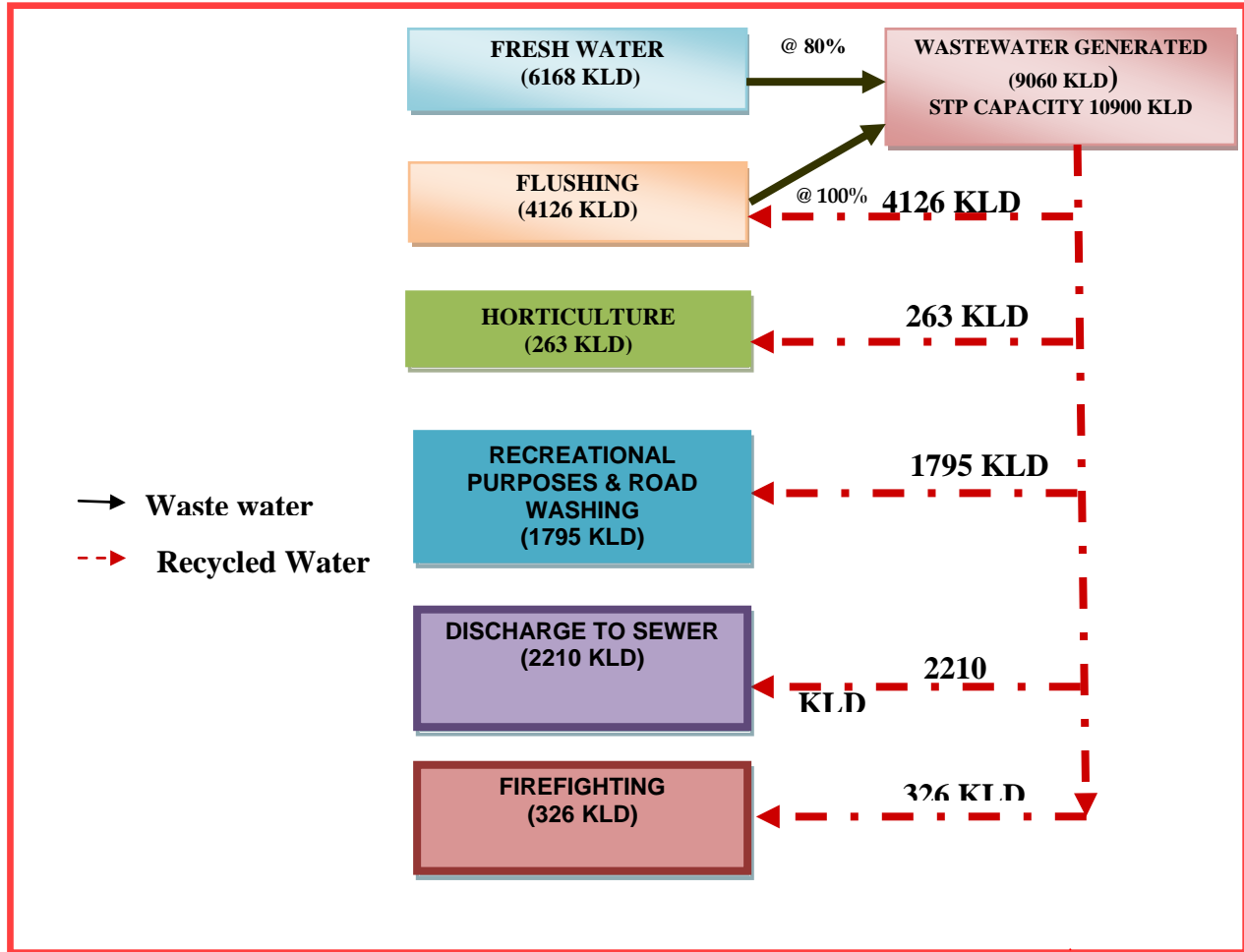

Figure 2: Water Balance Diagram

2.2 What is the quality of water required, in case, the supply is not from a municipal source? (Provide physical, chemical, Biological characteristics with class of water quality).

As the source of water supply to the project is Indore Municipal Corporation, so capacity of Indore Municipal Corporation cannot be defined.

2.3 How much of water requirement can be met from the recycling of treated sullage? (Give the details of quantities, sources and usage)

It is expected that the project will generate approx 9060 KLD of wastewater. The wastewater will be treated in the STP provided within the project generating 8720 KLD of recoverable water from STP which will be recycled within the project and some surplus water will be discharged to sewer.

2.4 Will there be diversion of water from other users? (Please assess the impacts of the project on other existing uses and quantities of consumption).

No. There will not be any diversion of water from other users. Rise in water demand is a local phenomenon but the project would only involve spatial shifting of water demand within a region.

2.5 What is the incremental pollution load from sullage generated from the activity? (Give details of the quantities and composition of sullage generated from the activity)

Approximately, 9060 KLD (@ 80% of the potable water consumed + 100% flushing water) of sullage will be generated during the operational phase from domestic use and other uses. This sullage generated will be treated in well designed sewage treatment plant based on SBR technology.

The following are the input characteristics of the sullage:

Parameter	Raw Sewage (Influent)	Treated Sewage (After Secondary Treatment)	Treated Sewage (After Tertiary Treatment)
pH	6.5-8.5	6.5-8.5	6.5-8.5
BOD3 at 27°C (mg/l)	250-300	<15	<5
COD (mg/l)	600-800	<100	<30
TSS (mg/l)	300-400	<20	<10
Nitrogen (mg/l)	20-25	<10	<5
Phosphorus (mg/l)	up to 10	<5	<5
Oil & grease (mg/l)	up to 100	<5	<2

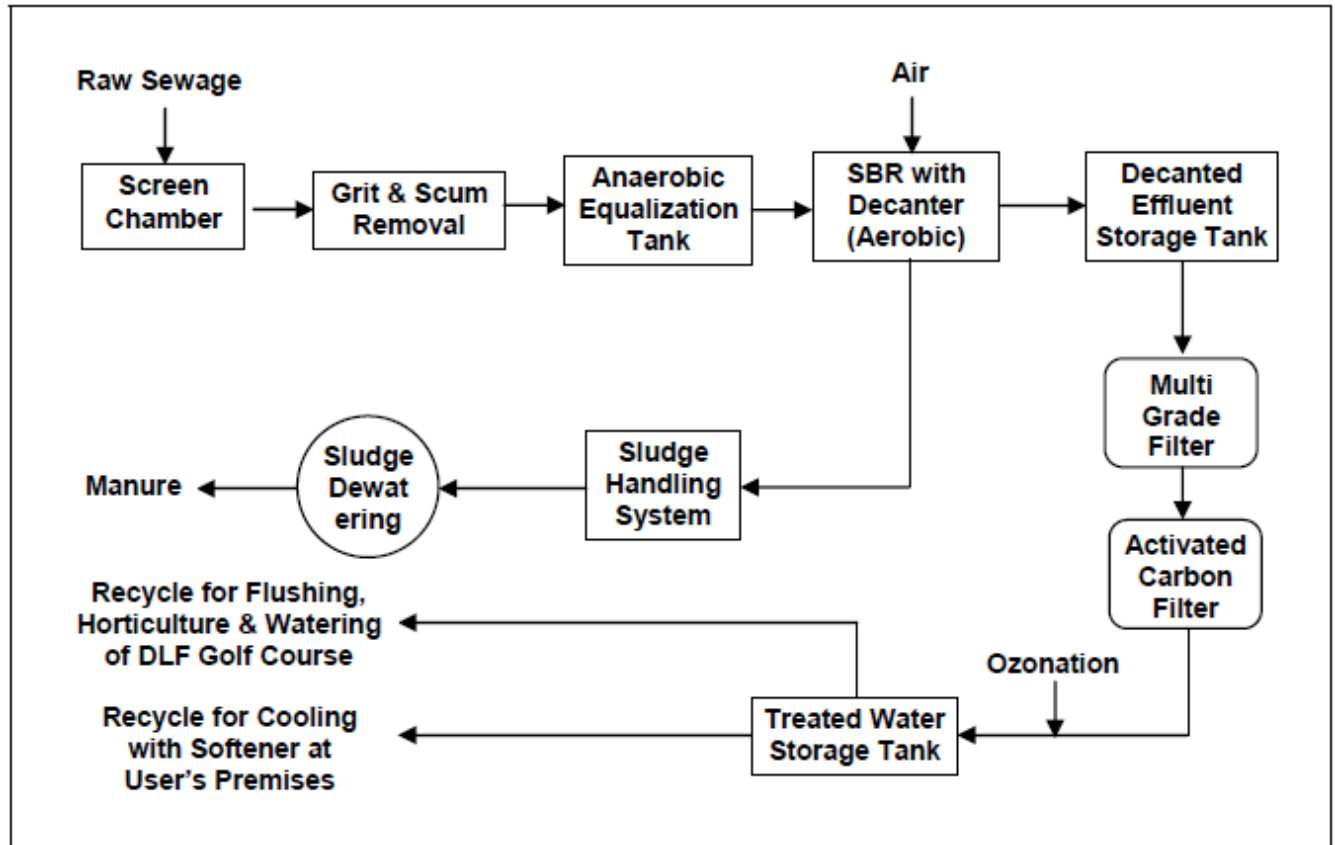

Schematic Diagram of STP

2.6 Give details of the water requirements met from water harvesting? Furnish details of the facilities created.

The storm water disposal system for the premises shall be self-sufficient to avoid any collection/stagnation and flooding of water. The amount of storm water run-off depends upon many factors such as intensity and duration of precipitation, characteristics of the tributary area and the time required for such flow to reach the drains. The drains shall be located near the carriage way along either side of the roads. Taking the advantage of road camber, the rainfall run off from roads shall flow towards the drains. Storm water from various plots/shall be connected to adjacent drain by a pipe through catch basins. Therefore, it has been calculated to provide **85 rainwater harvesting pits** at selected locations, which will catch the maximum run-off from the area.

- 1) Since the existing topography is congenial to surface disposal, a network of storm water pipe drains is planned adjacent to roads. All building roof water will be brought down through rain water pipes.
- 2) Proposed storm water system consists of pipe drain, catch basins and seepage pits at regular intervals for rain water harvesting and ground water recharging.
- 3) For basement parking, the rainwater from ramps will be collected in the basement storm water storage tank. This water will be pumped out to the nearest external storm water drain.
- 4) Average rainfall of 939.1 mm/hr shall be considered for designing the storm water drainage system.

Rain water harvesting has been catered to and designed as per the guideline of CGWA. The recharge pit of adequate radius and depth is constructed for recharging the water. Inside the recharge pit, a recharge bore is constructed having adequate diameter and depth. The ground water level in the area is **10 to 20 meters bgl**. The bottom of the recharge structure will be kept 5 m above this level. At the bottom of the recharge well, a filter media is provided to avoid choking of the recharge bore. Design specifications of the rain water harvesting plan are as follows:

- Catchments/roofs would be accessible for regular cleaning.
- The roof will have smooth, hard and dense surface which is less likely to be damaged allowing release of material into the water. Roof painting has been avoided since most paints contain toxic substances and may peel off.
- All gutter ends will be fitted with a wire mesh screen and a first flush device would be installed. Most of the debris carried by the water from the rooftop like leaves, plastic bags and paper pieces will get arrested by the mesh at the terrace outlet and to prevent contamination by ensuring that the runoff from the first 10-20 minutes of rainfall is flushed off.
- No sewage or wastewater would be admitted into the system.
- No wastewater from areas likely to have oil, grease, or other pollutants has been connected to the system.

Table: Calculations for storm water load

ITEM	Area (m²)	Coefficient of Runoff in standard	Peak hourly rainfall (0.05 m/hr)	Run off load (m³/hr)
Total Area	3557900			102865
1. Area land transferred to Govt.	411400			
a) Infosys	96,000	0.80	0.05	3840
b) TCS	315400	0.80	0.05	12616
2. Other (Exempted + Forest + Aabadi)	157200			
a)Exempted Area	30200	0.80	0.05	1208
b)Area under Aabadi	127,000	0.50	0.05	3175
c)Area under Sector A	894600	0.50	0.05	22365
d)Area under Railway station	6,600	0.50	0.05	165
SUB TOTAL (1+2)	1487400			
NET AVAILABLE AREA= [Total Area – SUB Total (1+2)]	2989300			
NET PLANNING AREA OF Scheme 151(Sec B, C and D) Super Corridor	1487400	0.80	0.05	59496

Total Runoff Load = 102865 m³/hr

Taking 15 minutes Retention Time, Total volume of storm water = 102865/4

$$= 25716.25 \text{ m}^3$$

Taking the effective radius and depth of a Recharge pit 4 m and 6 m respectively, Volume of a single Recharge pit = $\pi r^2h = 3.14 \times 4 \times 4 \times 6 = 301.44 \text{ m}^3$

Hence No. of pits required = 25716.25/301.44 = 85.311 Pits.

Total of 85 Rain Water Harvesting pits are being proposed for artificial rain water recharge within the project premises.

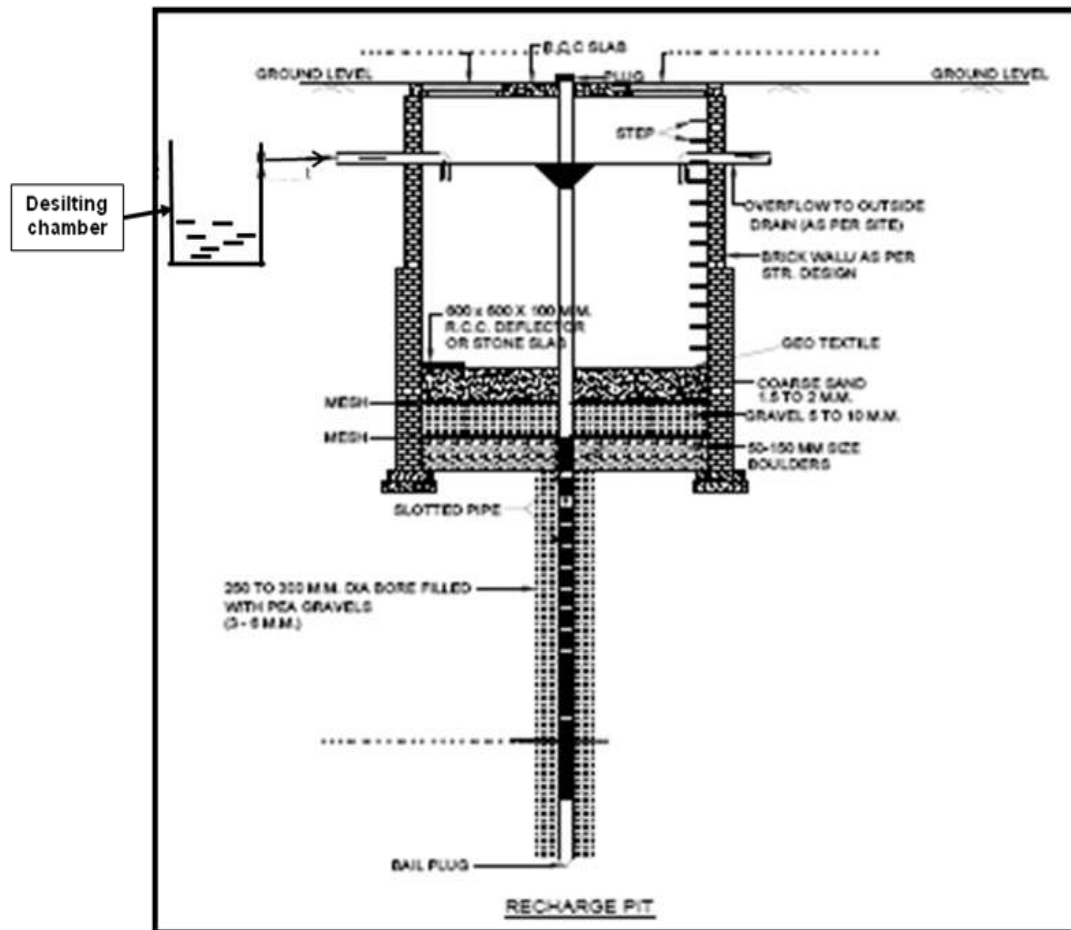

Figure 5: Typical Rain Water Harvesting Pit Design

2.7 What would be the impact of the land use changes occurring due to the project on the runoff characteristics (quantitative as well as qualitative) of the area in the post construction phase on a long term basis? Would it aggravate the problems of flooding or water logging in any way?

The project will include paved areas and thus the runoff from the plot is expected to increase due to reduced infiltration. However, the increased runoff will not cause flooding or water logging as a well designed storm water drainage will be provided. The runoff will finally be collected into

rainwater harvesting pits for groundwater recharging. The quality of the runoff is expected to improve due to paved areas.

2.8 What are the impacts of the proposal on the ground water? (will there be tapping of ground water; give the details of ground water table, recharging capacity and approvals obtained from competent authority, if any)

Water demand will be fulfilled from Indore Development Authority. No adverse impact is expected on this account. To reduce the freshwater demand, treated wastewater will be used for landscaping, DG Sets cooling, flushing & rest will be utilized for nearby construction purposes.

2.9 What precautions/ measures have been to check the surface run-off, as well as uncontrolled flow of water into any water body?

The following management measures are suggested to protect the water quality during construction phase.

- Avoid excavation during monsoon season.
- Care would be taken to avoid soil erosion.
- Community toilets shall be constructed on the site during construction phase and the sullage will be channelized to the septic tank in order to prevent sullage from entering the water bodies.
- Any area with loose debris within the site shall be planted.
- To prevent surface and ground water contamination by oil/grease, leak proof containers would be used for storage and transportation of oil/grease. The floors of oil/grease handling area would be kept effectively impervious.
- Collection and settling of storm water, prohibition of equipment wash downs, and prevention of soil loss and toxic release from the construction site will be adhered to minimize water pollution.

2.10 How is the storm water from within the site managed? (State the provisions made to avoid flooding of the area, details of the drainage facilities provided along with a site layout indication contour levels).

Most of the storm water produced on site will be harvested for ground water recharge. Thus proper management of this resource is a must to ensure that it is free of contamination. A detailed Storm Water Management Plan will be developed which will consider the sources of storm water. The plan will incorporate best management practices which will include the following:

- Regular inspection and cleaning of storm drains.
- Installation of clarifiers or Oil/Water separators system of adequate capacity around parking areas and garages as per requirement.
- Cover waste storage areas.
- Avoid application of pesticides and herbicides before wet season.
- Conducting routine inspections to ensure cleanliness.
- Preparation of spill response plans, particularly for fuel and oil storage areas.
- Provision of silt traps in storm water drains.
- Good housekeeping in the above areas.

2.11 Will the deployment of construction laborers particularly in the peak period lead to unsanitary conditions around the project site (Justify with proper explanation).

No, mostly local laborers will be employed during the construction phase and thus negligible quantities of wastes will be generated. Mobile toilets will be provided and the sullage generated will be collected in septic tanks.

2.12 What on-site facilities are provided for the collection, treatment & safe disposal of sewage? (Give details of the quantities of sullage generation, treatment capacities with technology & facilities for recycling and disposal).

It is expected that the project will generate approx 9060 KLD of wastewater. The wastewater will be treated in the STP provided within the project generating 8720 KLD of recoverable water from STP which will be recycled within the project and some surplus water will be discharged to sewer.

2.13 Give details of dual plumbing system if treated waste used for flushing of toilets or any other use.

Dual plumbing system that utilizes separate piping systems for freshwater and recycled sullage will be adopted for the project. The recycled water system shall utilize this treated sullage and serve for non-contact uses such as flushing, horticulture, Firefighting, Recreational purpose and Decorative foundation and rest will be discharged to sewer.

3. VEGETATION

3.1 Is there any threat of the project to the biodiversity? (Give a description of the local ecosystem with its unique features, if any).

No ecologically sensitive area falls within the project site. Hence, no ecological/ biological threat has been anticipated.

3.2 Will the construction involve extensive clearing or modification of vegetation? (Provide a detailed account of the trees & vegetation affected by the project)

The project does not support any significant vegetation. It is proposed to develop a multilayered peripheral greenbelt of native plant species to enhance the aesthetic value of the region and also provide an excellent habitat for various faunal groups.

3.3 What are the measures to be taken to minimize the likely impacts on important site – features (Give details of proposal for tree plantation, landscaping creation of water bodies etc along with a layout plan to an appropriate scale?)

Total green area measures **263100 m²** i.e. **17.69 %** of the total area which will be area under tree plantation within the residential & Commercial plots and along the roads, lanes & streets. Evergreen tall and ornamental trees *Polyalthia longifolia*, *Ficus infectoria* and ornamental shrubs like *Hibiscus*, *Gardenia florida*, *Plumeria rubra* have been proposed to be planted inside the premises. Parks will also be developed by the management. The organized green area has been proposed in several pattern for school, Education Institutions, Office complex.

4. FAUNA

4.1 Is there likely to be any displacement of fauna both terrestrial and aquatic or creation of barriers for their movement? Provide the details.

No. The existing land use around the site is urban and does not provide a habitat for wild species. A few species of butterfly, avifauna and reptiles were recorded during the course of survey, which are common and found abundantly in this region.

4.2 Any direct or indirect impacts on the avifauna of the area? Provide details.

The project will not have any direct or indirect impacts on the avifauna of the area. However, planting of fruit bearing trees in the greenbelt will be an attraction to the local bird population.

4.3 Prescribe measures such as corridors, fish ladders etc. to mitigate adverse impacts on fauna.

Not applicable.

5. AIR ENVIRONMENT

5.1 Will the project increase atmospheric concentration of gases & result in heat islands? (Give details of background air quality levels with predicted values based on dispersion models taking into account the increased traffic generation as a result of the construction).

Ambient air monitoring will be carried out at the project site during the EIA/ EMP study, after issue of ToR letter and the report of the same will be attached in EIA/ EMP Report.

5.2 What are the impacts on generation of dust, smoke, odorous fumes or other hazardous gases? Give details in relation to all the meteorological parameters.

Ambient air monitoring will be carried out at the project site during the EIA/ EMP study, after issue of ToR letter and the report of the same will be attached in EIA/ EMP Report.

5.3 Will the proposal create shortage of parking space for vehicles? Furnish details of the present level of transport infrastructure and measures for improvement including the traffic management at the entry and exit to the project site.

As this is the plotted project Area development of Scheme 151(Sec B, C and D), Super Corridor developed by Indore Development Authority, the respective plots (Commercial/Residential) will be built up by the respective owner/developer of the plot. Therefore, the development of each of these plots by individual will be undertaken as per the state bye laws, under the supervision of experts. Adequate provision will be made for car/vehicle parking at each proposed project plot. There shall also be adequate parking provisions for visitors so as not to disturb the traffic and allow smooth movement along the corridor & in the nearby areas.

5.4 Provide details of the movement patterns with internal roads, bicycle tracks, pedestrian pathways, footpaths etc, with areas under each category.

The internal roads, footpaths/pedestrian pathways have been well planned for the project.

5.5 Will there be significant increase in traffic noise & vibrations? Give details of the sources and the measures for mitigation of the above.

No significant impact of noise has been anticipated within and outside of the project site due to provision of wide roads for smooth flow of traffic and greenbelt along the roads. Noise, due to the traffic, within site, will result in a marginal increase in the noise levels, which will cause slight increase in noise level.

5.6 What will be the impact of D.G. sets and other equipment on noise levels and vibration in ambient air quality around the project site? Provide details.

1. The DG sets will be installed by the individuals purchasing the plot (Residential /Commercial) from Indore Development Authority. The back up DG sets in these individual plots will be installed as per their work requirements & electricity load requirement. The DG sets will be equipped with acoustic enclosure to minimize noise generation and adequate stack height for proper dispersion.
2. For public lighting, 30 percent street lights on major junctions will be will provided solar power back up, as proposed.

6. AESTHETICS

6.1 Will the construction in any way result in the obstruction of a view, scenic amenity or landscapes? Are these considerations taken into account by the proponents?

The site lies in an urbanized settlement and is well planned. Thus, no obstruction of view or scenic beauty or landscape is anticipated. Furthermore, the construction will be planned in such a way that the organized open spaces and landscaped areas will render the plot aesthetically appealing.

6.2 Will there be any adverse impacts from new constructions on the existing structures? What are the considerations taken into account?

No impacts anticipated.

6.3. Whether there are any local considerations of urban form & urban design influencing the design criteria? They may be explicitly spelt out.

The project will strictly follow the Area Building Regulation of NBC. All norms on Ground Coverage, FAR, Height, Setbacks, Fire Safety Requirements, Structural Design and other parameters will be strictly adhered to.

6.4 Are there any anthropological or archaeological sites or artifacts nearby? State if any other significant features in the vicinity of the site have been considered?

No anthropological or archaeological sites or artifacts are found near the site area.

7. SOCIO-ECONOMIC ASPECTS

7.1 Will the proposal result in any changes to the demographic structure of local population? Provide the details.

No such changes anticipated.

Construction phase: Since local labourers will be engaged during construction phase, alteration to the existing demographic profile of the area is not anticipated.

Operation phase: The changing demography in the area is another impact that needs attention. The project will mainly lead to spatial redistribution of local population and hence no considerable influx of population is envisaged owing to the project.

7.2 Give details of the existing social infrastructure around the project.

The area around the project is surrounded by local land area. Areas occupied by sensitive man-made land uses like hospitals, schools, places of worship etc.

1.	Vijay Nagar	Approx. 2 Km
2.	Sukhliya	Approx. 1 Km
3.	Nehru Nagar	Approx. 3.3 Km
4.	Rajshree Hospital	Approx. 1.29 Km
5.	Bhandari Hospital	Approx. 2 Km
6.	Mount Carmel School	Approx. 0.83 Km
7.	ITI College	Approx. 0.72 Km
8.	Hanuman Mandir	Approx. 2 Km
9.	Ralamandal Wildlife Sanctuary	Approx. 13.2 Km

7.3 Will the project cause adverse effects on local communities, disturbance to sacred sites or other cultural values? What are the safeguards?

Construction phase: There are no religious sites or archeological monuments of historical significance on the project site. Hence, no adverse impact in this regard is anticipated. Rather, this phase will generate jobs that relate to unskilled, semi skilled as well as skilled labour category. Few supervisory positions will also open up, for which local candidates will be considered based on merit.

Operation phase: The project will provide Commercial, Residential, Educational etc. facility in the area, thereby improving the quality of life. A Super Corridor project of such scale will also boost the local economy.

8. BUILDING MATERIALS

8.1 May involve the use of building materials with high embodied energy. Are the construction materials produced with energy efficient processes? (Give details of energy conservation measures in the selection of building materials and their energy efficiency)

For the purpose of paved path, sun dried pavers will be used instead of baked pavers as they are manufactured through energy efficient processes.

8.2 Transport and handling of materials during construction may results in pollution, noise and public nuisance. What measures are taken to minimize the impacts?

Mitigation Measures for Air Pollution during Construction Stage:

- Construction materials will be suitably covered with tarpaulin cover etc during transportation.
- Water sprinkling shall be done on haul roads where dust generation is anticipated.
- Raw material storage and handling yard will be enclosed from all sides.
- To minimize the occupational health hazard, proper personal protective gears i.e. mask shall be provided to the workers working in the dust prone areas.

Mitigation Measures for Noise Pollution during Construction Stage:

- Administrative as well as engineering control of noise will be implemented.
- Isolation of noise generation sources and temporal differentiation of noise generating activities will ensure minimum noise at receiver’s end.
- To prevent any occupational hazard, earmuff / earplug shall be given to the workers working around construction plant & machinery emitting high noise levels.
- Use of such plant or machinery shall not be allowed during night time. Careful planning of machinery operation and scheduling of operations shall be done to minimise such impact.

8.3 Are recycled materials used in roads and structures? State the extent of savings achieved?

Yes, for road construction fly-ash will be utilized. Recycled materials will be bought from outside sources and will be used as fillers in base and sub-base of the carriageway, footpaths pavements or pedestrian way, as needed.

8.4 Give detail of the methods of collection, segregation & disposal of the garbage generated during the operation phases of the project.

The solid waste of the project will be segregated into biodegradable waste and non-biodegradable. Biodegradable waste and non biodegradable waste will be collected in separate bins. Biodegradable waste will be treated in the project premises by organic waste convertor. The recyclable wastes will be sent off to recyclabers. Proper guidelines for segregation, collection and storage will be prepared as per Municipal Solid Wastes (Management and Handling) Rules, 2000 and amended Rules, 2008.

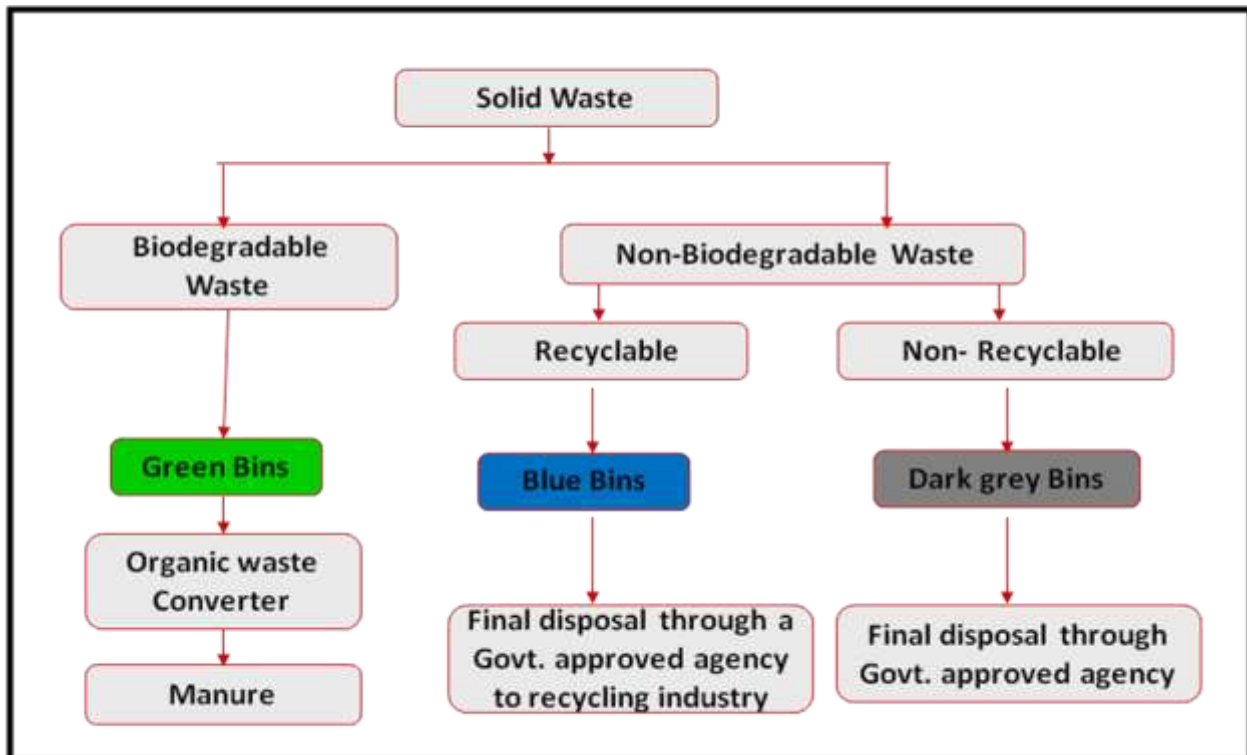

Figure 6: Solid Waste Management Scheme (Operation Phase)

9. ENERGY CONSERVATION

9.1 Give details of the power requirements, source and supply, backup source etc. What is the energy consumption assumed per square foot of built-up area? How have you tried to minimize energy consumption?

The DG sets will be installed by the individuals purchasing the plot (Residential /Commercial) from Indore Development Authority. The back up DG sets in these individual plots will be installed as per their work requirements & electricity load requirement. The DG sets will be equipped with acoustic enclosure to minimize noise generation and adequate stack height for proper dispersion.

For public lighting, 30 percent street lights on major junctions will be will provided solar power back up, as proposed.

9.2 What type and capacity of power backup do you plan to provide?

1. The DG sets will be installed by the individuals purchasing the plot (Residential /Commercial) from Indore Development Authority. The back up DG sets in these individual plots will be installed as per their work requirements & electricity load requirement. The DG sets will be equipped with acoustic enclosure to minimize noise generation and adequate stack height for proper dispersion.

2. For public lighting, 30 percent street lights on major junctions will be will provided solar power back up, as proposed.

9.3 What are the characteristics of the glass you plan to use? Provide specifications of its characteristics related to both short wave and long wave radiation?

- The project will involve uses of laminated glass having **U value** 2.84 W/sq. m. K for 3 mm thick clear to 5.96 W/sq. m. K for 6 mm thick clear.

(NOTE; Uses- in office buildings, hotels, restaurants, shopping malls, public walkways, hospitals, libraries, museums, churches, airport terminals, residences & apartment buildings, noise control applications, embassies, computer centers)

9.4 What passive solar architectural features are being used in the building? Illustrate the applications made in the project.

Passive solar design refers to use of the sun’s energy for the heating and cooling of living spaces. Pergolas, projections, façade elements, metal louvers will be provided for sun shading to reduce the heat influx into the building and thus reduce the air conditioning loads.

9.5 Does the layout of street & building maximize the potential for solar energy devices? Have you considered the use of street lighting, emergency lighting and solar hot water systems for use in the building complex? Substantiate with details.

Layout of buildings has been done as per the sun path analysis so that the design cuts off direct radiations of critical hours which are specific to the orientation. Solar energy will be harnessed to meet various energy requirements of the project such as:

- Solar street lights.
- Solar blinkers.

9.6 Is the shading effectively used to reduce cooling/heating loads? What principles have been used to maximize the shading of walls on the East and the West and the Roof? How much energy saving has been effected?

Pergolas, projection, façade elements, metal louvers will be provided to reduce cooling loads. Green area and open areas will be so spaced that a reduction in temperature is achieved.

9.7 Do the structures use energy-efficient space conditioning, lightening and mechanical systems? Provide technical details. Provide details of the transformers and motor efficiencies, lightening intensity and air conditioning load assumption? Are you using CFC and HCFC free chillers? Provide specifications.

Yes. The walls and rooms will be insulated such that air conditioning load is reduced. Well designed building structures will allow natural light to enter. Measures prescribed in Energy Conservation Building Code 2007 will be adopted to reduce the heat influx by walls, roofs and openings. Only prescribed quality of glasses will be used.

9.8 What are the likely effects of the building activity in altering the micro-climates? Provide a self assessment on likely impacts of the construction on creation of heat island & inversion effects?

Heat emissions from the construction may be from the following sources:

- Heat absorbed from the paved and concrete structures
- Heat generated from equipment/appliances
- Heat increase due to population increase in the project.

However, the heat generated will not be significant and will be dissipated in the greens and open areas provided within the project area.

9.9 What are the thermal characteristics of the building envelope? (a) Roof (b) external walls and (c) fenestration? Give details of the material used and the U value or the R values of the individual components.

The roof tops of the buildings will be planned with puffing/bricks bat coba for water proofing and reflective tiles.

External wall-external opening will have regular door windows with slightly tinted glass. Regular walls have some cladding/fixture paints. The ECBC guidelines will be followed by the particular owner.

9.10 What precautions & safety measures are against fire hazards? Furnish details of emergency plans.

Firefighting measures shall be adopted as per the guidelines of NBC. External yard hydrants shall be installed around all buildings in the project in galvanized steel fire house cabinet (weather proof). All external yard hydrants shall be at one meter height from finished ground level as per NBC at a distance of 60 m along the road. External fire hydrants shall be located such that no portion of any building is more than 45 m from a hydrant and the external hydrants are not vulnerable to mechanical or vehicular damage.

Fire hydrant system will be provided within the buildings, fire escape staircases and refuge areas will be provided and the building structures will be planned as per NBC. 10 kg fire extinguishers will be provided for class A, B, and C fires. CO₂ extinguishers will also be provided.

Disaster Management Plan

PRECAUTION & MITIGATORY METHODS TO PREVENT DISASTERS:

- Project is planned to reduce the impact of disasters and to encourage recovery.
- A disaster management cell would be established which will take care of post disaster scenario.
- It would be a volunteer kind of set-up and professionals can also be hired in case of eventuality.

PRECAUTION & MITIGATORY METHODS TO PREVENT DISASTERS:

(Earthquake Management)

- At the time of designing and constructing the building due care would be taken to have earthquake resistant structures which will conform to IS 1983.
- New systems and devices using non-conventional civil engineering materials would be developed to reduce the earthquake forces acting on structure.

PRECAUTION & MITIGATORY METHODS TO PREVENT DISASTERS:

(Fire Hazard)

- Fire safety would be taken into account and would follow all the safety norms and regulations as per the NBC and other related Indian Standards.
- All electrical cables would be underground and sophisticated modern electrical distribution system to reduce risk of fire.
- Special fire fighting equipments like Automatic Fire Detection and alarm system, automatic Sprinkler System etc. would be installed as per the NBC standards.
- Risk assessment with on site disaster management plan will be specified to fire, smoke and other emergency conditions.

9.11 If you are using glass as wall materials, provide details and specifications including emissivity and thermal characteristics.

The project being an area development, it will not involve use of glass as wall material. All fenestration with U-factors, SHGC, or visible light transmittance determined, certified and labeled in accordance ISO 15099 shall be adopted.

9.12 What is the rate of air infiltration in to the building? Provide details of how you are mitigating the effects of infiltration.

The project will not be centrally air conditioned and hence there will be provision for ample natural ventilation in most of the plotted constructions e.g. Group housing, warehousing etc. & few commercial plotted developments will be well equipped with air conditions as per the requirement.

9.13 To what extent the non-conventional energy technologies are utilized in the overall energy consumption? Provide details of the renewable energy technologies used.

Solar energy will be variedly used as:

- Solar street lights.
- Solar blinkers.
- Green CFLs will be used in buildings to minimize the energy consumption.
- Green area is provided along with tree plantation which will result in natural air cooling and will reduce the load on conventional energy sources.

10. ENVIRONMENT MANAGEMENT PLAN

The Environment Management Plan (EMP) would consist of all mitigation measures for each component of the environment due to the activities increased during the construction, operation and the entire life cycle to minimize adverse environmental impacts resulting from the activities of the project. It would also delineate the environmental monitoring plan for compliance of various environmental regulations. It will state the steps to be taken in case of emergency such as accidents at the sites including fire. The detailed EMP for the project is given below.

10.1 Environmental Management Plan

The Environment Management Plan (EMP) is a site specific plan developed to ensure that the project is implemented in an environmental sustainable manner where all contractors and subcontractors, including consultants, understand the potential environmental risks arising from the project and take appropriate actions to properly manage that risk. EMP also ensures that the project implementation is carried out in accordance with the design by taking appropriate mitigation actions to reduce adverse environmental impacts during its life cycle. The plan outlines existing and potential problems that may adversely impact the environment and recommends corrective measures where required. Also, the plan outlines roles and responsibility of the key personnel and contractors who will be in-charge of the responsibilities to manage the project site.

10.1.1 The EMP is generally

- Prepared in accordance with rules and requirements of the MoEF and CPCB/ SPCB
- To ensure that the component of facility are operated in accordance with the design
- A process that confirms proper operation through supervision and monitoring
- A system that addresses public complaints during construction and operation of the facilities and
- A plan that ensures remedial measures is implemented immediately.

The key benefits of the EMP are that it offers means of managing its environmental performance thereby allowing it to contribute to improved environmental quality. The other benefits include cost control and improved relations with the stakeholders.

EMP includes four major elements:

- Commitment & Policy: The management will strive to provide and implement the Environmental Management Plan that incorporates all issues related to air, water, land and noise.
- Planning: This includes identification of environmental impacts, legal requirements and setting environmental objectives.
- Implementation: This comprises of resources available to the developers, accountability of contractors, training of operational staff associated with environmental control facilities and documentation of measures to be taken.

- Measurement & Evaluation: This includes monitoring, counteractive actions and record keeping.

It is suggested that as part of the EMP, a monitoring committee would be formed by Indore Development Authority comprising of the site in-charge/coordinator, environmental group representative and project implementation team representative. The committee’s role would be to ensure proper operation and management of the EMP including the regulatory compliance.

The components of the environmental management plan, potential impacts arising, out of the project and remediation measures are summarized below in Table 12.

TABLE 12: SUMMARY OF POTENTIAL IMPACTS AND REMEDIAL MEASURES

S. No.	Environmental components	Potential Impacts	Potential Source of Impact	Controls Through EMP & Design	Impact Evaluation	Remedial Measures
1.	Ground Water Quality	Ground Water Contamination	<u>Construction Phase</u> <ul style="list-style-type: none"> Sullage generated from temporary labor tents. 	<ul style="list-style-type: none"> No surface accumulation will be allowed. 	No significant impact as majority of labors would be locally deployed	
			<u>Operation Phase</u> <ul style="list-style-type: none"> Discharge from the project 	<ul style="list-style-type: none"> Proponent will provide the STP to treat the discharge of Super Corridor. 	No negative impact on ground water quality envisaged. Not significant.	
2.	Ground Water Quantity	Ground Water Depletion	<u>Construction Phase</u> <ul style="list-style-type: none"> No Use of ground water for construction activity. 	<ul style="list-style-type: none"> Not Applicable. 	No significant impact on ground water quantity envisaged.	

**“AREA DEVELOPMENT OF SCHEME 151(Sec B, C and D), SUPER CORRIDOR”
INDORE, M.P.”**

FORM 1 A

			<p><u>Operation Phase</u></p> <ul style="list-style-type: none"> The source of water during operation phase will be provided by IDA. 	<ul style="list-style-type: none"> Rain water harvesting scheme. Black and Grey water treatment and reuse. Storm water collection for water harvesting. Percolation well to be introduced in landscape plan. Awareness Campaign to reduce the water consumption 	<p>No significant impact on surface/ground water quantity envisaged.</p>	<p>In an unlikely event of non-availability of water supply, water will be brought using tankers.</p>
--	--	--	---	--	--	---

**“AREA DEVELOPMENT OF SCHEME 151(Sec B, C and D), SUPER CORRIDOR”
INDORE, M.P.”**

FORM 1 A

3.	Surface Water Quality	Surface water contamination	<u>Construction Phase</u> <ul style="list-style-type: none"> • Surface runoff from site during construction activity. 	<ul style="list-style-type: none"> • Silt traps and other measures such as additional on site diversion ditches will be constructed to control surface run-off during site development 	No off-site impact envisaged as no surface water receiving body is present in the core zone.	
			<u>Operation Phase</u> <ul style="list-style-type: none"> • Discharge of domestic sullage to STP. 	<ul style="list-style-type: none"> • Domestic wastewater will be treated in STP 	No off-site impact envisaged	Excess of treated water will be discharged after proper treatment. CPCB standards for usage of treated sullage for landscaping purposes will be followed.
4.	Air Quality	Dust Emissions	<u>Construction Phase</u> <ul style="list-style-type: none"> • All heavy construction 	<ul style="list-style-type: none"> • Suitable control measures will 	Not significant because dust generation will	During construction phase the contractors are advised to facilitate masks for the

**“AREA DEVELOPMENT OF SCHEME 151(Sec B, C and D), SUPER CORRIDOR”
INDORE, M.P.”**

FORM 1 A

			activities	be adopted for mitigating the PM _{2.5} & PM ₁₀ level in the air as per air pollution control plan.	be temporary and will settle fast due to dust suppression techniques.	labors. Water sprinklers will be used for suppression of dust during construction phase.
		Emissions of PM _{2.5} & PM ₁₀ , SO ₂ , NO ₂ and CO	<u>Construction Phase</u> <ul style="list-style-type: none"> • Operation of construction equipment and vehicles during site development. • Running D.G. set (back up) 	<ul style="list-style-type: none"> •Rapid on-site construction and improved maintenance of equipment 	Not significant.	Regular monitoring of emissions and control measures will be taken to reduce the emission levels.
			<u>Operation Phase</u> <ul style="list-style-type: none"> • Power generation by DG Set during power failure 	<ul style="list-style-type: none"> •Use of low sulphur diesel if available •Providing Footpath and 	Not significant. DG set would be used as power back-up (approx 8 hours)	<ul style="list-style-type: none"> • Use of Personal Protective Equipment (PPE) like earmuffs and earplugs during construction activities.

**“AREA DEVELOPMENT OF SCHEME 151(Sec B, C and D), SUPER CORRIDOR”
INDORE, M.P.”**

FORM 1 A

			<ul style="list-style-type: none"> Emission from vehicular traffic in use 	<p>pedestrian ways within the site for the residents</p> <ul style="list-style-type: none"> Green belt will be developed with specific species to help to reduce PM_{2.5} & PM₁₀ level Use of equipment fitted with silencers Proper maintenance of equipment 	<p>No significant increase in ambient air quality level is expected from the project's activities.</p> <p>There are no sensitive receptors located within the vicinity of site.</p>	<ul style="list-style-type: none"> Stack height of DG set above the tallest building as per CPCB standards
5.	Noise Environment					

**“AREA DEVELOPMENT OF SCHEME 151(Sec B, C and D), SUPER CORRIDOR”
INDORE, M.P.”**

FORM 1 A

			<p><u>Operation Phase</u></p> <ul style="list-style-type: none"> • Noise from vehicular movement • Noise from DG set operation 	<ul style="list-style-type: none"> • Green Belt Development •Development of silence zones to check the traffic movement •Provision of noise shields near the heavy construction operations and acoustic enclosures for DG set. •Construction activity will be limited to day time 	<p>No significant impact due to suitable width of Avenue plantation.</p>	
--	--	--	--	---	--	--

**“AREA DEVELOPMENT OF SCHEME 151(Sec B, C and D), SUPER CORRIDOR”
INDORE, M.P.”**

FORM 1 A

				hours only <ul style="list-style-type: none"> • DG set rooms will be equipped with acoustic enclosures 		
6.	Land Environment	Soil contamination	<u>Construction Phase</u> <ul style="list-style-type: none"> • Disposal of construction debris 	Construction debris will be collected and suitably used on site as per the solid waste management plan for construction phase	No significant impact. Impact will be local, as waste generated will be reused for filling of low lying areas etc.	
			<u>Operation Phase</u> <ul style="list-style-type: none"> • Generation of municipal 	<ul style="list-style-type: none"> • It is that the solid waste generated will be managed 	Since solid waste is handled by the authorized	

**“AREA DEVELOPMENT OF SCHEME 151(Sec B, C and D), SUPER CORRIDOR”
INDORE, M.P.”**

FORM 1 A

			<p>solid waste</p> <ul style="list-style-type: none"> • Used oil generated from D.G. set 	<p>as per MSW Rules, 2000 and amended Rules, 2008.</p> <ul style="list-style-type: none"> • Collec tion, segregation, transportation and disposal will be done as per MSW Management Rules, 2000 by the authorized agency • Used oil generated will be sold to authorized recyclers 	<p>agency, waste dumping is not going to be allowed. Not significant.</p> <p>Negligible impact.</p>	
--	--	--	---	---	---	--

**“AREA DEVELOPMENT OF SCHEME 151(Sec B, C and D), SUPER CORRIDOR”
INDORE, M.P.”**

FORM 1 A

7.	Biological Environment (Flora and Fauna)	Displacement of Flora and Fauna on site	<u>Construction Phase</u> <ul style="list-style-type: none"> • Site Development during construction 	<ul style="list-style-type: none"> • Import ant species of trees, if any, will be identified and marked and will be merged with landscape plan 	The site has shrubs as vegetation	
			<u>Operation Phase</u> <ul style="list-style-type: none"> • Increase in green covered area 	<ul style="list-style-type: none"> • Suitable green belts will be developed as per landscaping plan in and around the site using local flora 	Beneficial impact.	

**“AREA DEVELOPMENT OF SCHEME 151(Sec B, C and D), SUPER CORRIDOR”
INDORE, M.P.”**

FORM 1 A

8.	Socio- Economic Environment	Population displacement and loss of income	<u>Construction Phase</u> <ul style="list-style-type: none"> • Construction activities leading to relocation 	As this is the plotted project Area development of Scheme 151(Sec B, C and D), Super Corridor by Indore Development Authority, the respective plots (Commercial/ Residential) will be built up by the respective owner/developer of the plot.	No negative impact.	
----	-----------------------------------	---	---	---	---------------------	--

**“AREA DEVELOPMENT OF SCHEME 151(Sec B, C and D), SUPER CORRIDOR”
INDORE, M.P.”**

FORM 1 A

				<p>Therefore, the development of each of these plots by individual will be undertaken as per the state bye laws, under the supervision of experts.</p> <p>Socio-economic study will be done during detailed EIA / EMP study, after the issue of ToR letter and the report</p>		
--	--	--	--	---	--	--

**“AREA DEVELOPMENT OF SCHEME 151(Sec B, C and D), SUPER CORRIDOR”
INDORE, M.P.”**

FORM 1 A

				of the same will be attached in EIA/ EMP Report.		
			<p><u>Operation Phase</u></p> <ul style="list-style-type: none"> • Site operation 	<ul style="list-style-type: none"> • Project will provide employment opportunities to the local people in terms of labor during construction and service personnel (guards, securities, gardeners etc) during 	Beneficial impact	

**“AREA DEVELOPMENT OF SCHEME 151(Sec B, C and D), SUPER CORRIDOR”
INDORE, M.P.”**

FORM 1 A

				operations <ul style="list-style-type: none"> • Provid ing quality- Integrated infrastructure. 		
9.	Traffic Pattern	Increase of vehicular traffic	<u>Construction Phase</u> <ul style="list-style-type: none"> • Heavy Vehicular movement during construction 	<ul style="list-style-type: none"> • Heavy Vehicular movement will be restricted to daytime only and adequate parking facility will be provided 	No negative impact	
			<u>Operation Phase</u> <ul style="list-style-type: none"> • Traffic due to residents, staff and visitors once the 	<ul style="list-style-type: none"> • Vehicular movement will be regulated inside the project with 	No major significant impact as green belt will be developed which will help	

**“AREA DEVELOPMENT OF SCHEME 151(Sec B, C and D), SUPER CORRIDOR”
INDORE, M.P.”**

FORM 1 A

			project is operational	adequate roads and for the parking individual plot owner will be responsible.	in minimizing the impact on environment.	
--	--	--	---------------------------	---	--	--

10.2 ENVIRONMENT MANAGEMENT PLAN

An Environmental Management Plan (EMP) will be required to mitigate the predicted adverse environmental impacts during construction and operation phase of the project and these are discussed in later subsections.

10.2.1 EMP for Air Environment

Construction Phase

To mitigate the impacts of PM₁₀ & PM_{2.5} during the construction phase of the project, the following measures are recommended for implementation:

- A dust control plan
- Procedural changes to construction activities

Dust Control Plan

The most cost-effective dust suppressant is water because water is easily available on construction site. Water can be applied using water trucks, handled sprayers and automatic sprinkler systems. Furthermore, incoming loads could be covered to avoid loss of material in transport, especially if material is transported off-site.

Procedural Changes to Construction Activities

Idle time reduction: Construction equipment is commonly left idle while the operators are on break or waiting for the completion of another task. Emission from idle equipment tends to be high, since catalytic converters cool down, thus reducing the efficiency of hydrocarbon and carbon monoxide oxidation. Existing idle control technologies comprises of power saving mode, which automatically off the engine at preset time and reduces emissions, without intervention from the operators.

Improved Maintenance: Significant emission reductions can be achieved through regular equipment maintenance. Contractors will be asked to provide maintenance records for their fleet as part of the contract bid, and at regular intervals throughout the life of the contract. Incentive provisions will be established to encourage contractors to comply with regular maintenance requirements.

Reduction of On-Site Construction Time: Rapid on-site construction would reduce the duration of traffic interference and therefore, will reduce emissions from traffic delay.

Operation Phase

To mitigate the impacts of pollutants from DG set and vehicular traffic during the operational phase of the Complex, following measures are recommended for implementation:

- DG set emission control measures
- Vehicular emission controls and alternatives
- Greenbelt development

Diesel Generator Set Emission Control Measures

Adequate stack height will be maintained to disperse the air pollutants generated from the operation of DG set to dilute the pollutants concentration within the immediate vicinity. Hence no additional emission control measures have been suggested.

Vehicle Emission Controls and Alternatives

During construction, vehicles will be properly maintained to reduce emission. As it is a Super Corridor, vehicles will be generally having “PUC” certificate.

Footpaths and Pedestrian ways: Adequate footpaths and pedestrian ways would be provided at the site to encourage non-polluting methods of transportation.

Avenue Plantation Development

Increased vegetation in the form of avenue plantation is one of the preferred methods to mitigate air and noise pollution. Plants serve as a sink for pollutants, act as a barrier to break the wind speed as well as allow the dust and other particulates to settle on the leaves. It also helps to reduce the noise level at large extent. The following table indicates various species of the greenbelt that can be used to act as a barrier.

Table 13: Trees to be planted in the premises of the Super Corridor

SR. NO.	BOTANICAL NAME	LOCAL NAME
Plant Species for Roadside		
1.	Toona ciliata	Tun
2.	Ficus infectoria	Pilkhan
3.	Alstonia scholaris	Chhataun
4.	Saraca asoka	sita
5.	Grevillea robusta	Silver oak
6.	Swietenia mahogany	Mahagony
Plants for Residential areas		
1.	Tabernaemontana coronaria	Chandani
2.	Cestrum nocturnum	Rat Ki Rani
3.	Gardenia florida	Gandhraj
4.	Murraya	Kashipatta
5.	Cassia fistula	Amaltas
Plants for Lawn & Gardens		
1.	Ficus Glomerata	Gular
2.	Terminalia bellirica	Bahera
3.	Polyalthia longifolia	Ashoka
4.	Jacaranda mimosaeifolia	Jacaranda
Shrubs		
1.	Plumeria rubra	Red plumeria
2.	Hibiscus	Gurhal
3.	Gardenia florida	Gandhraj

(Source: Guidelines for developing Green Belts by CPCB, 2000)

10.2.2 EMP FOR NOISE ENVIRONMENT

Construction Phase

To mitigate the impacts of noise from construction equipment during the construction phase on the site, the following measures are recommended for implementation.

Time of Operation: Noisy construction equipment would not be allowed to use at night time.

Job Rotation and Hearing Protection: Workers employed in high noise areas will be employed on shift basis. Hearing protection such as earplugs/muffs will be provided to those working very close to the noise generating machinery.

Operation Phase

To mitigate the impacts of noise from diesel generator set during operational phase, the following measures are recommended:

- Adoption of Noise emission control technologies
- Greenbelt development

Noise Emission Control Technologies

1. The DG sets will be installed by the individuals purchasing the plot (Residential /Commercial) from Indore Development Authority. The back up DG sets in these individual plots will be installed as per their work requirements & electricity load requirement. The DG sets will be equipped with acoustic enclosure to minimize noise generation and adequate stack height for proper dispersion.
2. For public lighting, 30 percent street lights on major junctions will be will provided solar power back up, as proposed.

DG set will be housed in a suitable acoustic enclosure so that noise level at a distance of 1 m does not exceed 75 dB(A) at 75% load, as per CPCB standards or is meeting the local standard (whichever is higher).

Greenbelt Development

The following species can be used, as in a greenbelt, to serve as noise breakers:

- *Alstonia scholaris* Devil tree
- *Albizia procera* Safed Siris
- *Albizia lebbek* Woman's tongues Tree
- *Adenanthera pavonina* Peacock flower fence

10.2.3 EMP FOR WATER ENVIRONMENT

Construction Phase

To prevent degradation and to maintain the quality of the water source, adequate control measures have been. The following management measures are suggested to protect the water source being polluted during the construction phase:

- Avoid excavation during monsoon season
- Care would be taken to avoid soil erosion
- Common toilets will be constructed on site during construction phase and the sullage would be channelized to the septic tanks in order to prevent sullage to enter into the water bodies
- Any area with loose debris within the site shall be planted
- To prevent surface and ground water contamination by oil and grease, leak-proof containers would be used for storage and transportation of oil and grease. The floors of oil and grease handling area would be kept effectively impervious. Any wash off from the oil and grease handling area or workshop shall be drained through imperious drains
- Collection and settling of storm water, prohibition of equipment wash downs and prevention of soil loss and toxic release from the construction site are necessary measure to be taken to minimize water pollution
- All stacking and loading area will be provided with proper garland drains, equipped with baffles, to prevent run off from the site, to enter into any water body.

Operation Phase

In the operation phase of the project, water conservation and development measures will be taken, including all possible potential for rain water harvesting. Following measures will be adopted:

- Water source development.
- Minimizing water consumption.

-
- Promoting reuse of water after treatment and development of closed loop systems for different water streams.

Water Source Development

Water source development shall be practiced by installation of scientifically designed Rain Water Harvesting system. Rainwater harvesting promotes self-sufficiency and fosters an appreciation for water as a resource.

Minimizing Water Consumption

Consumption of fresh water will be minimized by combination of water saving devices and other domestic water conservation measures. Further, to ensure ongoing water conservation, an awareness program will be introduced for the residents. The following section discusses the specific measures, which shall be implemented:

Domestic and Commercial Usage

- Use of water efficient plumbing fixtures (ultra flow toilets, low flow sinks, water efficient dishwashers and washing machines). Water efficient plumbing fixtures uses less water with no marked reduction in quality and service
- Leak detection and repair techniques.
- Sweep with a broom and pan where possible, rather than hose down for external areas.
- Meter water usage: Implies measurement and verification methods.
- Monitoring of water uses is a precursor for management.

Horticulture

- Drip irrigation system shall be used for the lawns and other green area. Drip irrigation can save 15-40% of the water, compared with other watering techniques.
- Plants with similar water requirements shall be grouped on common zones to match precipitation heads and emitters.
- Use of low-angle sprinklers for lawn areas.

-
- Select controllers with adjustable watering schedules and moisture sensors to account for seasonal variations and calibrate them during commissioning.
 - Place 3 to 5 inches of mulch on planting beds to minimize evaporation.

Promoting Reuse of Water after Treatment and Development of Closed Loop Systems

To promote reuse of Sullage and development of closed loop system for Sullage segregation. Two water conservation schemes are suggested, namely:

- 1) Storm Water Harvest
- 2) Sullage recycling.

Storm water harvest as discussed in earlier, will be utilized for artificial recharge of ground water sources; and sullage will be reused on site after treatment.

Treated sullage will be used for landscaping; flushing and DG set cooling and rest will be used for construction purposes, following section discuss the scheme of sullage treatment.

Storm Water Management

Most of the storm water produced on site will be harvested for ground water recharge. Thus proper management of this resource is a must to ensure that it is free from contamination.

Contamination of Storm Water is possible from the following sources:

- Diesel and oil spills in the diesel power generator and fuel storage area
- Waste spills in the solid / hazardous waste storage area
- Oil spills and leaks in vehicle parking lots
- Silts from soil erosion in gardens
- Spillage of sludge from sludge drying area of sewage treatment plant

A detailed storm water management plan will be developed which will consider the possible impacts from above sources. The plan will incorporate best management practices which will include following:

- Regular inspection and cleaning of storm drains
- Clarifiers or oil/separators will be installed in all the parking areas. Oil / grease separators installed around parking areas and garages will be sized according

to peak flow guidelines. Both clarifiers and oil/water separators will be periodically pumped in order to keep discharges within limits

- Covered waste storage areas
- Avoid application of pesticides and herbicides before wet season
- Secondary containment and dykes in fuel/oil storage facilities
- Conducting routine inspection to ensure cleanliness
- Provision of slit traps in storm water drains
- Good housekeeping in the above areas

10.2.4 EMP FOR LAND ENVIRONMENT

Construction Phase

The waste generated from construction activity includes construction debris, biomass from land clearing activities, waste from the temporary make shift tents for the labors and hazardous waste. Following section discuss the management of each type of waste. Besides waste generation, management of the topsoil is an important area for which management measures are required.

Construction Debris

Construction debris is bulky and heavy and re-utilization and recycling is an important strategy for management of such waste. As concrete and masonry constitute the majority of waste generated, recycling of this waste by conversion to aggregate can offer benefits of reduced landfill space and reduced extraction of raw material for new construction activity. This is particularly applicable to the project site as the construction is to be completed in a phased manner.

Mixed debris with high gypsum, plaster, shall not be used as fill, as they are highly susceptible to contamination, and will be send to designated solid waste landfill site.

Metal scrap from structural steel, piping, concrete reinforcement and sheet metal work shall be removed from the site by construction contractors. A significant portion of

wood scrap will be reused on site. Recyclable wastes such as plastics, glass fiber insulation, roofing etc shall be sold to recyclers.

Hazardous waste

Construction sites are sources of many toxic substances such as paints, solvents wood preservatives, pesticides, adhesives and sealants. Hazardous waste generated during construction phase shall be stored in sealed containers and disposed off as per The Hazardous Wastes (Management, Handling & Transboundary Movement) Rules, 2008.

Some management practices to be developed are:

- Herbicides and pesticide will not be over applied (small-scale applications) and not applied prior to rain
- Paintbrushes and equipment for water and oil based paints shall be cleaned within a contained area and will not be allowed to contaminate site soils, water courses or drainage systems
- Provision of adequate hazardous waste storage facilities. Hazardous waste collection containers will be located as per safety norms and designated hazardous waste storage areas will be away from storm drains or watercourses
- Segregation of potentially hazardous waste from non-hazardous construction site debris
- Well labeled all hazardous waste containers with the waste being stored and the date of generation
- Instruct employees and subcontractors in identification of hazardous and solid waste

Even with careful management, some of these substances are released into air, soil and water and many are hazardous to workers. With these reasons, the best choice is to avoid their use as much as possible by using low-toxicity substitutes and low VOC (Volatile Organic Compound) materials.

Waste from Temporary Makes Shift Tents for Labors

Wastes generated from temporary make shift labor tents will mainly comprise of household domestic waste, which will be managed by the contractor of the site. The sullage generated will be channelized to the septic tank.

Top Soil Management

To minimize disruption of soil and for conservation of top soil, the contractor shall keep the top soil cover separately and stockpile it. After the construction activity is over, top soil will be utilized for landscaping activity. Other measures, which would be followed to prevent soil erosion and contamination include:

- Maximize use of organic fertilizer for landscaping and green belt development
- To prevent soil contamination by oil/grease, leaf proof containers would be used for storage and transportation of oil/grease and wash off from the oil/grease handling area shall be drained through impervious drains and treated appropriately before disposal
- Removal of as little vegetation as possible during the development and re-vegetation of bare areas after the project.
- Working in a small area at a point of time (phase wise construction)
- Construction of erosion prevention troughs/berms.

Operational Phase

The philosophy of solid waste management at the project will be to encouraging the four R's of waste i.e. **Reduction, Reuse, Recycling and Recovery** (materials & energy). Regular public awareness meetings will be conducted to involve the residents in the proper segregation and storage techniques. The Environmental Management Plan for the solid waste focuses on three major components during the life cycle of the waste management system i.e., collection and transportation, treatment or disposal and closure and post-closure care of treatment/disposal facility.

Collection and Transportation

- During the collection stage, the solid waste of the project will be segregated into biodegradable waste and non-biodegradable. Biodegradable waste and non biodegradable waste will be collected in separate bins. Biodegradable waste will be treated in the project premises by organic waste converter. The recyclable wastes will be sent off to recyclabers. Proper guidelines for segregation, collection and storage will be prepared as per MSW Rules, 2000 and amended Rules, 2008.
- To minimize littering and odour, waste will be stored in well-designed containers/ bins that will be located at strategic locations to minimize disturbance in traffic flow
- Care would be taken such that the collection vehicles are well maintained and generate minimum noise and emissions. During transportation of the waste, it will be covered to avoid littering.

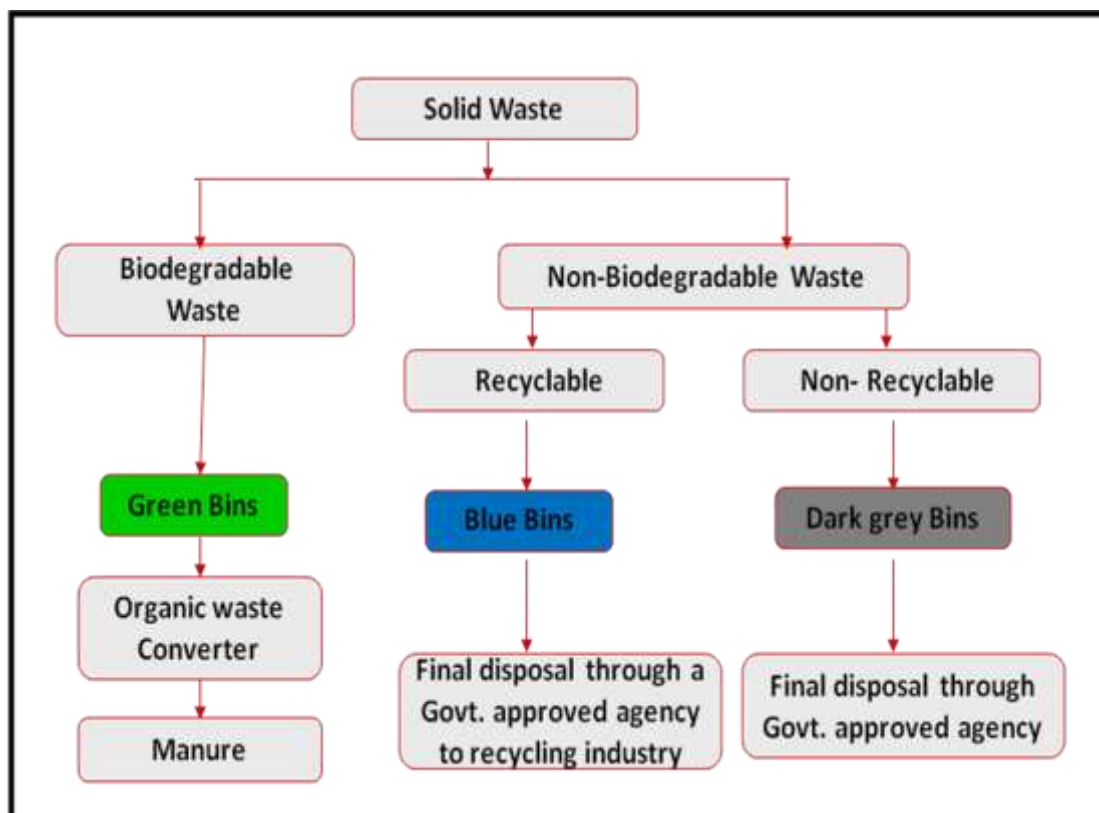

Figure 7: Waste Management Flow Diagram

Disposal

With regards to the disposal/treatment of waste, the management will take the services of the authorized agency for waste management and disposal of the same on the project site during its operational phase.

10.2.5 EMP FOR ECOLOGICAL ENVIRONMENT

Construction activity changes the natural environment. But project also creates a built environment for its inhabitants. The project requires the implementation of following choices exclusively or in combination.

Construction Stage

- Restriction of construction activities to defined project areas, which are ecologically sensitive
- Restrictions on location of temporary labor tents and offices for project staff near the project area to avoid human induced secondary additional impacts on the flora and fauna species
- Cutting, uprooting, coppicing of trees or small trees if present in and around the project site for cooking, burning or heating purposes by the labors will be prohibited and suitable alternatives for this purpose will be made
- Along with the construction work, the peripheral green belt would be developed with suggested native plant species, as they will grow to a full-fledged covered at the time of completion.

Operation Stage

Improvement of the current ecology of the project site will entail the following measures:

- Plantation and Landscaping
- Green Belt Development
- Park and Avenue Plantation

The section below summarizes the techniques to be applied to achieve the above objectives:

Plantation and landscaping

Selection of the plant species would be done on the basis of their adaptability to the existing geographical conditions and the vegetation composition of the forest type of the region earlier found or currently observed.

Green Belt Development Plan

The plantation matrix adopted for the green belt development includes pit of 0.3 m × 0.3 m size with a spacing of 2 m x 2 m. In addition, earth filling and manure may also be required for the proper nutritional balance and nourishment of the sapling. It is also recommended that the plantation has to be taken up randomly and the landscaping aspects could be taken into consideration.

Multi-layered plantation comprising of medium height trees (7 m to 10 m) and shrubs (5 m height) are for the green belt. In addition creepers will be planted along the boundary wall to enhance its insulation capacity.

Selection of Plant Species for Green Belt Development

The selection of plant species for the development depends on various factors such as climate, elevation and soil. The plants would exhibit the following desirable characteristics in order to be selected for plantation

1. The species should be fast growing and providing optimum penetrability
2. The species should be wind-firm and deep rooted
3. The species should form a dense canopy
4. As far as possible, the species should be indigenous and locally available
5. Species tolerance to air pollutants like SO₂ and NO₂ should be preferred
6. The species should be permeable to help create air turbulence and mixing within the belt
7. There should be no large gaps for the air to spill through

-
8. Trees with high foliage density, leaves with larger leaf area and hairy on both the surfaces
 9. Ability to withstand conditions like inundation and drought
 10. Soil improving plants (Nitrogen fixing rapidly decomposable leaf litter)
 11. Attractive appearance with good flowering and fruit bearing
 12. Bird and insect attracting tree species
 13. Sustainable green cover with minimal maintenance.

Parks and Avenue Plantation

- Parks and gardens maintained for recreational and ornamental purposes will not only improve the quality of existing ecology at the project site but also will improve the aesthetic value.
- Avenue Plantation
 1. Trees with colonial canopy with attractive flowering
 2. Trees with branching at 7 feet and above
 3. Trees with medium spreading branches to avoid obstruction to the traffic
 4. Fruit trees to be avoided because children may obstruct traffic and general movement of public

10.2.6 EMP for Socio-Economic Environment

As this is the plotted project Area development of Scheme 151(Sec B, C and D), Super Corridor developed by Indore Development Authority, the respective plots (Commercial/Residential) will be built up by the respective owner/developer of the plot. Therefore, the development of each of these plots by individual will be undertaken as per the state bye laws, under the supervision of experts. Socio-economic study will be done during detailed EIA / EMP study, after the issue of ToR letter and the report of the same will be attached in EIA/ EMP Report.

10.2.7 EMP FOR ENERGY CONSERVATION

Energy conservation program will be implemented through measures taken both on energy demand and supply.

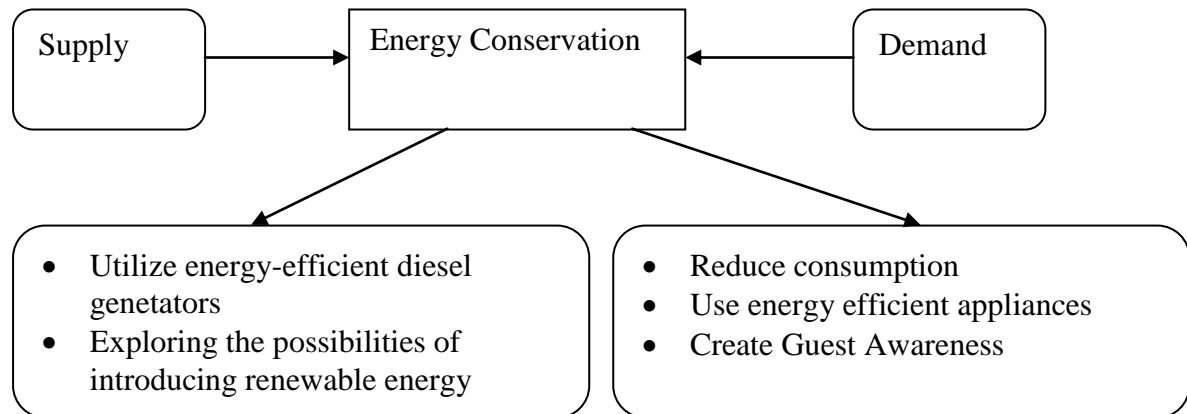

Energy conservation will be one of the main focuses during the project’s planning and operation stages. The conservation efforts would consist of the following:

Architectural design

- Maximum utilization of solar light will be done.
- Maximize the use of natural lighting through design.
- The orientation of the buildings will be done in such a way that maximum daylight is available.
- The green areas will be spaced, so that a significant reduction in the temperature can take place.

Energy Saving Practices

- Energy efficient lamps will be provided within the project.
- Constant monitoring of energy consumption and defining targets for energy conservation.
- Adjusting the settings and illumination levels to ensure minimum energy used for desired comfort levels.

Behavioral Change on Consumption

- Promoting resident awareness on energy conservation
- Training staff on methods of energy conservation and to be vigilant to such opportunities.

10.3 ENVIRONMENTAL MANAGEMENT SYSTEM AND MONITORING PLAN

For the effective and consistent functioning of the project, an Environmental Management system (EMS) would be established at the site. The EMS would include the following:

- An Environmental management cell.
- Environmental Monitoring.
- Personnel Training.
- Regular Environmental audits and Correction measures.
- Documentation – standards operation procedures Environmental Management Plan and other records.

10.3.1 ENVIRONMENTAL MANAGEMENT CELL

Apart from having an Environmental Management Plan, it is also to have a permanent organizational set up charged with the task of ensuring its effective implementation of mitigation measures and to conduct environmental monitoring. The major duties and responsibilities of Environmental Management Cell shall be as given below:

- To implement the environmental management plan.
- To assure regulatory compliance with all relevant rules and regulations.
- To ensure regular operation and maintenance of pollution control devices.
- To minimize environmental impact of operations as by strict adherence to the EMP.
- To initiate environmental monitoring as per approved schedule.

- Review and interpretation of monitored results and corrective measures in case monitored results are above the specified limit.
- Maintain documentation of good environmental practices and applicable environmental laws for a ready reference.
- Maintain environmental related records.
- Coordination with regulatory agencies, external consultants, monitoring laboratories.
- Maintenance of log of public complaints and the action taken.

Hierarchical Structure of Environmental Management Cell

Normal activities of the EMP cell would be supervised by a dedicated person who will report to the site manager/coordinator of the project. The hierarchical structure of suggested Environmental Management Cell is given in following Figure 5:

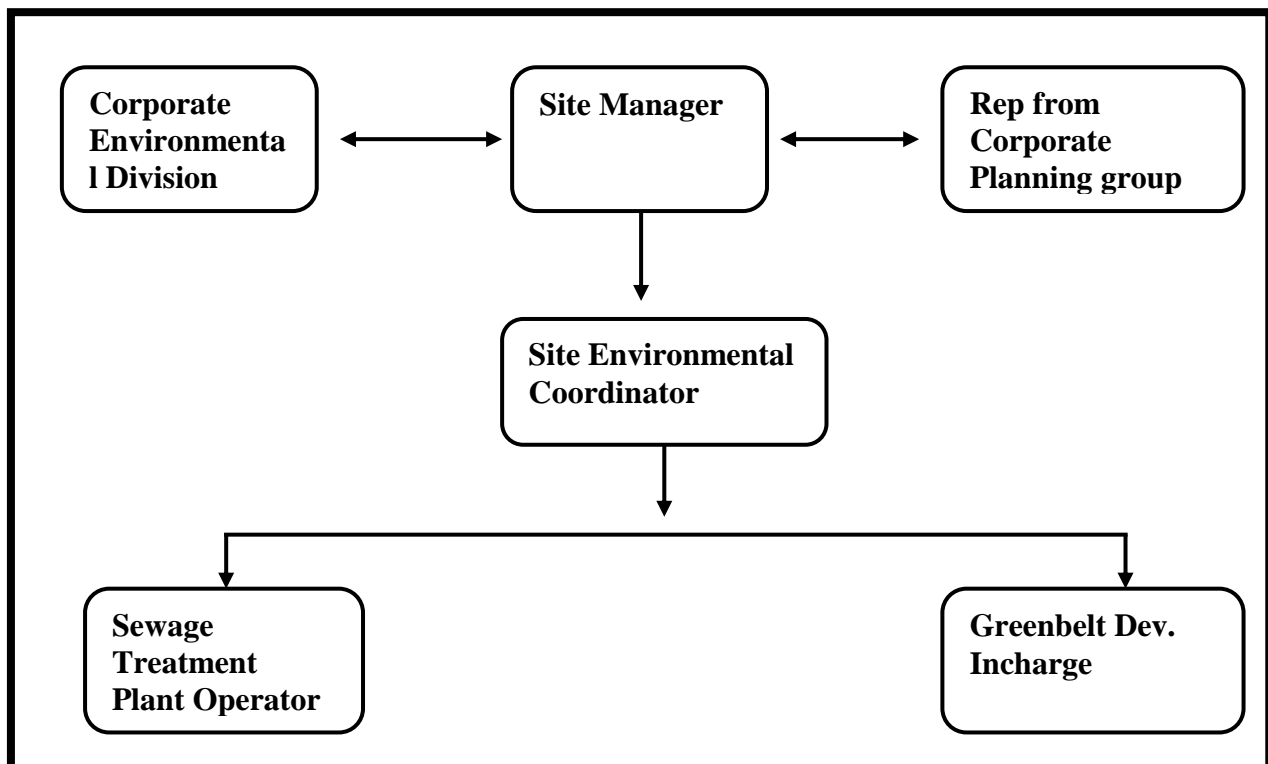

Figure 5: Environmental Management Cell Structure

10.3.2 ENVIRONMENTAL MONITORING

The purpose of environmental monitoring is to evaluate the effectiveness of implementation of Environmental Management Plan (EMP) by periodic monitoring. The important environmental parameters within the impact area are selected so that any adverse affects are detected and time action can be taken. The project proponent will monitor ambient air Quality, Ground Water Quality and Quantity, and Soil Quality in accordance with an approved monitoring schedule.

Table 14: Suggested Monitoring Program for Super Corridor

S. No.	Type	Locations	Parameters	Period and Frequency
1.	Ambient Air Quality	Project Site	Criteria Pollutants: SO ₂ , NO ₂ , PM ₁₀ , PM _{2.5} , CO	24 hr average samples every half yearly during construction phase and annual during operation phase.
3.	Ambient Noise	Project site	dB (A) levels	Hourly day and night time l_{eq} levels every half yearly during construction phase and every year during operation phase.
4.	Potable water quality	Municipal Supply	As per IS 10500 potable water standards	Half yearly
5.	Soil quality	Project site	Organic matter, C.H., N, Alkalinity, Acidity, heavy metals and trace metal, Alkalinity, Acidity.	Half yearly
6.	Waste Characterizati	Project site	Physical and Chemical	Daily

	on		composition	
7.	Treated water	Outlet of STP	BOD, MPN, coliform count, etc.	Half yearly

10.3.3 Awareness and Training

Training and human resource development is an important link to achieve sustainable operation of the facility and environment management. For successful functioning of the project, relevant EMP would be communicated to:

Residents and Contractors

Residents, visitors and staff must be made aware of the importance of waste segregation and disposal, water and energy conservation. The awareness can be provided by periodic Integrated Society meetings. They would be informed of their duties.

10.3.4 Environmental Audits and Corrective Action Plans

To assess whether the implemented EMP is adequate, periodic environmental audits will be conducted by the project proponent's Environmental division. These audits will be followed by Corrective Action Plan (CAP) to correct various issues identified during the audits.