



IL&FS | Environment

TECHNICAL EIA GUIDANCE MANUAL FOR CEMENT INDUSTRY

Prepared for
The Ministry of Environment and Forests
Government of India



by
IL&FS Ecosmart Limited
Hyderabad

August 2010

PROJECT TEAM

Project Coordination Ministry of Environment & Forests	Dr. Nalini Bhat Advisor, Ministry of Environment and Forests Dr. T. Chandni Director, Ministry of Environment and Forests
Core Project Coordination Team IL&FS Environment	Mr. Mahesh Babu CEO Mr. N. Sateesh Babu Vice President & Project Director Mr. B.S.V. Pavan Gopal Manager –Technical Mr. Padmanabhachar. K Environmental Engineer Ms. Suman Benedicta Thomas Technical Writer
Resource Person	Dr. A.K. Mullick Former Director General, National Council for Cement and Building Materials
Expert Core & Peer Committee Chairman	Dr. V. Rajagopalan, IAS Additional Secretary Ministry of Chemicals & Fertilizers
Core Members	Dr. R. K. Garg Former Chairman, EIA Committee, Ministry of Environment and Forests Mr. Paritosh C. Tyagi Former Chairman, Central Pollution Control Board Prof. S.P. Gautam Chairman, Central Pollution Control Board Dr. Tapan Chakraborti Director, National Environmental Engineering Research Institute Mr. K. P. Nyati Former Head, Environmental Policy, Confederation of Indian Industry Dr. G.K. Pandey Former Advisor, Ministry of Environment and Forests Dr. Nalini Bhat Advisor, Ministry of Environment and Forests Dr. G.V. Subramaniam Advisor, Ministry of Environment and Forests Dr. B. Sengupta Former Member Secretary, Central Pollution Control Board Dr. R. C. Trivedi Former Scientist, Central Pollution Control Board
Member Convener	Mr. N. Sateesh Babu Project Director

TABLE OF CONTENTS

1. INTRODUCTION TO THE TECHNICAL EIA GUIDANCE MANUALS PROJECT	1-1
1.1 Purpose.....	1-2
1.2 Project Implementation.....	1-4
1.3 Additional Information.....	1-4
2. CONCEPTUAL FACETS OF EIA	2-1
2.1 Environment in EIA Context.....	2-1
2.2 Pollution Control Strategies.....	2-2
2.3 Tools for Preventive Environmental Management.....	2-2
2.3.1 Tools for assessment and analysis.....	2-3
2.3.2 Tools for action.....	2-5
2.3.3 Tools for communication.....	2-10
2.4 Objectives of EIA.....	2-10
2.5 Types of EIA.....	2-11
2.6 Basic EIA Principles.....	2-12
2.7 Project Cycle.....	2-13
2.8 Environmental Impacts.....	2-13
2.8.1 Direct impacts.....	2-14
2.8.2 Indirect impacts.....	2-14
2.8.3 Cumulative impacts.....	2-15
2.8.4 Induced impact.....	2-15
2.9 Significance of Impacts.....	2-16
2.9.1 Criteria/methodology to determine the significance of the identified impacts....	2-17
3. ABOUT CEMENT PLANTS INCLUDING PROCESS AND POLLUTION CONTROL TECHNOLOGIES	3-1
3.1 Introduction.....	3-1
3.2 Scientific Aspects.....	3-4
3.2.1 Industrial process.....	3-4
3.2.2 Raw material inputs and pollution outputs in the production line.....	3-6
3.3 Technological Aspects.....	3-16
3.3.1 Natural resource conservation.....	3-16
3.4 Summary of Applicable National Regulations.....	3-28
3.4.1 General description of major statutes.....	3-28
3.4.2 General standards for discharge of environmental pollutants.....	3-28
3.4.3 Industry-specific requirements.....	3-28
3.4.4 Pending and proposed regulatory requirements.....	3-29
4. OPERATIONAL ASPECTS OF EIA	4-1
4.1 Coverage of Cement Plants under the Purview of Notification.....	4-1
4.2 Screening.....	4-5

4.2.1	Applicable conditions for Category B projects	4-5
4.2.2	Criteria for classification of Category B1 and B2 projects.....	4-5
4.2.3	Application for prior environmental clearance.....	4-6
4.2.4	Siting guidelines	4-6
4.3	Scoping for EIA Studies.....	4-7
4.3.1	Pre-feasibility report.....	4-9
4.3.2	Guidance for providing information in Form 1	4-9
4.3.3	Identification of appropriate valued environmental components	4-9
4.3.4	Methods for identification of impacts.....	4-10
4.3.5	Testing the Significance of Impacts	4-15
4.3.6	Terms of reference for EIA studies	4-15
4.4	Environmental Impact Assessment	4-20
4.4.1	EIA team.....	4-21
4.4.2	Baseline quality of the environment.....	4-21
4.4.3	Impact prediction tools	4-24
4.4.4	Significance of the impacts.....	4-24
4.5	Social Impact Assessment.....	4-25
4.6	Risk Assessment.....	4-28
4.7	Mitigation Measures.....	4-32
4.7.1	Important considerations for mitigation methods.....	4-32
4.7.2	Hierarchy of elements of mitigation plan	4-33
4.7.3	Typical mitigation measures.....	4-34
4.8	Environmental Management Plan	4-38
4.8.1	Monitoring requirement.....	4-39
4.9	Reporting.....	4-40
4.10	Public Consultation	4-42
4.11	Appraisal	4-45
4.12	Decision Making	4-46
4.13	Post-clearance Monitoring Protocol.....	4-48
5.	STAKEHOLDERS' ROLES AND RESPONSIBILITIES	5-1
5.1	SEIAA	5-4
5.2	EAC and SEAC	5-6

LIST OF TABLES

Table 3-1: Indian Cement Industry (April 2008)	3-2
Table 3-2: Total Cement Production from 2006-08.....	3-3
Table 3-3: Raw Material Consumption of Cement	3-7
Table 3-4: Thermal and Electrical Consumption in Dry Process Cement Plants in India	3-8
Table 3-5: Specific Thermal Energy Consumption in Indian Cement Sector.....	3-8
Table 3-6: Specific Electric Energy Consumption (kWh/t of Material)	3-8
Table 3-7: Sources of Fugitive Dust Emission	3-11
Table 3-8: PM Emission Factors with and without APCD for Cement Manufacturing Industries in India (Dry Type)	3-11
Table 3-9: PM Emission factors with and without APCD for Cement Manufacturing Industries in India (Wet Process).....	3-12
Table 3-10: NOx Emission Factors and Concentrations	3-12
Table 3-11: SO ₂ Emission Factors and Concentrations	3-13
Table 3-12: Industrial Wastes Suitable for Use as Raw Material	3-16
Table 3-13: Industrial Wastes Suitable for Use as Blending Material.....	3-17
Table 3-14: Waste Derived Fuels Suitable in Cement Manufacture.....	3-18
Table 3-15: Recommended Dust Control Equipments for Different Sectors	3-21
Table 3-16: Salient Features of Dust Collectors	3-22
Table 3-17: Methods of Fugitive Dust Control.....	3-22
Table 3-18: NOx and SOx Emissions Limits for Cement Industry in force	3-29
Table 4-1: Advantages and Disadvantages of Impact Identification Methods	4-10

Table of Contents

Table 4-2: Matrix of Impacts 4-12

Table 4-3: List of Important Physical Environment Components and Indicators of EBM..... 4-22

Table 4-4: Choice of Models for Impact Predictions: Risk Assessment..... 4-29

Table 4-5: Typical Mitigation Measures..... 4-35

Table 4-6: Structure of EIA Report..... 4-40

Table 5-1: Roles and Responsibilities of Stakeholders Involved in Prior Environmental Clearance 5-1

Table 5-2: Organization-specific Functions..... 5-2

Table 5-3: SEIAA: Eligibility Criteria for Chairperson/ Members/ Secretary 5-5

Table 5-4: EAC/SEAC: Eligibility Criteria for Chairperson / Members / Secretary 5-9

LIST OF FIGURES

Figure 2-1: Inclusive Components of Sustainable Development.....	2-1
Figure 2-2: Types of Impacts	2-14
Figure 2-3: Cumulative Impact.....	2-15
Figure 3-1: Growth of Cement Production in India.....	3-1
Figure 3-2: Yearly Production of Three Major Types of Cement	3-3
Figure 3-3: Cement Manufacturing Process (dry SP/PC Kiln).....	3-5
Figure 3-4: Cement Manufacturing Process – Inputs and Outputs	3-6
Figure 3-5: Point Sources from a Cement Manufacturing Process.....	3-10
Figure 4-1: Prior Environmental Clearance Process for Activities Falling Under Category A.....	4-3
Figure 4-2: Prior Environmental Clearance Process for Activities Falling Under Category B	4-4
Figure 4-3: Approach for EIA Study	4-20
Figure 4-4: Risk Assessment – Conceptual Framework.....	4-29
Figure 4-5: Comprehensive Risk Assessment - At a Glance	4-31
Figure 4-6: Elements of Mitigation.....	4-33

LIST OF ANNEXURES

Annexure I

Environmental Guidelines for Control of Fugitive Emissions from Cement Plant

Annexure II

A Compilation of Legal Instruments

Annexure III

General Standards for Discharge of Environmental Pollutants

Annexure IV

Form 1 (Application Form for Obtaining EIA Clearance)

Annexure V

List of Critically Polluted Areas

Annexure VI

Pre-Feasibility Report: Points for Possible Coverage

Annexure VII

Types of Monitoring and Network Design Considerations

Annexure VIII

Guidance for Assessment of Baseline Components and Attributes

Annexure IX

Sources of Secondary Data

Annexure X

Impact Prediction Tools

Annexure XI

Form through which the State Government/Administration of the Union Territories Submit Nominations for SEIAA and SEAC for the Consideration and Notification by the Central Government.

Annexure XII

Composition of EAC/SEAC

Annexure XIII

Best Practices & Latest Technologies available and reference

ACRONYMS

AAQ	Ambient Air Quality
APCD	Air Pollution Control Devices
B/C	Benefits Cost Ratio
CAGR	Compound Annual Growth Rate
CCA	Conventional Cost Accounting
CEAA	Canadian Environmental Assessment Agency
CMA	Cement Manufacturers' Association
CPCB	Central Pollution Control Board
CREP	Corporate Responsibility for Environmental Protection
ECI	Environmental Condition Indicators
EIA	Environmental Impact Assessment
EIS	Environmental Information System
EMP	Environmental Management Plan
EMS	Environmental Management System
EPI	Environmental Performance indicators
EPZ	Export Processing Zones
ESP	Electrostatic Precipitators
FCA	Full Cost Assessment
GHG	Green House Gases
HCW	Hazardous Combustible Wastes
IL&FS	Infrastructure Leasing and Financial Services
ISO	International Standard Organization
LDAR	Leak Detection and Repair
LCA	Life Cycle Assessment
LTL	Low Tide Level
MFA	Material Flow Accounting
MoEF	Ministry of Environment & Forests
NAQM	National Air Quality Monitoring
NCB	National Council for Cement and Building Materials
NGO	Non-Government Organizations
O&M	Operation and Maintenance
OPC	Ordinary Portland Cement
PBFS	Portland Blast Furnace Slag Cement
PCDDs	Polychlorinated dibenzodioxins
PCDFs	Polychlorinated dibenzofurans
PH	Preheater

PHP	Preheater-precalsiner
PM	Particulate Matter
PPC	Portland Pozzolana Cement
PSC	Portland Slag Cement
PSD	Particle Size Distribution
QA/QC	Quality Assurance/Quality Control
QRA	Quantitative Risk Assessment
SAR	Sodium Absorption Ratio
SCR	Selective Catalytic Reduction
SEAC	State Level Expert Appraisal Committee
SEIAA	State Level Environment Impact Assessment Authority
SPCB	State Pollution Control Board
SPM	Suspended Particulate Matter
SSI	Small-Scale Industries
TA	Technology Assessment
TCA	Total Cost Assessment
TGM	Technical EIA Guidance Manual
UTEIAA	Union Territory Environment Impact Assessment Authority
UTPCC	Union Territory Pollution Control Committee
VOC	Volatile Organic Compound
VRM	Vertical Roller Mills
WDF	Waste Derived Fuels

1. INTRODUCTION TO THE TECHNICAL EIA GUIDANCE MANUALS PROJECT

Environmental Impact Assessment (EIA) is a process of identifying, predicting, evaluating and mitigating the biophysical, social, and other relevant effects of development proposals prior to major decisions being taken and commitments made. These studies integrate the environmental concerns of developmental activities into the process of decision-making.

EIA has emerged as one of the successful policy innovations of the 20th Century in the process of ensuring sustained development. Today, EIA is formalized as a regulatory tool in more than 100 countries for effective integration of environmental concerns in the economic development process. The EIA process in India was made mandatory and was also given a legislative status through a Notification issued by the Ministry of Environment and Forests (MoEF) in January 1994. The Notification, however, covered only a few selected industrial developmental activities. While there are subsequent amendments, the Notification issued on September 14, 2006 supersedes all the earlier Notifications, and has brought out structural changes in the clearance mechanism.

The basic tenets of this EIA Notification could be summarized into the following:

- Pollution potential as the basis for prior environmental clearance instead of investment criteria; and
- Decentralization of clearing powers to the State/Union Territory (UT) level Authorities for certain developmental activities to make the prior environmental clearance process quicker, transparent and effective.

Devolution of the power to grant clearances at the state level for certain category of the developmental activities / projects is a step forward to fulfill the basic tenets of the re-engineering *i.e.*, quicker, transparent and effective process but many issues impede/hinder its functional efficiency. These issues could be in technical and operational as listed below:

Technical issues

- Ensuring level playing ground to avoid arbitrariness in the decision-making process
- Classification of projects which do not require public hearing and detailed EIA (Category B2)
- Variations in drawing Terms of Reference (ToR) of EIA studies for a given developmental activity across the States/UTs
- Varying developmental-activity-specific expertise requirement for conducting EIA studies and their appraisal
- Availability of adequate sectoral experts and variations in competency levels
- Inadequate data verification, cross checking tools and supporting institutional framework

- Meeting time targets without compromising with the quality of assessments/ reviews
- Varying knowledge and skill levels of regulators, consultants and experts
- Newly added developmental activities for prior environmental clearance, *etc.*

Operational issues

- State level /UT level EIA Authorities (SEIAA/UTEIAA) are formulated for the first time and many are functioning
- Varying roles and responsibilities of involved organizations
- Varying supporting institutional strengths across the States/UTs
- Varying manpower availability, *etc.*

1.1 Purpose

The purpose of developing the sector-specific technical EIA guidance manuals (TGM) is to provide clear and concise information on EIA to all the stakeholders i.e., the project proponent, the consultant, the reviewer, and the public. The TGMs are organized to cover following:

Chapter 1 (Introduction): This chapter provides a brief introduction on the EIA, basic tenets of EIA Notification, technical & operational issues in the process of clearance, purpose of the TGMs, project implementation process and additional information.

Chapter 2 (Conceptual facets of an EIA): Provides an overall understanding to the conceptual aspects of control of pollution and EIA for the developmental projects. This basic understanding would set the readers at same level of understanding for proper interpretations and boundaries for identifying the environmental interactions of the developmental projects and their significance for taking mitigative measures. This chapter covers the discussion on environment in EIA context *i.e* sustainable development, pollution control strategies, preventive environmental management tools, Objectives of EIA, types and basic principles of EIA, project cycle for cement industry, understanding on type of environmental impacts and the criteria for the significance analysis.

Chapter 3 (Cement Industry): The purpose of this chapter is to provide the reader precise information on all the relevant aspects of the industry, which is essential to realize the likely interaction of such developmental activities on the receiving environment. Besides, this Chapter gives a holistic understanding on the sources of pollution and the opportunities of the source control.

The specific coverage which provides precise information on the industry include (i) introduction, (ii) Scientific aspects- industrial process, Raw material inputs and pollution outputs in the production line, (iii) Technological Aspects- Natural resource conservation, and (iv) Summary of Applicable National Regulations - General description of major statutes, General standards for discharge of environmental pollutants, Industry-specific requirements, Pending and proposed regulatory requirements.

Chapter 4 (Operational aspects): The purpose of this chapter is to facilitate the stakeholders to extend clear guidance on coverage of legislative requirements, sequence of procedures for obtaining the EIA clearance and each step-wise provisions and considerations.

The coverage of the Chapter include provisions in the EIA Notification regarding proposed industry, screening (criteria for categorization of B1 and B2, siting guidelines, *etc.*), scoping (pre-feasibility report, guidance for filling form 1, identification of valued environmental components, identification of impacts, *etc.*), arriving at terms of reference for EIA studies, impact assessment studies (EIA team, assessment of baseline quality of environment, impact prediction tools, significance of impacts), social impact assessment, risk assessment considerations, typical mitigation measures, designing considerations for environmental management plan, structure of EIA report for incorporation of study findings, process of public consultation, project appraisal, decision making process and post-clearance monitoring protocol.

Chapter 5 (Roles and responsibilities of various organizations involved in the process of prior environmental clearance): The purpose of this Chapter is to brief the stakeholders on the institutional mechanism and roles & responsibilities of the stakeholders involved in the process of prior environmental clearance. The Coverage of the Chapter include (i) roles and responsibilities of the stakeholders, (ii) organization specific functions, (iii) constitution, composition and decision making process of SEIAA and (iv) EAC & SEAC and (v) other conditions which may be considered

For any given industry, each topic listed above could alone be the subject of a lengthy volume. However, in order to produce a manageable document, this project focuses on providing summary information for each topic. This format provides the reader with a synopsis of each issue. Text within each section was researched from many sources, and was condensed from more detailed sources pertaining to specific topics.

The contents of the document are designed with a view to facilitate addressing of relevant technical and operational issues as mentioned in the earlier section. Besides, it also facilitates various stakeholders involved in the EIA clearance process *i.e.*,

- Project proponents will be fully aware of the procedures, common ToR for EIA studies, timelines, monitoring needs, *etc.*, in order to plan the projects/studies appropriately
- Consultants across India will gain similar understanding about a given sector, and also the procedure for EIA studies, so that the quality of the EIA reports gets improved and streamlined
- Reviewers across the States/UTs will have the same understanding about an industrial sector and would able to draw a benchmark in establishing the significant impacts for the purpose of prescribing the ToR for EIA studies and also in the process of review and appraisal
- Public who are concerned about new or expansion projects, use this manual to get a basic idea about the manufacturing/production details, rejects/wastes from the operations, choice of cleaner/control technologies, regulatory requirements, likely environmental and social concerns, mitigation measures, *etc.*, in order to seek clarifications appropriately in the process of public consultation. The procedural clarity in the document will further strengthen them to understand the stages involved in clearance and roles and responsibilities of various organizations
- In addition, these manuals would substantially ease the pressure on reviewers at the scoping stage and would bring in functional efficiency at the central and state levels

1.2 Project Implementation

The Ministry of Environment & Forests (MoEF), Government of India took up the task of developing sector-specific TGMs for all the developmental activities listed in the re-engineered EIA Notification. The Infrastructure Leasing and Financial Services Ecosmart Limited (IL&FS Ecosmart), has been entrusted with the task of developing these manuals for 27 industrial and related sectors. Cement industry is one of these sectors, for which this manual is prepared.

The ability to design comprehensive EIA studies for specific industries depends on the knowledge of several interrelated topics. Therefore, it requires expert inputs from multiple dimensions *i.e.*, administrative, project management, technical, scientific, social, economic, risk *etc.*, in order to comprehensively analyze the issues of concern and to draw logical interpretations. Thus, Ecosmart has designed a well-composed implementation framework to factor inputs of the experts and stakeholders in the process of finalization of these manuals.

The process of manual preparation involved collection & collation of the secondary available information, technical review by sectoral resource persons and critical review & finalization by a competent Expert Committee composed of core and sectoral peer members.

The MoEF appreciates the efforts of Ecosmart, Expert Core and Peer Committee, resource persons and all those who have directly and indirectly contributed to this Manual.

1.3 Additional Information

This TGM is brought out by the MoEF to provide clarity to all the stakeholders involved in the 'Prior Environmental Clearance' process. As such, the contents and clarifications given in this document do not withstand in case of a conflict with the statutory provisions of the Notifications and Executive Orders issued by the MoEF from time-to-time.

TGMs are not regulatory documents. Instead these are the tools designed to assist in successful completion of an EIA.

For the purpose of this project, the key elements considered under TGMs are: conceptual aspects of EIA; developmental activity-specific information; operational aspects; and roles and responsibilities of involved stakeholders.

This manual is prepared considering the Notification issued on 14th September, 2006 and its latest amendment as on 1st December, 2009. For recent updations, if any, may please refer the website of the MoEF, Government of India *i.e.*, <http://moef.nic.in/index.php>.

2.

CONCEPTUAL FACETS OF EIA

It is an imperative requirement to understand the basic concepts concerned to the pollution control and the environmental impact assessment in an overall objective of the sustainable development. This Chapter highlights the pollution control strategies and their tools besides the objectives, types & principles of EIA, type of impacts their significance analysis, in order to provide consistent understanding to the reader before assessing the development of activity-specific environmental concerns in Chapter 3 and identification & prediction of significant impacts in order to design mitigation measures as detailed in Chapter 4.

2.1 Environment in EIA Context

“Environment” in EIA context mainly focuses, but is not limited to physical, chemical, biological, geological, social, economical, and aesthetic dimensions along with their complex interactions, which affect individuals, communities and ultimately determines their forms, character, relationship, and survival. In EIA context, ‘effect’ and ‘impact’ can often be used interchangeably. However, ‘impact’ is considered as a value judgment of the significance of an effect.

Sustainable development is built on three basic premises *i.e.*, economic growth, ecological balance and social progress. Economic growth achieved in a way that does not consider the environmental concerns, will not be sustainable in the long run. Therefore, sustainable development needs careful integration of environmental, economic, and social needs in order to achieve both an increased standard of living in short term, and a net gain or equilibrium among human, natural, and economic resources to support future generations in the long term.

“It is necessary to understand the links between environment and development in order to make choices for development that will be economically efficient, socially equitable and responsible, as well as environmentally sound.” Agenda 21

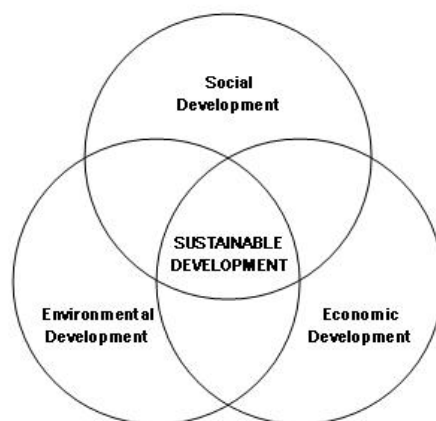

Figure 2-1: Inclusive Components of Sustainable Development

2.2 Pollution Control Strategies

Pollution control strategies can be broadly categorized in to preventive and reactive. The reactive strategy refers to the steps that may be applied once the wastes are generated or contamination of the receiving environment takes place. The control technology or a combination of technologies to minimize the impact due to the process rejects/wastes varies with quantity and characteristics, desired control efficiency and economics.

Many combinations of techniques could be adopted for treatment of a specific waste or the contaminated receiving environment, but are often judged based on techno-economic feasibility. Therefore, the best alternative is to take all possible steps to avoid pollution itself. This preventive approach refers to a hierarchy that involves i) prevention & reduction; ii) recycling and re-use; iii) treatment; and iv) disposal, respectively.

Therefore, there is a need to shift the emphasis from the reactive to preventive strategy *i.e.*, to promote preventive environmental management. Preventive environmental management tools may be grouped into management based tools, process based tools and product based tools. A few of them are given below ;

Management Based Tools	Process Based Tools	Product Based Tools
Environmental Management System (EMS)	Environmental Technology Assessment	Industrial Ecology
Environmental Performance Evaluation	Toxic Use Reduction	Extended Producers Responsibility
Environmental Audits	Best Operating Practices	Eco-labeling
Environmental Reporting and Communication	Environmentally Best Practice	Design for Environment
Total Cost Accounting	Best Available Technology (BAT)	Life Cycle Assessment (LCA)
Law and Policy	Waste Minimization	
Trade and Environment	Pollution Prevention	
Environmental Economics	Cleaner Production	
	4-R concept	
	Cleaner Technology	
	Eco-efficiency	

2.3 Tools for Preventive Environmental Management

The tools for preventive environmental management can be broadly classified into following three groups.

- Tools for assessment and analysis - risk assessment, life cycle assessment, total cost assessment, environmental audit / statement, environmental benchmarking, environmental indicators
- Tools for action - environmental policy, market based economic instruments, innovative funding mechanism, EMS and ISO certification, total environmental quality movement, eco-labeling, cleaner production, eco-efficiency, industrial ecosystem or metabolism, voluntary agreements
- Tools for communication - state of environment, corporate environmental reporting

Specific tools under each group are discussed precisely in next sections.

2.3.1 Tools for assessment and analysis

2.3.1.1 Risk assessment

Risk is associated with the frequency of failure and consequence effect. Predicting such situations and evaluation of risk is essential to take appropriate preventive measures. The major concern of the assessment is to identify the activities falling in a matrix of high & low frequencies at which the failures occur and the degree of its impact. The high frequency, low impact activities can be managed by regular maintenance *i.e.*, LDAR (Leak detection and repair) programmes. Whereas, the low frequency, high impact activities (accidents) are of major concern in terms of risk assessment. As the frequency is low, often the required precautions are not realized or maintained. However, the risk assessment identifies the areas of major concerns which require additional preventive measures; likely consequence distances considering domino effects, which will give the possible casualties and ecological loss in case of accidents. These magnitudes demand the attention for preventive and disaster management plans (DMP). Thus is an essential tool to ensure safety of operations.

2.3.1.2 Life cycle assessment

A broader approach followed to deal with environmental impacts during manufacturing is called LCA. This approach recognizes that environmental concerns are associated with every step of the processing w.r.t. manufacturing of products and also examines environmental impacts of the product at all stages of project life cycle. LCA includes the product design, development, manufacturing, packaging, distribution, usage and disposal. LCA is concerned with reducing environmental impacts at all stages and considering the total picture rather than just one stage of the production process.

Industries/ firms may apply this concept to minimize costs incurred on the environmental conservation throughout the project life cycle.

2.3.1.3 Total cost assessment

Total Cost Assessment (TCA) is an enhanced financial analysis tool that is used to assess the profitability of alternative courses of action *ex.* raw material substitution to reduce the costs of managing the wastes generated by process; an energy retrofit to reduce the costs of energy consumption. This is particularly relevant for pollution prevention options. These options because of their nature, often produce financial savings that are overlooked in conventional financial analysis, either because they are misallocated, uncertain, hard to quantify, or occur more than three to five years after the initial investment. TCA includes all relevant costs and savings associated with an option so that it can compete for scarce capital resources fairly, on a level playing field. The assessments are often beneficial w.r.t the following:

- Identification of costly resource inefficiencies
- Financial analysis of environmental activities/projects such as investment in cleaner technologies
- Prioritization of environmental activities/projects
- Evaluation of product mix and product pricing
- Bench marking against the performance of other processes or against the competitors

A comparison of cost assessments is given below:

- Conventional cost accounting (CCA): Direct and indirect financial costs+ Recognized contingent costs
- Total Cost Assessment (TCA): A broader range of direct, indirect, contingent and less quantifiable costs
- Full Cost assessment (FCA): TCA + External social costs borne by society

2.3.1.4 Environmental audit/statement

Key objectives of an environmental audit include compliance verification, problem identification, environmental impact measurement, environmental performance measurement, conforming effectiveness of EMS, providing a database for corrective actions and future actions, developing companies environmental strategy, communication and formulating environmental policy.

The MoEF, Government of India (GoI) issued Notification on ‘*Environmental Statements*’ (ES) in April, 1992 and further amended in April 1993. As per the Notification, the industries are required to submit environmental statements to the respective State Pollution Control Board (SPCB). ES is a pro-active tool for self-examination of the industry to reduce/minimize pollution by adopting process modifications, recycling and reusing of the resources. The regular submission of ES will indicate the systematic improvement in environmental pollution control being achieved by the industry. In other way, specific points in ES may be used as environmental performance indicators for relative comparison, implementation and to promote better practices.

2.3.1.5 Environmental benchmarking

Environmental performance and operational indicators could be used to navigate, manage and communicate significant aspects and give enough evidence of good environmental house keeping. Besides the existing prescribed standards, an insight to identify the performance indicators and prescribing schedule for systematic improvement in performance of these indicators will yield better results.

Relative indicators may be identified for different industrial sectors and be integrated in companies and organizations to monitor and manage the different environmental aspects of the company, to benchmark and compare two or more companies from the same sector. These could cover water consumption, wastewater generation, energy consumption, solid/hazardous waste generation, chemical consumption *etc.*, per tonne of final product. Once these bench marks are developed, the industries which are below them may be guided and enforced to reach them while those which are better than the benchmark may be encouraged further by giving incentives *etc.*

2.3.1.6 Environmental indicators

Indicators can be classified in to environmental performance indicators (EPI) and environmental condition indicators (ECI). The EPIs can be further divided into two categories *i.e.*, operational performance indicators and management performance indicators.

The operational performance indicators are related to the process and other operational activities of the organization. These would typically address the issue of raw material consumption, energy consumption, water consumption in the organization, the quantities

of wastewater generated, other solid wastes & emissions generated from the organization *etc.*

Management performance indicators are related to management efforts to influence environmental performance of organizational operations.

The environmental condition indicators provide information about the environment. These indicators provide information about the local, regional, national or global condition of the environment. This information helps an organization to understand the environmental impacts of its activities and thus helps in taking decisions to improve the environmental performance.

Indicators basically used to evaluate environmental performance against the set standards and thus indicate the direction in which to proceed. Selection of type of indicators for a firm or project depends upon its relevance, clarity and realistic cost of collection and its development.

2.3.2 Tools for action

2.3.2.1 Environmental policy

An environmental policy is a statement of an organization's overall aim and principles of action w.r.t the environment, including compliance with all relevant regulatory requirements. It is a key tool in communicating environmental priorities of the organizations to all its employees. To ensure organization's commitment towards a formulated environmental policy, it is essential for the top management to be involved in the process of formulating the policy and setting priorities. Therefore, the first step is to get the commitment from the higher levels of management. The organization should then conduct an initial environmental review and draft an environmental policy. This draft should be discussed and approved by the board of directors. The approved environmental policy statement should then be communicated internally among all its employees and should also be made available to the public.

2.3.2.2 Market-based economic instruments

Market based instruments are regulations that encourage behavior through market signals rather than through explicit directives regarding pollution control levels. These policy instruments such as tradable permits, pollution charge, *etc.*, are often described as harnessing market forces. Market based instruments can be categorized into the following four major categories, which are discussed below:

- **Pollution charge:** Charge system will assess a fee or tax on the amount of pollution a firm or source generates. It is worthwhile for the firm to reduce emissions to the point, where its marginal abatement cost is equal to the tax rate. Thus firms control pollution to different degrees *i.e.* high cost controllers – less; low-cost controllers – more. The charge system encourages the industries to reduce the pollutants further. The collected charges can form a fund for restoration of the environment. Another form of pollution charge is a deposit refund system, where consumers pay a surcharge when purchasing a potentially polluting product, and receive a refund on return of the product after useful life span at appropriate centers. The concept of extended producers' responsibility brought in to avoid accumulation of dangerous products in the environment.

- **Tradable permits:** Under this system, firms that achieve the emission levels below their allotted level may sell the surplus permits. Similarly, the firms, which are required to spend more to attain the required degree of treatment/allotted levels, can purchase permits from others at lower costs and may be benefited.
- **Market barrier reductions:** Three known market barrier reduction types are as follows:
 - Market Creation: Measures that facilitate the voluntary exchange of water rights and thus promote more efficient allocation of scarce water supplies
 - Liability Concerns: Encourage firms to consider potential environmental damages of their decisions
 - Information Programmes: Eco-labeling and energy- efficiency product labeling requirements
- **Government subsidy reduction:** Subsidies are the mirror images of taxes and, in theory, can provide incentive to address environmental problems. However, it has been reported that the subsidies encourage economically inefficient and environmentally unsound practices, and often leads to market distortions due to differences in the area. However, these are important to sustain the expansion of production, in the national interests. In such cases, the subsidy may be comparable to the net social benefit.

2.3.2.3 Innovative funding mechanism

There are many forums under which the fund is made available for the issues which are of global/regional concern *i.e.*, climate change, Basal Convention and further fund sources are being explored for the Persistent Organic Pollutants Convention. Besides the global funding mechanism, there needs to be localized alternative mechanisms for boosting the investment in environmental pollution control. For example, in India the Government has established mechanism to fund the common effluent treatment plants, which are specifically serving the small and medium scale enterprises *i.e.*, 25% share by the State Government, matching grants from the Central Government and surety for 25% soft loan. It means that the industries need to invest only 25% initially, thus encouraging voluntary compliance.

There are some more options *i.e.*, if the pollution tax/charge is imposed on the residual pollution being caused by the industries, municipalities *etc.*, fund will automatically be generated, which in turn, can be utilized for funding the environmental improvement programmes. The emerging concept of build-operate-transfer (BOT) is an encouraging development, where there is a possibility to generate revenue by application of advanced technologies. There are many opportunities which can be explored. However, what is required is the paradigm shift and focused efforts.

2.3.2.4 EMS and ISO certification

EMS is that part of the overall management system, which includes the organizational structure, responsibilities, practices, procedures, process and resources for determining and implementing the forms of overall aims, principles of action w.r.t the environment. It encompasses the totality of organizational, administrative and policy provisions to be taken by a firm to control its environmental influences. Common elements of an EMS are the identification of the environmental impacts and legal obligations, the development of

a plan for management & improvement, the assignment of the responsibilities and monitoring of the performance.

2.3.2.5 Total environmental quality movement (TEQM)

Quality is regarded as

- A product attribute that had to be set at an acceptable level and balanced against the cost
- Something delivered by technical systems engineered by experts rather than the organization as a whole
- Assured primarily through the findings and correction of mistakes at the end of the production process

One expression of the total environment quality movement (TEQM) is a system of control called Kaizen. The principles of Kaizen are

- Goal must be continuous improvement of quality instead of acceptable quality
- Responsibility of quality shall be shared by all members of an organization
- Efforts should be focused on improving the whole process and design of products

With some modifications, TEQM approach can be applied in improvement of corporate environmental performance in both process and product areas.

2.3.2.6 Eco-labeling

Eco-labeling is the practice of supplying information on the environmental characteristics of a product or service to the general public. These labeling schemes can be grouped into three types:

- Type I: Multiple criteria base; third party (Govt. or non-commercial private organizations) programme claims overall environmental preferability
- Type II: Specific attribute of a product; often issued by a company/industrial association
- Type III: Agreed set of indices; provide quantified information; self declaration

Among the above, Type I are more reliable because they are established by a third party and consider the environmental impacts of a product from cradle to grave. However, the labeling program will only be effective if linked with complementary program of consumer education and up on restriction of umbrella claims by the producers.

2.3.2.7 Cleaner production

Cleaner production is one of the tools, which has lot of bearing on environmental pollution control. It is also seen that the approach is changing with time *i.e.*, dumping-to-control-to-recycle-to-prevention. Promotion of cleaner production principles involves an insight into the production processes not only to get desired yield but also to optimize on raw material consumption *i.e.*, resource conservation and implications of the waste treatment and disposal.

2.3.2.8 4-R concept

The concept endorses utilization of wastes as by-product to the extent possible *i.e.*, Recycle, Recover, Reuse, Recharge. Recycling refers to using wastes/by-products in the process again as a raw material to maximize production. Recovery refers to engineering means such as solvent extraction, distillation, precipitation, *etc.*, to separate useful constituents of wastes, so that these recovered materials can be used. Re-use refers to the utilization of waste from one process as a raw material to other. Recharging is an option in which the natural systems are used for renovation of waste for further use.

2.3.2.9 Eco-efficiency

The World Business Council on Sustainable Development (WBCSD) defines eco-efficiency as “the delivery of competitively priced goods and services that satisfy human needs and bring quality of life, while progressively reducing ecological impacts and resource intensity throughout the life cycle, to a level at least in line with earth’s carrying capacity”. The business implements the eco-efficiency on four levels *i.e.*, optimized processes, recycling of wastes, eco-innovation and new services. Fussler (1995) defined six dimensions of eco efficiency, which are given below to understand/examine the system.

- **Mass:** There is an opportunity to significantly reduce mass burdens (raw materials, fuels, utilities consumed during the life cycle)
- **Reduce Energy Use:** The opportunity is to redesign the product or its use to provide significant energy savings
- **Reduce Environmental Toxins:** This is concern to the environmental quality and human health. The opportunity here is to significantly control the dispersion of toxic elements.
- **Recycle when Practical:** Designing for recyclability is important
- **Working with Mother Nature:** Materials are borrowed and returned to the nature without negatively affecting the balance of the ecosystem.
- **Make it Last Longer:** It relates to useful life and functions of products. Increasing the functionality of products also increases their eco efficiency.

The competitiveness among the companies and long-term survival will continue and the successful implementation of eco-efficiency will contribute to their success. There is a need to shift towards responsible consumerism equal to the efficiency gains made by corporations – doing more with less.

2.3.2.10 Industrial ecosystem or metabolism

Eco-industrial development is a new paradigm for achieving excellence in business and environmental performance. It opens up innovative new avenues for managing business and conducting economic development by creating linkages among local ‘resources’, including businesses, non-profit groups, governments, unions, educational institutions, and communities can creatively foster the dynamic and responsible growth. Antiquated business strategies based on isolated enterprises are no longer responsive enough to market, environmental and community requirements.

Sustainable eco-industrial development looks systematically at development, business and environment, attempting to stretch the boundaries of current practice - on one level. It is as directly practical as making the right connections between the wastes and resources needed for production and at the other level, it is a whole new way of thinking about doing business and interacting with communities. At a most basic level, it is each organization seeking higher performance within it self. However, most eco-industrial activity is moving to a new level by increasing the inter connections between the companies.

Strategic partnership, networked manufacturing and performed supplier arrangements are all the examples of ways used by the businesses to ensure growth, contain costs and to reach out for new opportunities.

For most businesses, the two essentials for success are the responsive markets and access to cost-effective, quality resources for production or delivering services. In absence of these two factors, virtually every other incentive becomes a minor consideration.

Transportation issues are important at two levels, the ability to get goods to market in an expeditious way is essential to success in this day of just in time inventories. The use of least impact transportation with due consideration of speed and cost supports business success and addresses the concerned in community.

Eco-industrial development works because it consciously mixes a range of targeted strategies shaped to the contours of the local community. Most importantly, it works because the communities want nothing less than the best possible in or near their neighborhood. For companies, it provides a path towards significantly higher operating results and positive market presence. For our environment, it provides great hope that the waste will be transformed in to valued product and that the stewardship will be a joint pledge of both businesses and communities.

2.3.2.11 Voluntary agreements

Voluntary environmental agreements among the industries, government, public representatives, NGOs and other concerned towards attaining certain future demands of the environment are reported to be successful. Such agreements may be used as a tool where Government would like to make the standards stringent in future (phase-wise-stringent). These may be used when conditions are temporary and requires replacing timely replacements. Also, these may be used as supplementary/ complimentary in implementation of the regulation. The agreements may include:

- Target objectives (emission limit values/standards)
- Performance objectives (operating procedures)
- R&D activities – Government and industry may have agreement to establish better control technologies.
- Monitoring & reporting of the agreement conditions by other agents (NGOs, public participants, civil authority *etc.*)

In India, the MoEF, has organized such programme, popularly known as the corporate responsibility for environment protection (CREP) considering identified 17 categories of high pollution potential industrial sectors. Publication in this regard is available with Central Pollution Control Board (CPCB).

2.3.3 Tools for communication

2.3.3.1 State of environment

The Government of India has brought out the state of environment report for entire country and similar reports are available for many of the states. These reports are published at regular intervals to record trends and to identify the required interventions at various levels. These reports consider the internationally accepted DPSIR framework for the presentation of the information. DPSIR refers to

- D – Driving forces – causes of concern *i.e.* industries, transportation *etc.*
- P – Pressures – pollutants emanating from driving forces *i.e.* emission
- S – State – quality of environment *i.e.* air, water & soil quality
- I – Impact – Impact on health, ecosystem, materials, biodiversity, economic damage *etc.*
- R – Responses – action for cleaner production, policies (including standards/guidelines), targets *etc.*

Environment reports including the above elements give a comprehensive picture of specific target area in order to take appropriate measures for improvement. Such reports capture the concerns, which could be considered in EIAs.

2.3.3.2 Corporate environmental reporting

Corporate environmental reports (CERs) are only one form of environmental reporting defined as publicly available, stand alone reports, issued voluntarily by the industries on their environmental activities (Borphy and Starkey-1996). CER is just are a means of environmental improvement and greater accountability, not an end in itself.

Three categories of environmental disclosure are:

- Involuntary Disclosure: Without its permission and against its will (env. Campaign, press *etc.*)
- Mandatory Disclosure: As required by law
- Voluntary Disclosure: The disclosure of information on a voluntary basis

2.4 Objectives of EIA

Objectives of EIA include the following:

- To ensure environmental considerations are explicitly addressed and incorporated into the development decision-making process;
- To anticipate and avoid, minimize or offset the adverse significant biophysical, social and other relevant effects of development proposals;
- To protect the productivity and capacity of natural systems and the ecological processes which maintain their functions; and
- To promote development that is sustainable and optimizes resource use as well as management opportunities.

2.5 Types of EIA

Environmental assessments could be classified into four types *i.e.*, strategic environmental assessment, regional EIA, sectoral EIA and project level EIA. These are precisely discussed below:

Strategic environmental assessment

Strategic Environmental Assessment (SEA) refers to systematic analysis of the environmental effects of development policies, plans, programmes and other proposed strategic actions. SEA represents a proactive approach to integrate environmental considerations into the higher levels of decision-making – beyond the project level, when major alternatives are still open.

Regional EIA

EIA in the context of regional planning integrates environmental concerns into development planning for a geographic region, normally at the sub-country level. Such an approach is referred to as the economic-cum-environmental (EcE) development planning. This approach facilitates adequate integration of economic development with management of renewable natural resources within the carrying capacity limitation to achieve sustainable development. It fulfils the need for macro-level environmental integration, which the project-oriented EIA is unable to address effectively. Regional EIA addresses the environmental impacts of regional development plans and thus, the context for project-level EIA of the subsequent projects, within the region. In addition, if environmental effects are considered at regional level, then cumulative environmental effects of all the projects within the region can be accounted.

Sectoral EIA

Instead of project-level-EIA, an EIA should take place in the context of regional and sectoral level planning. Once sectoral level development plans have the integrated sectoral environmental concerns addressed, the scope of project-level EIA will be quite minimal. Sectoral EIA will help in addressing specific environmental problems that may be encountered in planning and implementing sectoral development projects.

Project level EIA

Project level EIA refers to the developmental activity in isolation and the impacts that it exerts on the receiving environment. Thus, it may not effectively integrate the cumulative effects of the development in a region.

From the above discussion, it is clear that EIA shall be integrated at all the levels *i.e.* strategic, regional, sectoral and the project level. Whereas, the strategic EIA is a structural change in the way the things are evaluated for decision-making, the regional EIA refers to substantial information processing and drawing complex inferences. The project-level EIA is relatively simple and reaches to meaningful conclusions. Therefore in India, the project-level EIA studies are take place on a large-scale and are being considered. However, in the re-engineered Notification, provisions have been incorporated for giving a single clearance for the entire industrial estate for *e.g.*, Leather parks, pharma cities *etc.*, which is a step towards the regional approach.

As we progress and the resource planning concepts emerge in our decision-making process, the integration of overall regional issues will become part of the impact assessment studies.

2.6 Basic EIA Principles

By integrating the environmental impacts of the development activities and their mitigation early in the project planning cycle, the benefits of EIA could be realized in all stages of a project, from exploration and planning, through construction, operations, decommissioning, and beyond site closure.

A properly-conducted-EIA also lessens conflicts by promoting community participation, informing decision makers, and also helps in laying the base for environmentally sound projects. An EIA should meet at least three core values (EIA Training Resource Manual, UNEP 2002):

- Integrity: The EIA process should be fair, objective, unbiased and balanced
- Utility: The EIA process should provide balanced, credible information for decision-making
- Sustainability: The EIA process should result in environmental safeguards

Ideally an EIA process should be:

- Purposive - should inform decision makers and result in appropriate levels of environmental protection and community well-being.
- Rigorous - should apply 'best practicable' science, employing methodologies and techniques appropriate to address the problems being investigated.
- Practical - should result in providing information and acceptable and implementable solutions for problems faced by proponents.
- Relevant - should provide sufficient, reliable and usable information for development planning and decision making.
- Cost-effective - should impose minimum cost burdens in terms of time and finance on proponents and participants consistent with meeting accepted requirements and objectives of EIA.
- Efficient - should achieve the objectives of EIA within the limits of available information, time, resources and methodology.
- Focused - should concentrate on significant environmental effects and key issues; *i.e.*, the matters that need to be taken into account in making decisions.
- Adaptive - should be adjusted to the realities, issues and circumstances of the proposals under review without compromising the integrity of the process, and be iterative, incorporating lessons learned throughout the project life cycle.
- Participative - should provide appropriate opportunities to inform and involve the interested and affected publics, and their inputs and concerns should be addressed explicitly in the documentation and decision making.
- Inter-disciplinary - should ensure that appropriate techniques and experts in relevant bio-physical and socio-economic disciplines are employed, including use of traditional knowledge as relevant.

- Credible - should be carried out with professionalism, rigor, fairness, objectivity, impartiality and balance, and be subject to independent checks and verification.
- Integrated - should address the interrelationships of social, economic and biophysical aspects.
- Transparent - should have clear, easily understood requirements for EIA content; ensure public access to information; identify the factors that are to be taken into account in decision making; and acknowledge limitations and difficulties.
- Systematic - should result in full consideration of all relevant information on the affected environment, of proposed alternatives and their impacts, and of the measures necessary to monitor and investigate residual effects.

2.7 Project Cycle

The generic project cycle including that of Cement Plants has six main stages:

1. Project concept
2. Pre-feasibility
3. Feasibility
4. Design and engineering
5. Implementation
6. Monitoring and evaluation

It is important to consider the environmental factors on an equal basis with technical and economic factors throughout the project planning, assessment and implementation phases. Environmental considerations should be introduced at the earliest in the project cycle and must be an integral part of the project pre-feasibility and feasibility stage. If the environmental considerations are given due respect in the site selection process by the project proponent, the subsequent stages of the environmental clearance process would get simplified and would also facilitate easy compliance to the mitigation measures throughout the project life cycle.

A project's feasibility study should include a detailed assessment of significant impacts and the EIA include a detailed prediction and quantification of impacts and delineation of Environmental Management Plan (EMP). Findings of the EIA study should preferably be incorporated in the project design stage so that the project is studied, the site alternatives are required and necessary changes, if required, are incorporated in the project sight at the design stage. This practice will also help the management in assessing the negative impacts and in designing cost-effective remedial measures. In general, EIA enhances the project quality and improves the project planning process.

2.8 Environmental Impacts

Environmental impacts resulting from proposed actions can be grouped into following categories:

- Beneficial or detrimental
- Naturally reversible or irreversible
- Repairable via management practices or irreparable
- Short term or long term

- Temporary or continuous
- Occurring during construction phase or operational phase
- Local, regional, national or global
- Accidental or planned (recognized before hand)
- Direct (primary) or Indirect (secondary)
- Cumulative or single

The category of impact as stated above, and the significance will facilitate the Expert Appraisal Committee (EAC)/State Level EAC (SEAC) to take a look at the ToR for EIA studies, as well as, in decision making process about the developmental activity.

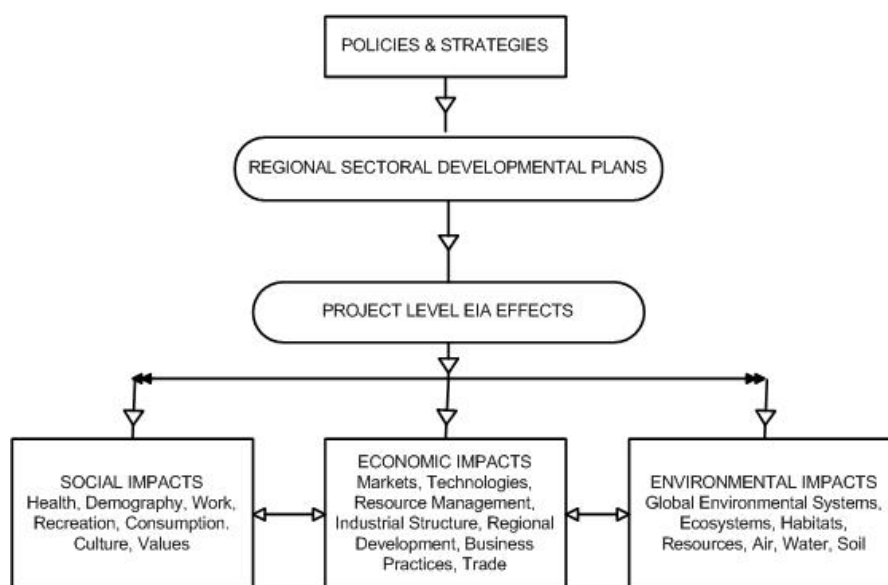

Figure 2-2: Types of Impacts

The nature of impacts could fall within three broad classifications *i.e.*, direct, indirect and cumulative, based on the characteristics of impacts. The assessment of direct, indirect and cumulative impacts should not be considered in isolation or considered as separate stages in the EIA. Ideally, the assessment of such impacts should form an integral part of all stages of the EIA. The TGM does not recommend a single method to assess the types of impacts, but suggests a practical framework/ approach that can be adapted and combined to suit a particular project and the nature of impacts.

2.8.1 Direct impacts

Direct impacts occur through direct interaction of an activity with an environmental, social, or economic component. For *example*, a discharge of cement plant or an effluent from the Effluent Treatment Plant (ETP) into a river may lead to a decline in water quality in terms of high biochemical oxygen demand (BOD) or dissolved oxygen (DO) or rise of water toxins.

2.8.2 Indirect impacts

Indirect impacts on the environment are those which are not a direct result of the project, often produced away from or as a result of a complex impact pathway. The indirect impacts are also known as secondary or even tertiary level impacts. For example, ambient air SO₂ rise due to stack emissions may deposit on land as SO₄ and cause acidic

soils. Another example of indirect impact is the decline in water quality due to rise in temperature of water bodies receiving cooling water discharge from the nearby industry. This in turn, may lead to a secondary indirect impact on aquatic flora in that water body and may further cause reduction in fish population. Reduction in fishing harvests, affecting the incomes of fishermen is a third level impact. Such impacts are characterized as socio-economic (third level) impacts. The indirect impacts may also include growth-inducing impacts and other effects related to induced changes to the pattern of land use or additional road network, population density or growth rate. In the process, air, water and other natural systems including the ecosystem may also be affected.

2.8.3 Cumulative impacts

Cumulative impact consists of an impact that is created as a result of the combination of the project evaluated in the EIA together with other projects in the same vicinity, causing related impacts. These impacts occur when the incremental impact of the project is combined with the cumulative effects of other past, present and reasonably foreseeable future projects. Figure 2-3 depicts the same. Respective EAC may exercise their discretion on a case-by-case basis for considering the cumulative impacts.

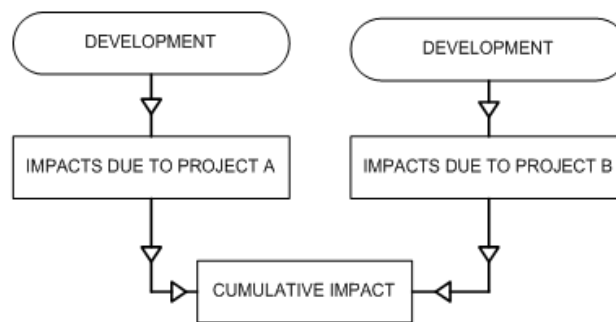

Figure 2-3: Cumulative Impact

2.8.4 Induced impact

The cumulative impacts can be due to induced actions of projects and activities that may occur if the action under assessment is implemented such as growth-inducing impacts and other effects related to induced changes to the pattern of future land use or additional road network, population density or growth rate (*e.g.*, excess growth may be induced in the zone of influence around a cement project, and in the process causing additional effects on air, water and other natural ecosystems). Induced actions may not be officially announced or be part of any official plan. Increase in workforce and nearby communities contributes to this effect.

They usually have no direct relationship with the action under assessment, and represent the growth-inducing potential of an action. New roads leading from those constructed for a project, increased recreational activities (*e.g.*, hunting, fishing), and construction of new service facilities are examples of induced actions.

However, the cumulative impacts due to induced development or third level or even secondary indirect impacts are difficult to be quantified. Because of higher levels of uncertainties, these impacts cannot normally be assessed over a long time horizon. An EIA practitioner usually can only guess as to what such induced impacts may be and the

possible extent of their implications on the environmental factors. Respective EAC may exercise their discretion on a case-by-case basis for considering the induced impacts.

2.9 Significance of Impacts

This TGM establishes the significance of impacts first and proceeds to delineate the associated mitigation measures. So the significance here reflects the “worst-case scenario” before mitigation is applied, and therefore provides an understanding of what may happen if mitigation fails or is not as effective as predicted. For establishing significance of different impacts, understanding the responses and interaction of the environmental system is essential. Hence, the impact interactions and pathways are to be understood and established first. Such an understanding will help in the assessment process to quantify the impact as accurately as possible. Complex interactions, particularly in the case of certain indirect or cumulative impacts, may give rise to non-linear responses which are often difficult to understand and therefore their significance is difficult to assess. It is hence understood that indirect or cumulative impacts are more complex than the direct impacts. Currently the impact assessments are limited to direct impacts. In case mitigation measures are delineated before determining significance of the effect, the significance represents the residual effects.

However, the ultimate objective of an EIA is to achieve sustainable development. The development process shall invariably cause some residual impacts even after implementing an EMP effectively. Environmentalists today are faced with a vital, not-easy-to-answer question—“What is the tolerable level of environmental impact within the sustainable development framework?”. As such, it has been recognized that every ecosystem has a threshold for absorbing deterioration and a certain capacity for self-regeneration. These thresholds based on concept of carrying capacity are as follows:

- Waste emissions from a project should be within the assimilative capacity of the local environment to absorb without unacceptable degradation of its future waste absorptive capacity or other important services.
- Harvest rates of renewable resource inputs should be within the regenerative capacity of the natural system that generates them; depletion rates of non-renewable inputs should be equal to the rate at which renewable substitutes are developed by human invention and investment.

The aim of this model is to curb over-consumption and unacceptable environmental degradation. But because of limitation in available scientific basis, this definition provides only general guidelines for determining the sustainable use of inputs and outputs. To establish, the level of significance for each identified impact, a three-stage analysis may be referred:

- First, an impact is qualified as being either negative or positive.
- Second, the nature of impacts such as direct, indirect, or cumulative is determined using the impact network
- Third, a scale is used to determine the severity of the effect; for example, an impact is of low, medium, or high significance.

It is not sufficient to simply state the significance of the effect. This determination must be justified, coherent and documented, notably by a determination methodology, which must be described in the methodology section of the report. There are many recognized methodologies to determine the significance of effects.

2.9.1 Criteria/methodology to determine the significance of the identified impacts

The criteria can be determined by answering some questions regarding the factors affecting the significance. This will help the EIA stake-holders, the practitioner in particular, to determine the significance of the identified impacts eventually. Typical examples of such factors include the following:

- Exceeding threshold Limit: Significance may increase if a threshold is exceeded. *e.g.*, Emissions of particulate matter exceed the permissible threshold.
- Effectiveness of mitigation: Significance may increase as the effectiveness of mitigation measures decreases. *e.g.*, control technologies, which may not assure consistent compliance to the requirements.
- Size of study area: Significance may increase as the zone of effects increases.
- Incremental contribution of effects from action under review: Significance may increase as the relative contribution of an action increases.
- Relative contribution of effects of other actions: Significance may decrease as the significance of nearby larger actions increase.
- Relative rarity of species: Significance may increase as species becomes increasingly rare or threatened.
- Significance of local effects: Significance may increase as the significance of local effects is high.
- Magnitude of change relative to natural background variability: Significance may decrease if effects are within natural assimilative capacity or variability.
- Creation of induced actions: Significance may increase as induced activities also highly significant
- Degree of existing disturbance: Significance may increase if the surrounding environment is pristine:

For determining significance of impacts, it is important to remember that secondary and higher order effects can also occur as a result of a primary interaction between a project activity and the local environment. Wherever a primary effect is identified, the practitioner should always think if secondary or tertiary effects on other aspects of the environment could also arise.

The EIA should also consider the effects that could arise from the project due to induced developments, which take place as a consequence of the project. *Ex.* Population density and associated infrastructure and jobs for people attracted to the area by the project. It also requires consideration of cumulative effects that could arise from a combination of the effects due to other projects with those of other existing or planned developments in the surrounding area. So the necessity to formulate a qualitative checklist is suggested to test significance, in general.

3.

ABOUT CEMENT PLANTS INCLUDING PROCESS AND POLLUTION CONTROL TECHNOLOGIES

3.1 Introduction

Cement is the basic material for buildings and civil engineering constructions. Portland cement, the most widely used cement in concrete construction, was patented in 1824. Output from the cement industry is directly related to the state of the construction business in general and therefore tracks the overall economic situation closely. Cement is a mixture of compounds, consisting mainly of silicates and aluminates of calcium, formed out of raw materials consisting calcium oxide, silica, aluminum oxide and iron oxide.

Indian cement industry is the second largest in the world. The Indian cement industry witnessed an unprecedented growth as a sequel to the liberalization policies the Government initiated with partial decontrol in 1982 culminating in total decontrol in 1989. Latest available technologies were introduced during the eighties calling for highly trained and skilled personnel. As per the reports, the cement industry is growing at the rate of 8 to 10 % CAGR. The per capita consumption of cement in India (about 150 kg) is much less compared to average per capita consumption (about 380 kg) for the rest of the world. Hence Indian cement industry has large potential to grow. As Figure 3.1 shows, cement production in India has grown steadily during the last two decades.

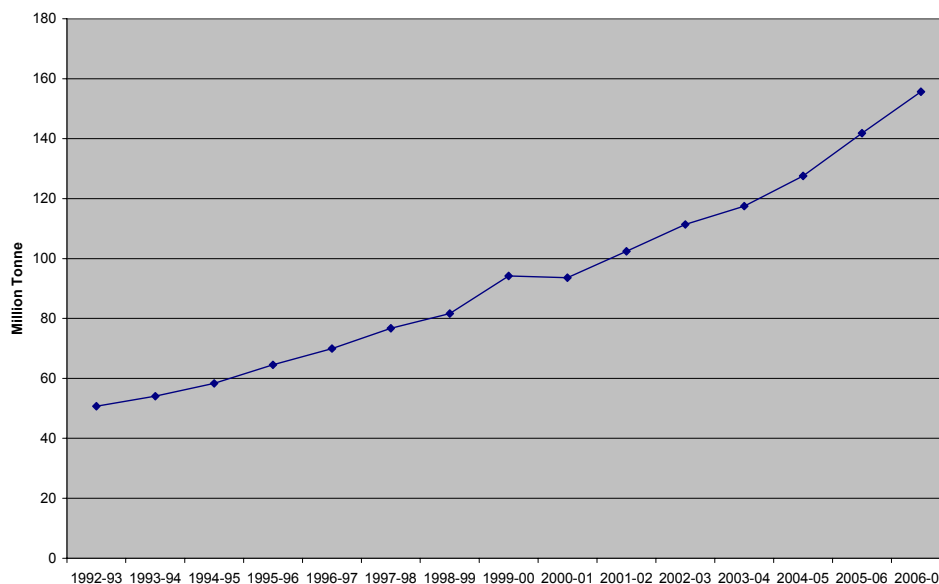

Figure 3-1: Growth of Cement Production in India

Source: CMA

The industry presents a mixed picture with many new plants that employ state-of-the-art dry process technology and a few old wet process plants having wet process kilns. At present, about 96% of India’s cement production is from dry process kilns, a further 3%

of production is accounted for by wet process kilns, with the remainder of Indian production -about 1%- now coming from semi-dry and semi-wet process kilns.

The cement manufacturing units– with a slight regional imbalance –is spread all over India. All the plants are situated in proximity to limestone deposits, exploiting the natural resources to the full extent. Andhra Pradesh, Madhya Pradesh, Gujarat, Tamil Nadu, Rajasthan, Karnataka and Chattisgarh are the major cement producing states. Basically, there are seven clusters in our country namely Satna, Bilaspur, Chanderia, Gulbarga, Chandrapur, Yerraguntla and Nalgonda, which contribute more than 50% of total cement production. Table 3.1 shows Highlights of the Indian Cement Industry.

Table 3-1: Indian Cement Industry (April 2008)

Large Plants (> 200 TPD)	
Companies (Members) (Nos)	51
Cement Plants (Nos)	140
Installed Capacity in Million Tonne (MT)	198.30
Cement Production (MT)	155. 66
Plants with Capacity of MT and above (Nos)	88
Manpower Employed Approx.	1,35,000
Turnover in 2007 (Million US\$) around	17,500
Mini & White Cement Plants (≤ 200 TPD)	
Cement Plants Approx.	365
Installed Capacity (MT)	11.10 (P)
Cement Production (MT) 2007-08	6.00 (P)
Source: CMA	

Cement is manufactured by burning a mixture of calcareous and argillaceous raw materials and suitable corrective materials at high temperatures in a kiln, and then finely grinding the resulting clinker along with gypsum. The end product thus obtained is called Ordinary Portland Cement (OPC).

In India, OPC is classified in three strength grades, viz. 33 grade, 43 grade and 53 grade, the numbers indicating the compressive strength (in MPa) obtained after 28 days, when tested as per the stipulated procedure. Apart from OPC of the three strength grades mentioned above, there are several other types of OPC, most of them meant for special purposes, e.g., rapid hardening Portland cement, sulphate resistant cement, white cement, oil well cement, etc. In addition, there are blended and composite cements like Portland Pozzolana Cement (PPC), Portland Blast Furnace Slag Cement (PBFS), masonry cement, supersulphated cement, etc. Production of all these varieties of cement is required to conform to the respective specifications of Bureau of Indian Standards (BIS). PPC enjoys the major share of the total cement production in India followed by OPC and PSC types.

The figure below shows a positive trend of increased use of blended cement. The total share of blended cements (PPC and PSC) is 67 % (2007 data).

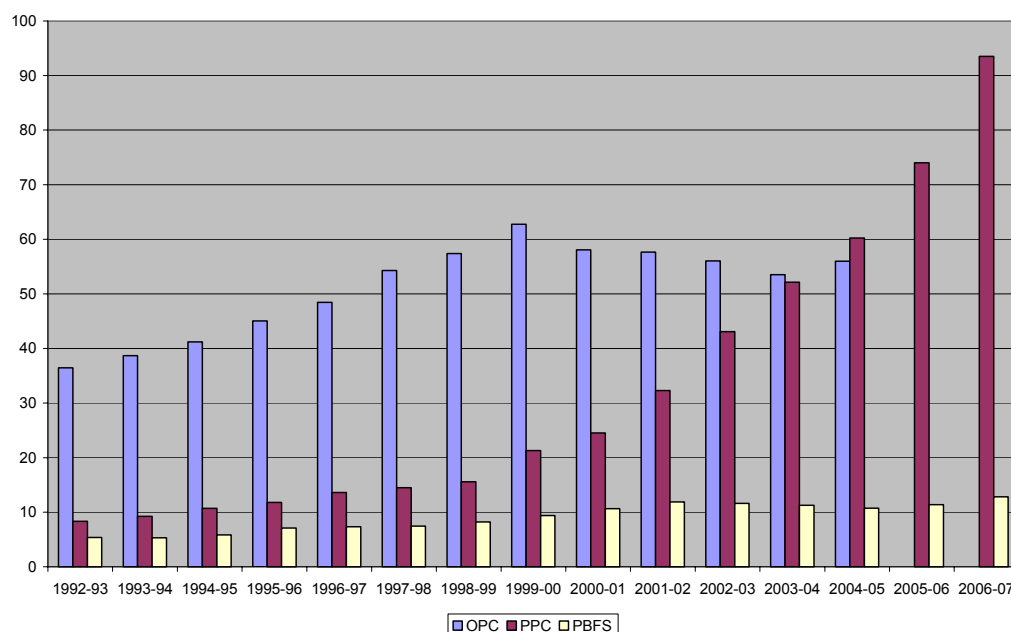

Figure 3-2: Yearly Production of Three Major Types of Cement

Table 3-2: Total Cement Production from 2006-08

S.No	Cement Production	2006-07	2007-08
1.	Total Production of Cement (Million Tonnes Per Annum), Large Plants	155. 66	168.32
2.	Production of PPC (MTPA)	93.52	111.21
3.	Production of PBFS (MTPA)	12. 84	13.88
4.	Consumption of Fly Ash (MTPA)	22. 63*	27.80
5.	Consumption of Blast Furnace Slag (MTPA)	7.06*	7.63

Source: CMA

The cement industry is an energy intensive industry with total energy cost typically accounting for 40 – 45 % of production costs (i.e., excluding capital costs). The most commonly used fuel in the cement industry is pulverized coal from indigenous sources and imported (black coal and lignite). In addition, petroleum coke (pet-coke) can also be used. The annual consumption by the cement Industry is about 30 million tonnes. It is estimated that nearly 6 to 7 million tonne of imported coal will be used by the year 2010. Cement industry also consumes about 1.3 to 1.4 Mta of Pet-coke.

Coal and pet-coke generate higher emissions of greenhouse gases (GHG) than fuel oil and natural gas. In addition, high sulphur content in the fuel (characteristic of pet-coke) may create problems, including mainly sulphur buildup on rings in the kiln. Gaseous emission of SO₃ is discussed later. Use of waste fuel as an alternative to traditional fuel is becoming increasingly common in the cement industry the world over.

3.2 Scientific Aspects

3.2.1 Industrial process

The cement manufacturing process involves mining, crushing, grinding of raw materials (principally limestone and clay), blending of raw meal, calcining the materials in a rotary kiln, cooling the resulting clinker, mixing the clinker with gypsum, and milling, storing, and bagging the finished cement.

The raw materials used to make cement may be divided into four basic components: lime (calcareous), silica (siliceous), alumina (argillaceous), and iron (ferriferous). Approximately 1450 kilograms (kg) of dry raw materials are required to produce one tonne of cement. Approximately 35% of the raw material weight is removed as carbon dioxide (CO₂) and watervapour.

The basic chemistry of cement manufacturing process begins with the decomposition of clay minerals into SiO₂ and Al₂O₃ on the one hand, and of calcium carbonate (CaCO₃) at about 900 °C to leave calcium oxide (CaO, lime) liberating CO₂, on the other hand. The latter process is known as calcination. This is followed by the clinkering process, in which the CaO reacts at high temperature (typically 1450 °C) with silica, alumina, and ferrous oxide to form the silicates, aluminates, and ferrites of calcium. The resultant clinker is then ground together with gypsum and other additives to produce cement.

There are four main process routes for the manufacture of cement

- DRY PROCESS — The raw materials are ground and dried to raw meal in the form of a flowable powder. The dry raw meal is fed in to the pre-heater or precalciner kiln or, more rarely, to a long dry kiln.
- SEMI-DRY PROCESS — Dry raw meal is palletized with water and fed into a grate preheater before the kiln or to a long kiln equipped with crosses.
- SEMI-WET PROCESS — the slurry (see wet process below) is first dewatered in filter presses. The filter cake is extruded into pellets and fed either to a grate pre-heater or directly to a filter cake drier for raw meal production.
- WET PROCESS — The raw materials (often with high moisture content) are ground in water to form a pumpable slurry. The slurry is either fed directly into the kiln or first to slurry drier.

In the dry process, the moisture content of the feed material can be up to 8 % in case of ball mill or roller press and up to 15 % in case of grinding operation with vertical roller mills (VRM). The dried materials are then pulverized into a powder and fed directly into a rotary kiln. Usually, the kiln is a long, nearly horizontal (slope < 3 – 4 %), steel cylinder with a refractory brick lining. The kilns rotate about the longitudinal axis. The pulverized raw materials are fed into the upper end and travel slowly to the lower end. The kilns are fired from the lower end so that hot gases pass upward through the raw material. Drying, decarbonation, and calcining are accomplished as the material travels through the heated kiln, finally burning to incipient fusion and forming the clinker. The clinker is cooled, mixed with about 5% gypsum by weight and ground to the final product fineness and particle size distribution (PSD).

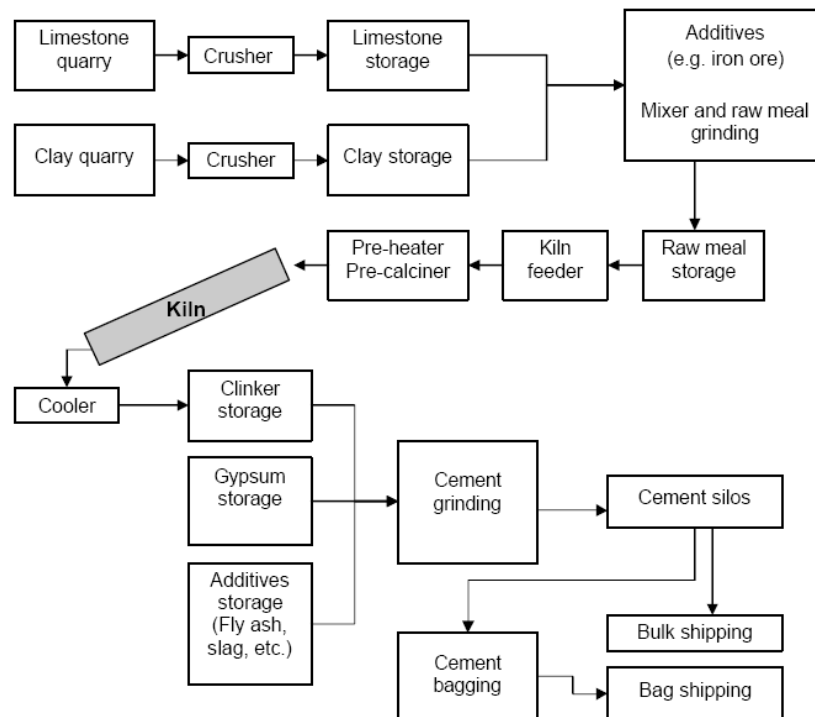

Figure 3-3: Cement Manufacturing Process (dry SP/PC Kiln)

In the wet process, slurry is made by adding water to the initial grinding operation. Proportioning may take place before or after the grinding step. After the materials are mixed, the excess water is removed and final adjustments are made to obtain the desired composition. The final homogeneous mixture is fed to the kilns as slurry of 30 to 40 % moisture or as a wet filtrate of about 20 % moisture. The burning, cooling, addition of gypsum, and storage are carried out as in the dry process.

The choice of process to a large extent is determined by the moisture content of the raw materials. Wet processes are more energy consuming, and thus more expensive. Plants using semi-dry processes are likely to convert to dry process technologies whenever expansion or major improvement is required. Normally, plants using wet or semi-wet processes only have access to moist raw materials. The following sub-processes are in all processes:

- Winning of raw materials
- Raw materials storage and preparation
- Fuels storage and preparation
- Clinker burning
- Cement grinding and storage
- Packing and dispatch

State-of-Art Cement Plant

The core equipment in different sections of a State-of-Art dry process cement plant is as under;

Pyroprocessing

- Cement kiln with $l/d \approx 12$, two supports,
- Five or six-stage preheater with low pressure drop,
- Low NO_x precalcinator with pre-combustion chamber, amenable to burning secondary fuels,
- Low primary air, high momentum, multi-channel burner,
- Grate cooler with high heat recuperation efficiency (≈ 78 percent) and low air requirement ($\approx 1.6 \text{ Nm}^3/\text{kg}$ clinker).
- Improved drives (5000 – 10000 kW).

Size reduction

- Double rotor impact crushers or twin roll crushers for limestone,
- Vertical roller mills / Horomill for raw grinding,
- VRM for coal / Pet-coke grinding,
- Roller press for slag grinding,
- Roller press and ball mill for finish grinding,
- High efficiency separators, static-dynamic separator for cement grinding.

3.2.2 Raw material inputs and pollution outputs in the production line

The typical raw material inputs and pollution outputs of a cement manufacturing process is shown in Figure 3.4.

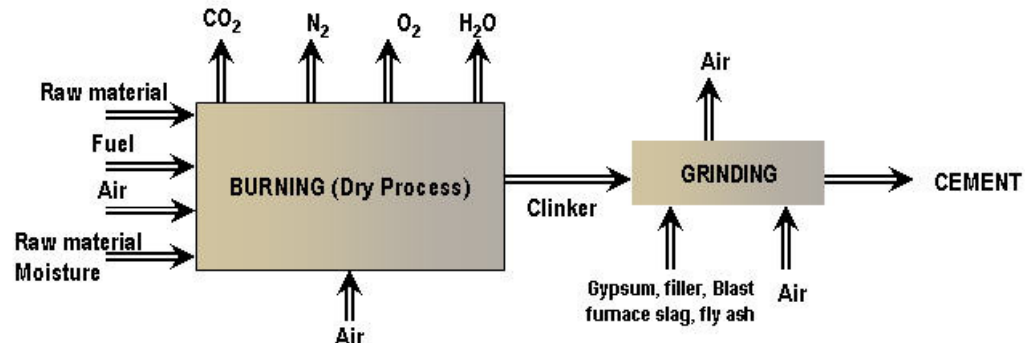

Figure 3-4: Cement Manufacturing Process – Inputs and Outputs

Naturally occurring calcareous deposits such as limestone, marl or chalk provide the source for calcium carbonate. Silica, iron oxide and alumina are found in various ores and minerals, such as sand, shale, clay, bauxite and iron ore. In Indian cement plants, siliceous impurities in limestone and ash contained in coal provide silica, alumina and ferrous phases, and clay minerals are seldom added as raw material. Fly ash from Thermal Power stations, blast furnace slag, and calcium carbonate-bearing sludge can also be used as partial replacements for the natural raw materials, depending on their physical and chemical characteristics.

The main environmental issues associated with cement projects primarily include the following:

- Air Emissions including dust
- Exploitation of natural resources for raw materials
- Energy consumption and fuels

- Wastewater
- Solid waste generation
- Noise
- Vibration

A. Consumption of raw materials

Cement manufacturing is a high volume process. The figures in Table 3-3 indicate typical average consumptions of raw materials for the production of cement in India.

Table 3-3: Raw Material Consumption of Cement

Materials	Relative mass, %
Cement Clinker / OPC	
Limestone	150
Clay component / Sandstone	< 5
Bauxite	2 – 4
Iron ore / Roasted Pyrite	1 – 3
Mineralisers	< 1
Coal, including Pet-coke	20
Gypsum or other Sulphates	5
Blended Cements	
Fly Ash	15 – 25 #
Granulated Slag	35 – 50 #
Source: CPCB	

NOTE:

-Indian Standard IS: 1489 permits addition of up to 35 % of fly ash in the manufacture of PPC, however, 15 to 25 % is common. IS: 455 permits addition of granulated slag up to 70 % in the manufacture of PSC. However, the industry norm is up to 50 %.

B. Energy consumption

The dominant use of thermal energy in cement manufacture is as fuel for the kiln. The main uses of electricity are in the mills (finish grinding and raw grinding), drives, and the fans (kiln/raw mill and cement mill) which together account for more than 80% of electrical energy usage. On average, energy costs - in the form of fuel and electricity- represent about 40 – 45% of the total production cost involved in producing a tonne of cement. Both, thermal and electrical energy comprise about half each of this overall energy cost.

The theoretical thermal energy required for the chemical reactions involved in clinker formation is about 400 kCal/kg of clinker. Table 3-4 shows the energy consumption in Indian cement sector. Whereas tables 3-5 and 3-6 show the specific thermal energy consumption in various kiln systems and specific electric energy consumption respectively.

Table 3-4: Thermal and Electrical Consumption in Dry Process Cement Plants in India

	Best	Average
Thermal energy, (kCal/kg of clinker)	663	723
Electrical Energy (kWh/ tonne cement)	63	82
Source: CMA, (2006 – 2007)		

Table 3-5: Specific Thermal Energy Consumption in Indian Cement Sector

Kiln Process	Thermal heat Consumption (kCal / kg Clinker)
Wet Process with Internals	1300-1400
Long dry process with Internals	1100-1200
4-stage Cyclone Preheater	775 - 800
4-Stage Cyclone Preheater Plus Calciner	750-775
5-Stage Cyclone Preheater Plus Calciner plus high Efficiency cooler	690-725
6-Stage Cyclone Preheater Plus Calciner plus high Efficiency cooler	670 - 690
Source: NCB Operational Norms, 2005	

Table 3-6: Specific Electric Energy Consumption (kWh/t of Material)

S. No.	Section	Range
1	Mining	0.5 – 1.0
2	Crushing – Limestone	0.8 – 1.2
	Coal / Pet-coke	0.8 – 1.5
3	Raw Material Grinding - Ball mill	17 – 26
	VRM	12 – 20
	Roller Press	14 – 18
4	Coal / Pet-coke Grinding – Ball Mill	25 – 30
	VRM (Coal)	20 – 23
	VRM (Pet-coke)	30 – 35
5	Pyroprocessing - PC Kilns	20 – 28
	SP Kilns	25 – 30
6	Cement Grinding – Ball Mill	28 – 38
	VRM	20 – 23
	Roller Press (Semi Finish mode)	24 – 30
7	Slag Grinding – Roller Press	28 – 30 (Finish Mode)

S. No.	Section	Range
8	Packing and Dispatch	1.0 – 2.0
Source: NCB Operational Norms, 2005		

C. Air emissions

Dust and gaseous emissions are the main pollutants during operation of the cement plant. Air emissions in cement manufacturing process are generated by the handling and storage of raw, intermediate and final materials, and by the operation of kiln systems, clinker coolers, and mills. Air emissions are mainly gaseous or in the form of particles loaded by adsorbed gases; the latter can be regarded as a constituent of dust.

The main releases from the production of cement are releases to air from the kiln system. These are derived from the physical and chemical reactions involving the raw materials and the combustion of fuels. The main gaseous pollutants relevant to cement manufacturing are:

- Oxides of nitrogen (NO_x) and other nitrogen compounds;
- Sulphur dioxide (SO₂) and other sulphur compounds;
- Carbon oxides (CO and CO₂)

Cement plant operation and abatement techniques for air pollution generally focus on these three pollutants. Other pollutants also to be considered in relation to the production of cement, especially with secondary fuels are:

- volatile organic compounds (VOC)
- polychlorinated dibenzodioxins and dibenzofurans (PCDDs and PCDFs)
- metals and their compounds
- Hydrogen Fluoride
- Hydrochloric Acid (HCl)

Other emissions, the effect of which is normally slight and/or local, are waste, noise and odour.

In all kilns the solid material moves counter currently to the hot combustion gases. This counter current flow affects the release of pollutants, since it acts as a built-in circulating fluidized bed. Many components that result from the combustion of the fuel or from the transformation of the raw material into clinker remain in the gas phase only until they are absorbed by, or condensed on, the raw material flowing counter currently.

The adsorptive capacity of the material varies with its physical and chemical state. This in turn depends on its position within the kiln system. For instance, material leaving the calcinations stage of a kiln has high calcium oxide content and therefore has a high absorptive capacity for acid species, such as HCl, HF and SO₂.

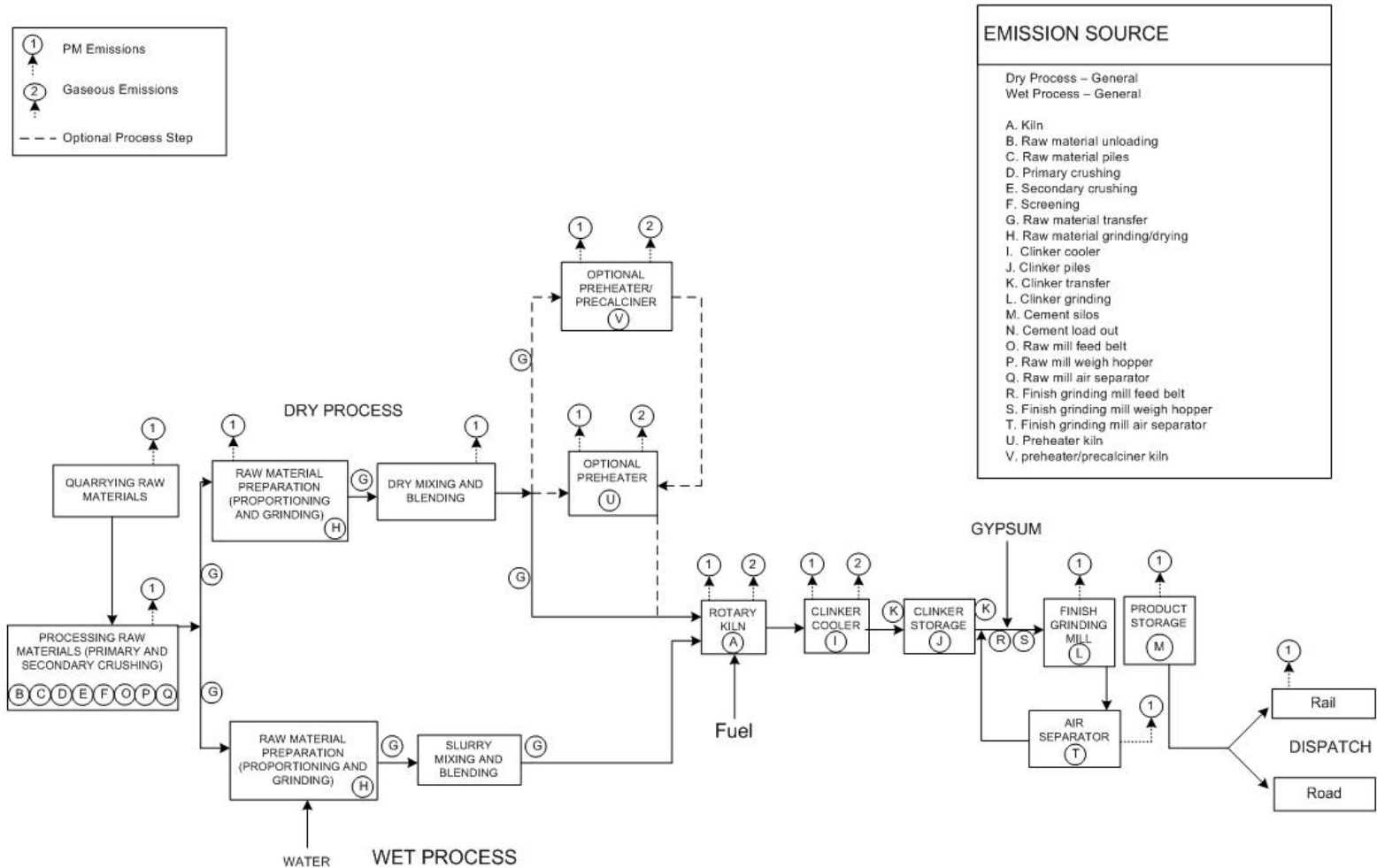

Figure 3-5: Point Sources from a Cement Manufacturing Process

D. Particulate matter (dust)

Traditionally, the emission of dust particularly from kiln stacks has been the main environmental concern in relation to cement manufacture. Dust is generated at all stages in cement manufacturing process. The dust generation in cement plant is basically from the stacks of various sections like crusher, raw mill, coal mill, kiln, clinker cooler, cement mill and packing plant. These are known as process dust or point sources, while dusts arising from material handling, storage and transportation *etc.*, is known as fugitive dust emission. The design and reliability of modern electrostatic precipitators and bag filters ensure dust releases can be reduced to levels where they cease to be significant.

Fugitive dust emissions can arise during the storage and handling of materials and solid fuels, and also from road surfaces. Particulate releases from packing and dispatch of clinker/cement can also be significant. The impact of fugitive emissions can cause increase in levels of dust locally, whereas the process dust emissions (generally from high stacks) can have impact on the air quality over a much larger area. The sources of fugitive dust generation are given in Table 3-7. Tables 3-8 and 3-9 shows PM emission factors for various sections of plants employing dry process and wet processes respectively.

Table 3-7: Sources of Fugitive Dust Emission

Section	Source
Limestone quarry	Drilling, blasting, loading transportation to crushers and to stacker/reclaimer
Crusher	Unloading, crushing, screening, conveying <i>etc.</i>
Pre-blending and storage	Open stockpile
Raw mill	Drying of materials, feeding to grinding system
Blending and homogenization	Filling and discharge of silos
Kiln	Kiln feed
Coal mill	Conveying and feeding of coal
Clinker cooler	Conveying of clinker
Cement mill	Conveying and feeding of clinker, gypsum <i>etc.</i>
Packing plant	Bagging, conveying and loading
Handling of waste dust	Disposal of dust
Unpaved roads	Vehicular movement

Table 3-8: PM Emission Factors with and without APCD for Cement Manufacturing Industries in India (Dry Type)

S. No.	Section	Sub Section	Emission Factor in kg/ tonne of Clinker Produced	
			Without APCD	With APCD
1.	Kiln	Kiln, Raw mill & Clinker Cooler	94	0.98
2.	Grinding	Cement mill & Coal mill	257	0.21

S. No.	Section	Sub Section	Emission Factor in kg/ tonne of Clinker Produced	
			Without APCD	With APCD
3.	Others	Packing, Raw mill silo, Cement mill silo	7	0.01
Total			358	1.20

Table 3-9: PM Emission factors with and without APCD for Cement Manufacturing Industries in India (Wet Process)

S. No.	Section	Sub Section	Emission Factor in kg/ tonne of Clinker Produced	
			Without APCD	With APCD
1.	Kiln	Kiln, Raw mill & Clinker Cooler	174	0.20
2.	Grinding	Cement mill & Coal mill	123	0.02
3.	Others	Packing, Raw mill silo, Cement mill silo	6	0.03
Total			303	0.25
Source: CPCB COINDS				

Oxides of nitrogen

The combustion air in the kiln system contains nearly 79 % of Nitrogen. NO_x is formed during combustion,. Nitrogen oxide as NO comprises 90 % or more of oxides of Nitrogen emitted from cement kiln stack, and balance of NO_x consists of NO₂. At the burning zone, having high gas temperature ($\approx 1850^{\circ}\text{C}$), NO_x forms by direct oxidation of atmospheric Nitrogen. At relatively lower temperature ($\approx 1200^{\circ}\text{C}$) in the Calciners, formation of thermal NO_x ceases. Any Nitrogen contained in the fuel used can be oxidized to NO_x at any of the combustion temperature that exits in the kiln system.

Prompt NO_x is formed by fuel-derived radicals such as CH and CH₂, reacting with atmospheric N₂ in hydrocarbon flames. NO is then formed by subsequent oxidation. Once HCN and CN are formed, they can also lead to formation of NO. Prompt NO_x, formed through such mechanisms, is a minor component of total NO_x emissions from a precalcinator kiln system. Table 3-10 shows NO_x emission factors and emission concentrations for different types of processes/ kilns.

Table 3-10: NO_x Emission Factors and Concentrations

Process/Kiln Type	Type of Control	NO _x Emission Factor (kg/ tonne of clinker)	NO _x concentration (mg/Nm ³)
PH/PC kilns	None	0.4-4.0	200-2000
	SNCR	0.4-0.8	200-400
PH kilns	None	1.3-5. 5	650-2550
Long dry kilns	None	3.1-5. 8	1550-2650
Wet kilns	None	1.8-6.2	900-3000

Sulphur dioxide

Sulphur may occur in small amounts in raw materials for cement manufacturing, and also in fuels, particularly pet-coke. The release of oxides of sulphur is attributed to combustion and counter-current flow of solid materials and hot combustion gases. SO₂ generation is mainly from the readily volatile sulphur compounds, in the form of either Sulphide or organic compounds. This takes place at about 300 – 600 °C in the upper cyclone stages of the preheater system. Sulphur, which is not readily volatile, is liberated at about 900 °C at the kiln inlet region and is reabsorbed in the lower region of the preheater.

Cement manufacturing process has in-built de-sulphurisation mechanism. From the raw materials, lime and alkali react with sulphur compounds and trap it in the clinker. Nearly 70 to 90 % of sulphur gets trapped in this way, and only 10 to 30% would appear in the stack gases. The emission factor and concentrations in the flue gas reported by different agencies are represented in the Table 3-11 below.

Table 3-11: SO₂ Emission Factors and Concentrations

Process/ kiln type	Type of control	Oxides of sulphur emission factor (kg/ tonne of clinker)	Oxides of Sulphur Concentration (mg/Nm ³)
PH kilns and PH/ PC kilns	None	BDL-0.50	BDL-150
Long dry kilns	None	4.9	2450
	Dry Scrubbers	< 0.80	< 400
	Activated coke	< 0.1	< 50
Wet kilns	None	2. 6-4.9	1300-2450

Carbon oxides

Formation of CO₂ is due to;

- Decarbonation of Calcium carbonate into CaO and CO₂. Calcination of one tonne of limestone gives rise to 0.44 T of CO₂.
- Burning of fossil fuels in the kiln, and
- Electricity used in various services, *e.g.* fans, motors, captive power generation *etc.*

As a rough estimate, total CO₂ emission per T of cement range from 0.85 to 1.15 T, the approximate contribution being;

- Calcination – 50 – 55 %,
- Fuel combustion – 40 – 50 %,
- Electricity – 0 – 10 %.

CO – Carbon mono-oxide forms due to insufficient supply of oxygen in the air – fuel mix. Since complete combustion of fuel is always attempted with excess air, normally, no trace of CO should be found in the exit gas; in any case, it is not allowed to exceed 1000 ppm.

Volatile organic compounds (VOC)

VOCs are aliphatic or aromatic hydrocarbons with low molecular weight. Poly aromatic hydrocarbons (PAH) containing three or more benzene rings are atmospheric pollutants that result from incomplete combustion of organic matter in fuels. These polluting substances are likely to be present only if high calorific value waste fuels (described later) containing such compounds is used. The probability of VOCs appearing in exhaust gases is low, as they are oxidized in low temperatures, much below those prevailing even in Calciners. The organic matter is released between temperatures of 400 and 600°C. The VOC content of the exhaust gas from cement kilns typically lies between 10 and 100 mg/Nm³, in rare cases emissions can reach as much as 500 mg/Nm³ because of the raw material characteristics.

Dioxins and furans

Dioxins and furans are formed while using waste derived fuels (WDF), when chlorine in wastes in the form of precursors such as PVC, NaCl or chlorobenzenes combine with other chemicals at low temperatures. The formation of dioxins occurs only in the presence of a precursor and under reducing conditions when incomplete combustion takes place.

It has been reported that dioxin and furan emission concentrations are low regardless of the type of fuel used and measurements carried out by VDZ (German Cement Industry) showed that cement kilns can comply with an emission level of 0.1 TEQ/Nm³, which is the limit prescribed for hazardous waste incineration plants as per European countries' legislations.

Heavy metals and other air pollutants

The transfer behaviour of heavy metals in cement manufacturing process depends on their volatility, and is generated from the use of raw materials, fossil fuels, and WDF. Metal compounds can be categorized into three classes, based on the volatilities of the metals and their salts:

- Metals which are or have compounds that are refractory or non- or low-volatile: Ba, Be, Cr, As, Ni, V, Al, Ti, Ca, Fe, Mn, Cu and Ag;
- Metals that are or have compounds that are semi-volatile: Sb, Cd, Pb, Se, Zn, K and Na;
- Metals that are or have compounds that are volatile: Hg and Tl.

Low-volatile heavy metals tend to become incorporated in very stable chemical compounds in the clinker. However, concern has been expressed about presence of Nickel and Vanadium in stack emissions, when pet-coke is used as fuel. Semi-low volatile heavy metals tend to volatilize in the hottest section of the kiln i.e., burning zone. These are only partly integrated into the clinker. They condense at lower temperatures on the dust particles, which are removed from the gas stream in the dust collector. Only Mercury is volatile enough to remain in the vapour phase in significant amount. Presence of chlorine can cause some heavy metals to volatilize at far lower temperatures than normal. In such cases, higher proportion of metals leaves the kiln through the stack and they are not controlled through use of filters.

The experience in European Cement Industries, particularly Germany, emphasises that the conditions prevailing during clinker burning process, in contrast to dedicated

incineration plants, constitutes a material conversion process, and ensure low concentrations of trace elements in the exhaust gas. Emission concentrations produced during the use of alternate fuels are mostly considerably lower than limits specified in German 17. BImSch V (Schneider, VDZ, 2000). According to them, the heavy metal input induced by alternative fuels does not become relevant until levels are significantly higher than those observed at the present time. Mercury is the only element that may require input to be limited in individual cases.

Wastewater

Wastewater in cement plants results mainly from surface run off and utility operations for cooling purposes in different phases of the process (e.g., bearings, kiln rings) and causes no substantial contribution to water pollution. Process wastewater with high pH and suspended solids may be generated in some operations. The storage and handling of fuels is a potential source of contamination of soil and groundwater. Stormwater flowing through pet-coke, coal, and waste material stockpiles exposed to the open air may become contaminated.

Solid wastes

Sources of solid waste in cement manufacturing include clinker production waste, mainly composed of spoil rocks, which are removed from the raw materials during the raw meal preparation. Another potential waste stream involves the kiln dust removed from the bypass flow and the stack, if it is not recycled in the process.

Filtrate from the filter presses used in the semi-wet process is fairly alkaline and contains suspended solids.

Limited waste is generated from plant maintenance (e.g., used oil and scrap metal). Other waste materials may include alkali or chloride / fluoride containing dust buildup from the kiln.

Noise

Noise pollution is related to several cement manufacturing phases, including raw material extraction; grinding and storage; raw material, intermediate and final product handling and transportation; and operation of exhaust fans.

Vibration

Mining activities, especially use of explosives for blasting give rise to ground vibration and fly rocks. Suitable buffer zones, at least 300m from the site of blast is recommended.

Odour

Odour emissions are very rarely a problem with a well operated plant. If the raw material contains combustible components (kerogens) which do not burn when they are heated in the preheater, but instead only pyrolise, emissions of hydrocarbons can occur. This hydrocarbon emission can be seen above the stack as a 'blue haze' or plume and can cause unpleasant smell around the cement plant under unfavourable weather conditions.

Burning of sulphur containing fuels and/or use of sulphur containing raw materials can lead to odour emissions (a problem especially encountered in shaft kilns).

3.3 Technological Aspects

3.3.1 Natural resource conservation

3.3.1.1 Use of industrial solid wastes in cement manufacturing

The cement plant has potential to utilize the industrial solid wastes like fly ash and slag as additives to produce fly ash pozzolana cement, and slag cement. On one hand, this technology of reuse of waste material will conserve natural resources of limestone and on the other hand, it will solve the problem associated with disposal of waste material. As per BIS specifications, Portland pozzolana cement (PPC) and Portland slag cement (PSC) can be used interchangeably with ordinary Portland cement (OPC) for most of the constructions.

The list of industrial solid wastes suitable for utilization in cement manufacturing, their compatibility and constraints as raw material/blending material/ admixture are given in the table below:

Table 3-12: Industrial Wastes Suitable for Use as Raw Material

Industrial Waste	Remarks
Fly Ash	R&D investigations have revealed that fly ash up to 3 % can be used as raw mix component for the manufacture of cement clinker. This has already been adopted in some cement plants in India.
Steel slag	Studies have revealed that steel slag can be used up to 10 % as a raw mix component for the manufacturer of cement clinker.
Red mud	R&D investigations have established that 5 % Red mud can be gainfully utilized as raw mix component in the manufacture of cement clinker. The presence of high percentage of alkalis (3 to 4 %) and TiO ₂ (about 12.0 %) restricts its bulk utilization.
Paper Sludge, Carbide sludge, sugar sludge, Chrome sludge	R&D Investigations on the utilization of various lime sludges can be utilized as a component of raw mix, either as partial or total replacement of mined limestone, for the manufacture of Portland cement clinker. The amount depends upon the various impurities that may be present. Disposal in wet form presents difficulty in use in dry process plants. In the past, at least one cement plant was operating on use of carbide sludge as raw material.
Phospho chalk	R&D investigations have established that Phospho-chalk can be used as a raw mix component to 8 % for the manufacture of cement clinker. Presence of impurities viz P ₂ O ₅ , and SO ₃ restricts its level of utilization.
Chrome sludge	Chrome sludge can be used as mineraliser. Presence of chromium oxide (Cr ₂ O ₃) up to 10 % as impurity restricts its bulk utilization.
Lead zinc slag	Lead-zinc slag waste was found suitable as a component in the raw mix for making OPC-clinker up to 6 % only, as it contains high iron-oxide (~40 %).
Phosphorous furnace slag	Up to 10 % phosphorous-furnace slag can be gainfully utilized as raw mix component in making OPC-clinker.

Industrial Waste	Remarks
Kimberlite waste	Kimberlite can be used up to 10 % only as a component of cement raw mix in making OPC-clinker as it contains high MgO (up to 30 %) and SiO ₂ (up to 40 %).
Mine rejects	Depending on the composition, the mine rejects can be used as the component of the raw mix singly or in combination with other admixtures for the manufacture of cement clinker.

Source: CPCB PROBES

Table 3-13: Industrial Wastes Suitable for Use as Blending Material

Industrial waste	Remarks (as extracted from CPCB publication)
Fly ash	Can be used as a blending material for the manufacture of Portland Pozzolona Cement (PPC) in the proportion of 15 to 35 % depending on the quality of fly ash and clinker. The quality of fly ash could be used for the manufacture of PPC should conform to the Indian Standard Specification IS: 3812-Part I-2003.
Granulated blast furnace slag	Granulated blast furnace slag can be used as a blending material in the proportion of 25 to 70 % in the manufacture of Portland Slag cement (PSC) depending upon the quality of slag and clinker used. The quality of the granulated slag, which could be used for the manufacture of PSC, should conform to the Indian Standard Specification IS: 12089-1987.
Lime sludge	The lime sludge from paper industry has been found suitable as blending material for manufacture of masonry cement in the proportion of up to 30 % conforming the Indian Standard specification of IS:3466-1988.
Lead-Zinc slag	R&D investigations have revealed that lead-zinc slag can be used up to 40 % as blending material for making Portland Slag Cement (PSC) conforming to the requirements of IS: 455-1989. The slag does not conform to the requirements of slag to be used for the manufacture of PSC i.e., IS: 12089-1987 w.r.t. IR and glass content and its use is yet to be permitted in BIS specifications.
Phosphorous furnace slag	The granulated phosphorus furnace slag conforming to Indian Standard Specification IS: 12089-1987 can be used as a blending material for the manufacture of PSC in the proportion of 25 to 70 %.
Phospho gypsum	Phospho gypsum is being used as set controller in cement. It contains deleterious constituents like P ₂ O ₅ , F- and free acid. These impurities affect the performance in cement. It can however, be used after beneficiation without any hindrance. In small amounts, Phospho-gypsum can also be used as mineraliser in the raw mix.
Jerosite	It has a potential to be used as a set-controller in cement manufacture due to considerable amount (up to 30 %) SO ₃ content. Detailed investigations are needed, particularly because of the presence of deleterious constituent viz ammonia, before it is considered as a set retarder in the manufacture of cement.

Source: CPCB PROBES

The use of suitable wastes as raw materials can reduce the input of natural resources, but should always be done with satisfactory control on the substances introduced to the kiln process.

3.3.1.2 Use of high calorific value wastes as fuel in cement kiln

Some hazardous combustible wastes (HCW) may be consumed in the cement kiln as fuels. Cement kilns have a combustion regime, where the temperature (>1400 °C) is higher than in HCW incinerators, the residence time is longer and alkaline nature of the raw materials provides a treatment for acidic gases. Co-processing of HCW in a cement kiln is a better alternative than incinerators, landfill or dumping. It can provide an integral solution to waste management for safe disposal of HCW, without requiring any additional facility for hazardous waste disposal. For the cement manufacture, it helps in substituting fossil fuels and curtails energy costs. Alternative fuels can frequently contain impurities like phosphates, chlorine, heavy metals, *etc.* Interaction of the flue gases and the raw material present in the kiln ensures that the non-combustible part of the residue is held back in the process and is incorporated into the clinker in a practically irreversible manner.

In general, broadly there are three options for feeding the alternative fuels with or without modification: the main burner, the inlet chamber, and the calciner (including special burning chambers). A list of waste derived fuels suitable for Indian conditions is, along with their calorific value and possible utilization area is given in Table 3 – 14 below.

Table 3-14: Waste Derived Fuels Suitable in Cement Manufacture

Type	Net Calorific value, kJ/kg	Utilization area
Municipal WDF		
Domestic Refuse	8,500	Calciner
Mixed plastics	19,000 – 46,000	Main burner /Calciner
Waste tyres, shredder/complete	28,000 – 32,000	Calciner / Inlet chamber / Burning module
Dried sewage sludge	7,500	Main burner / Calciner
Industrial WDF		
Waste oils (Refinery)	30,000 – 40,000	Main burner / Calciner
Paper Pulp	15,000	Main burner / Calciner
Pot liners (Alumina smelters)	20,000	Calciner
Agricultural WDF		
Rice Husk	16,000	Main burner / Calciner
Palm nut shells	19,000	Inlet chamber
Saw dust	10,000 – 13,000	Main burner / Calciner

Source: 10th NCB International Seminar, 2007

CPCB, on the basis of field trials, have recommended use of hazardous wastes like ETP sludge from dyes and dye intermediates, tyre chips, paint sludge, Toulene-Die-Isocynate tar residue and refinery sludge as supplementary fuels in cement kilns. Compliance with notified emission norms for hazardous wastes in incinerators has been reported.

Cement plants are traditionally designed for burning pulverised fuels with particle sizes generally smaller than 0.1 mm, which burn out within 10 sec of residence time. Alternative fuels in shredded or bulk form generally have much larger particle sizes,

which require greater burning time. Sensitivity of combustion rates to O₂ concentration and temperature are different in case of WDFs than in usual fossil fuels. The alternate fuels, therefore, have to be injected in such locations, where the temperature is sufficiently high to ensure complete burning and destruction of organic compounds. Mainly, liquid WDFs like waste oils, comminuted plastics or paper pulp are introduced via the main burner. The inlet chamber is mostly used for feeding complete tyres or lumpy material. The most flexible location for use of WDFs is the calciner, as sufficient oxygen is available. On one hand, the temperature and oxygen levels in the calciner streams are required to be kept as low as possible for reducing heat consumption, a complete burnout of the WDF is to be ensured to avoid CO-triggered failures. Secondary fuels with problematic combustion properties must be given sufficient retention time to burn out. Extended calciner residence time has to be provided. Process considerations are important in order to maintain clinker quality, kiln system availability low emissions, *etc.* All these should receive due consideration in calciner and burner design.

Use of waste fuel or waste raw material in cement manufacturing requires a specific permit from the local authority. The permit should specify the amounts and types of waste that may be used either as fuel or as raw material, and it should also include quality standards such as minimum calorific value and maximum concentration levels of specific pollutants, such as PCB, chlorine, PAH, mercury, and other heavy metals.

Waste minimization opportunities

The dust collected in pollution control devices is a valuable material. Recycling of collected dust to the production processes lowers the total consumption of raw materials. This recycling may take place directly in the kiln or kiln feed (alkali metal content being the limiting factor) or by blending with finished cement products.

The best available techniques for reducing dust emissions are the combination of the following:

- Minimization/prevention of dust emissions from fugitive sources
- Efficient removal of particulate matter from point sources by application of Electrostatic precipitators with fast measuring and control equipment to minimize the number of CO trips
- Fabric filters with multiple compartments and ‘burst bag detectors’

3.3.1.3 Process selection

The selected process will affect the releases of all pollutants, and will also have a significant effect on the energy use. For new plants and major upgrades a dry process kiln with multi-stage preheating and precalcination is considered to be state of the art. The wet process kilns operating in India are generally expected to convert to the dry process when renewed, and so are semi-dry and semi-wet processes.

- Energy efficiency improvement options
- Conversion of wet process plants to dry process
- 5-6 stage pre heaters with low pressure drop cyclones
- Co-generation of power utilizing waste heat (for large dry process plants)
- Close circuit grinding
- Use of vertical roller mills
- Use of high pressure grinding rolls
- Use of high efficiency separators, static – dynamic separators

- Use of gyratory crushers and mobile crushers
- Use of high efficiency fans
- Adoption of efficient material conveying system *e.g.*, bucket elevators and dense phase pneumatic conveying
- Improved mill internals (*e.g.*, flow control diaphragms with lifters, high chrome grinding media)
- Adoption of on line coal quality modulation system
- Usage of washed coal
- Utilization of alternate fuels like natural gas, lignite and waste fuel.
- Reduction in false air infiltration
- Manufacture of blended cements
- Process optimization *e.g.*, automatic control and expert systems, upgrading refractory practices, optimized raw mix proportioning, *etc.*
- Maintenance management *i.e.*, better preventive maintenance including condition monitoring.

3.3.1.4 General techniques

Process control optimization

Optimization of the clinker burning process is usually done to reduce the heat consumption, to improve the clinker quality and to increase the lifetime of the equipment (the refractory lining, for example) by stabilizing process parameters. Reduction of emissions, such as NO_x, SO₂ and dust, are secondary effects of this optimization. Smooth and stable kiln operation close to design values for process parameters is beneficial for all kiln emissions. Optimisation includes measures like homogenizing the raw material, ensuring uniform coal dosing and improving the cooler's operation. To ensure that the feed rate of solid fuel is steady with minimal peaks, it is essential to have good designs of hopper, transport conveyor and feeder, such as a modern, gravimetric solid fuel feed system. NO_x reduction is caused by the reduced flame and burning temperatures and the reduced consumption of fuel, as well as zones with a reducing atmosphere in the kiln system. Control of oxygen content (excess air) is critical to NO_x control. Generally the lower the oxygen content (excess air) at a cement kiln backend, the less NO_x is produced. However, this has to be balanced against increases in CO and SO₂ at lower oxygen levels. NO_x reductions of up to 30% have been reported. The SO₂ reduction is caused by the reduced SO₂ volatility at lower flame and burning temperatures and the oxidizing atmosphere in the kiln, together with stable kiln operation. The effect of kiln optimization on SO₂ emission is considerable for long wet and dry kilns and marginal for preheater kilns. SO₂ reductions of up to 50% have been reported. Avoidance of kiln upsets and of CO-trips when EPs are applied, reduces dust emissions, and in doing so, also reduces emissions of any substances adsorbed to the dust for example metals. Modern control systems with faster measuring and control equipment can allow higher switch off criteria than the typically applied 0.5% v/v CO, and thereby reduce the number of CO-trips. Kiln optimization is applicable to all kilns and can include many elements ranging from instruction/training of the kiln operators up to installation of new equipment such as dosing systems, homogenization silos, preblending beds and new clinker coolers. Several cement equipment suppliers have developed expert automatic control systems based usually on the control of the burn by monitoring NO_x levels. Kiln optimization is primarily done to reduce operating costs, increase capacity and improve product quality. The operating cost of an optimized kiln is usually reduced compared to the non-optimized state. The savings result from reduced fuel and refractory consumption, lower maintenance cost and higher productivity among other factors.

Choice of fuel and raw material

Careful selection and control of substances entering the kiln can reduce emissions. For example, limiting the sulphur content of both raw materials and fuels can reduce releases of SO₂. The same is valid for raw materials and fuels containing other substances, for *e.g.* nitrogen, metals and organic compounds. There are, however, some differences between different kiln systems and feeding points. For *e.g.* fuel sulphur is not a problem for dry preheater and pre-calciner kiln systems, and all organic compounds in fuels fed through the main burner will be completely destroyed. Limiting the chlorine content of input materials reduces formation of alkaline chlorides (and other metal chlorides), which can cause build-ups and upset kiln conditions and therefore can impair the performance of electrostatic precipitators, which in turn causes increased dust emissions. High alkali materials may also require some of the dust to be bled off, rather than be recycled within the kiln system, to avoid high alkali contents in the final product. In this case, use of low alkali materials can allow the dust to be returned to the process, thus reducing the waste generated by the process.

3.3.1.5 Techniques for controlling dust emissions

Dust is the major pollutant emitted in the process of production of cement. The dust generation occurs from various sections of the cement plant during the process of cement manufacturing. The source of emission includes both point source and fugitive emission. The air quality in and around the plants is predominantly polluted by suspended particulate matter which can affect the surroundings.

Control from point sources

For particulate matter emissions associated with the operation of kiln systems, clinker coolers, and mills, including clinker and limestone burning, the following pollution prevention and control techniques, in addition to proper smoothing of kiln operations, are recommended:

- Capturing kiln and cooler dusts using filters and recycling the recovered particulates into the kiln feed and into the clinker, respectively
- Using electrostatic precipitators (ESPs) or fabric filter systems (baghouses) to collect and control fine particulate emissions in kiln gases
- Using cyclones to separate large particulates of cooler gases, followed by fabric filters
- Capturing mill dust by fabric filters and recycling within the mill.

The dust control equipment recommended for different sections are given in the Table below.

Table 3-15: Recommended Dust Control Equipments for Different Sectors

Section	Dust Collector
Crusher	Bag Filter
Raw Mill	Bag Filter/ESP
Kiln	Glass Bag House/ Bag Filter/ESP with GCT
Clinker Cooler	ESP/Bag Filter with heat exchanger

Section	Dust Collector
Coal Mill	Bag Filter/ESP
Cement Mill	Bag Filter/ESP
Packing Plant	Bag Filter
Source: CPCB	

Table 3-16: Salient Features of Dust Collectors

Parameter	Dust Collectors			
	Cyclone/ Multi Cyclone	Fabric Filter	ESP	Gravel Bed Filter
Efficiency (%)	80-95	99.99	99.99	99.99
Pressure drop (mmWG)	150	150	25	150
Cut diameter (µm)	3-10	0.5	0.1-0.8	0.5-2. 5
Capital cost	Low	High	Very high	Moderate
Operating cost	Low	Moderate	Low	Moderate
Maintenance	Nil	Periodic	Periodic	Tedious
Secondary pollution	Nil	Nil	Nil	Nil
Particle size (µm) collection	20	Submicron	Submicron	1
Operating temperature (°C)	Very high	260	150	400

Fugitive dust control

For PM emissions associated with intermediate and final materials handling and storage (including crushing and grinding of raw materials); handling and storage of solid fuels; transportation of materials (e.g., by trucks or conveyor belts), and bagging activities, the recommended pollution prevention and control techniques include the following:

- Local exhaust ventilation system, enclosures, hoods
- Water spray system
- Green cover, tree plantation
- Wind barriers
- Proper house keeping

The fugitive dust control methods appropriate for various sections in a cement plant are given below:

Table 3-17: Methods of Fugitive Dust Control

Control Techniques								
Fugitive Emission Sources	Planting/ Vegetative Cover	Paving Gravel	Wind Barriers	Sweeping & Cleaning	Enclosure	Hood and Ducting	Reducing Drop Height	Water Spray
Crusher discharge					X	X	X	X

Control Techniques								
Fugitive Emission Sources	Planting/ Vegetative Cover	Paving Gravel	Wind Barriers	Sweeping & Cleaning	Enclosure	Hood and Ducting	Reducing Drop Height	Water Spray
Screening					X	X	X	X
Conveyor transfer points					X	X	X	X
Discharge to and from hoppers					X	X	X	
Silos and bins						X	X	
Stack cleaning						X	X	
Loading and unloading			X					
Paved roads			X	X				
Unpaved roads	X	X	X					
Open storage piles	X		X				X	X
Construction sites		X	X					
Exposed areas	X	X	X	X				

The guidelines evolved by CPCB (attached as **Annexure I**) should be adopted for prevention and control of fugitive emissions from cement plants.

3.3.1.6 Control techniques for gaseous pollutants

Nitrogen oxides

Nitrogen oxide (NO_x) emissions (Nitrogen monoxide represents more than 90 % of NO_x emitted) are generated in the high temperature combustion process of the cement kiln. The following prevention and control techniques, in addition to proper smoothing of kiln operations, are recommended:

- Maintaining stable operating conditions *i.e.*, constant fuel, air, feed flow rates and composition by installing an automatic kiln control system.
- Using low NO_x burners to avoid localized emission hot spots;

- Developing a staged combustion process, as applicable in preheater-precalciner (PHP) and preheater (PH) kilns; zero – NO_x precalciners,
- Use of selective non catalytic NO reduction (SNCR) and selective catalytic reduction (SCR) measures.

Sulphur dioxide

Recommended pollution control techniques for reduction of SO₂, in addition to proper smoothing of kiln operations, include the following:

- Use of a vertical mill and gases passing through the mill to recover energy and to reduce the sulphur content in the gas. In the mill, the gas containing sulphur oxide mixes with the calcium carbonate (CaCO₃) of the raw meal and produces calcium sulfate (gypsum)
- Selection of fuel source with lower sulphur content
- Injection of absorbents such as hydrated lime (Ca(OH)₂), calcium oxide (CaO), or fly ashes with high CaO content into the exhaust gas before filters
- Use of wet or dry scrubbers. (Dry scrubbing is a more expensive and therefore less common technique than wet scrubbing and is typically used when the SO₂ emissions have the potential to be higher than 1500 mg/Nm³)

Carbon dioxide

CO₂ emissions can be reduced by adopting the following measures:

- Improvement of the energy efficiency of cement production
- Shifting to a more energy efficient process [*e.g.*, from wet & semi dry to dry process]
- Process selection and operation to promote energy efficiency (dry/ pre-heater/ pre-calciner);
- Applying lower clinker/cement ratio *i.e.*, increasing additives / cement ratio
- Removal/recovery of CO₂ from the flue gases
- Selection of raw materials with lower organic matter content
- Increased afforestation and sink potential for CO₂
- Recovery of waste heat for cogeneration of power
- Optimizing particle size distribution of fine coal
- Use of alternate fuel (oil, gas)/waste derived *i.e.*, replacing high carbon fuels by low carbon fuels. *e.g.*, coal may be replaced by oil, natural gas, waste derived fuel

3.3.1.7 Other air pollutants

Heavy metals

Recommended techniques to limit emissions of heavy metals include the following:

- For high concentrations of volatile heavy metals (in particular mercury), use of absorption on activated carbon may be necessary. The resulting solid waste should be managed as a hazardous waste
- Implement monitoring and control of the volatile heavy metal content in the input materials and waste fuels through implementation of materials selection. Depending on the type of volatile metals present in the flue gas, control options may include wet scrubbers and activated carbon adsorption

- Operate the kiln in a controlled and steady manner to avoid emergency shutoffs of the electrostatic precipitators
- Waste fuel should not be used during start up or shut down

Dioxin emission control at cement kilns

Change of raw materials has been the successful remedy to prevent dioxin and furan emissions from some plants, but it is not universally acceptable since proposed alternates are also not free from dioxin precursor. Temperature control at the inlet of Air Pollution Control Devices (APCD) may be an alternative to prevent dioxin emissions. There is an inverse exponential between dioxin emission and APCD inlet temperature. Proper design and maintenance can lower the temperature of flue gas. Additional water spraying and air quenching may be installed for further control of temperature to prevent reformation of dioxin.

Recently few other control options for dioxin have been established but these are too expensive and problematic to implement. Gore bags (Remedial catalytic filter system) actually destroy the dioxin as the exhaust gases are simultaneously cleaned of particulates. This system is reportedly reducing considerable dioxin emissions (more than 90%).

3.3.1.8 Noise

Control of noise emissions may include the use of silencers for fans, room enclosures for mill operators, noise barriers.

3.3.1.9 Wastewater

Contaminated streams should be routed to the treatment system for industrial process wastewater. Stormwater should be prevented from contacting stockpiles by covering or enclosing stockpiles and by installing run-on controls. Recommended pollution prevention techniques for dust emissions from stockpiles of raw materials, clinker, coal, and waste (as above) may also help to minimize contamination of stormwater. If stormwater does contact stockpiles, soil and groundwater should be protected from potential contamination by paving or otherwise lining the base of the stockpiles, installing run-off controls around them and collecting the stormwater in a lined basin to allow particulate matter to settle before separation, control, and recycling or discharge.

3.3.1.10 Solid waste

Collected dust should be recycled to the production processes whenever practicable. This recycling may take place directly into the kiln or kiln feed (alkali metal content being the limiting factor) or by blending with finished cement products. Alternative ways of usage may be found for material that cannot be recycled.

3.3.1.11 Risk & safety

The most significant occupational health and safety impacts occur during the operational phase of cement projects and primarily include the following:

- Dust
- Heat

- Noise and vibrations
- Physical hazards
- Radiation
- Chemical hazards and other industrial hygiene issues

Dust

Exposure to fine particulates is associated with work in most of the dust-generating stages of cement manufacturing, but most notably from quarry operation, raw material handling, and clinker / cement grinding. Exposure to active (crystalline) silica dust (SiO_2), when present in the raw materials, is a relevant potential hazard in the cement and lime manufacturing sector. Methods to prevent and control exposure to dust include the following:

- Control of dust through implementation of good housekeeping and maintenance
- Use of air-conditioned, closed cabins
- Use of dust extraction and recycling systems to remove dust from work areas, especially in grinding mills
- Use of air ventilation (suction) in cement-bagging areas
- Use of PPE, as appropriate (*e.g.*, masks and respirators) to address residual exposures following adoption of the above-referenced process and engineering controls
- Use of mobile vacuum cleaning systems to prevent dust buildup on paved areas

Heat

The principal exposures to heat in this sector occur during operation and maintenance of kilns or other hot equipment. Recommended prevention and control techniques include the following:

- Shielding surfaces where workers' proximity and close contact with hot equipment is expected, using personal protective equipment (PPE), as needed (*e.g.*, insulated gloves and shoes)
- Minimizing the work time required in high temperature environments by implementing shorter shifts at these locations
- Making available and using, as needed, air-or oxygen supplied respirators
- Implementing specific personal protection safety procedures in the lime-hydrating process to avoid potential exposure to exothermic reactions

Noise and vibrations

Exhaust fans and grinding mills are the main sources of noise and vibrations in cement and lime plants. Control of noise emissions may include the use of silencers for fans, room enclosures for mill operators, noise barriers, and, if noise cannot be reduced to acceptable levels, adopt personal hearing protection.

Physical hazards

Injuries during cement manufacturing operations are typically related to slips, trips, and falls; contact with falling /moving objects; and lifting / over-exertion. Other injuries may occur due to contact with, or stuck in, moving machinery (*e.g.*, dump trucks, front loaders, forklifts). Activities related to maintenance of equipment, including crushers,

mills, fans, coolers, and belt conveyors, represent a significant source of exposure to physical hazards

Radiation

An X-ray station is sometimes used to continuously monitor the raw material mix on the belt conveyor feeding the raw mill. Operators of this equipment should be protected through the implementation of ionizing radiation protection measures

Chemical hazards and other industrial hygiene issues

Chromium may contribute to allergic contact dermatitis among workers handling cement. Prevention and control of this potential hazard includes a reduction in the proportion of soluble chromium in cement mixes and the use of proper personal protective equipment (PPE) to prevent dermal contact.

3.3.1.12 Monitoring

To control kiln process, continuous measurements are recommended for the following parameters:

- pressure
- temperature
- O₂-content
- NO_x, CO₂
- CO, and possibly when the SO_x concentration is high
- SO₂ (it is a developing technique to optimize CO with NO_x and SO₂)

To accurately quantify the emissions, continuous measurements are recommended for the following parameters (these may need to be measured again if their levels can change after the point where they are measured to be used for control):

- exhaust volume (can be calculated but is regarded by some to be complicated)
- humidity (can be calculated but is regarded by some to be complicated)
- temperature
- dust
- O₂
- NO_x
- SO₂ and
- CO

Regular periodical monitoring is appropriate to carry out for the following substances:

- metals and their compounds
- TOC
- HCl
- HF
- NH₃, and
- PCDD/Fs

Measurements of the following substances may be required occasionally under special operating conditions:

- BTX (benzene, toluene, xylene),
- PAH (polyaromatic hydrocarbons), and
- Other organic pollutants (for *e.g.*, chlorobenzenes, PCB (polychlorinated biphenyls) including coplanar congeners, chloronaphthalenes, *etc.*)

It is especially important to measure metals when wastes with enhanced metals contents are used as raw materials or fuels.

3.4 Summary of Applicable National Regulations

3.4.1 General description of major statutes

A compilation of legal instruments which are applicable to cement industries is annexed as **Annexure II**.

3.4.2 General standards for discharge of environmental pollutants

List of general standards for discharge of environmental pollutants as per CPCB is given in **Annexure III**.

3.4.3 Industry-specific requirements

Emission standards for cement plant

Considering the contribution of air pollution by the cement plants, the CPCB in close consultation with the SPCB and the association of cement industry had evolved emission standards for cement plants of different capacities and with different vintage, which are given below:

1. Existing cement plants

Plant Capacity	Emission standards for particulate matter (mg/Nm ³)	
	Protected area	Other area
200 TPD and less (All Sections)	250	400
Greater than 200 TPD (All Sections)	150	250

Note:

The CPCB and SPCB may fix stringent standards not exceeding 250 mg/Nm³ for smaller plants and 150 mg/Nm³ for larger plant if the industry is located in an area which, in their opinion, requires more stringent standards.

Where continuous monitoring equipments are provided on dust emission lines the integrated average values over a period, to be fixed by the central and state boards but not exceeding 72 hours shall be considered instead of momentary dust emission value conformity to standards.

For Cement Plants, including grinding units, located in critically polluted or urban areas with a population of one lakh and above (including 5 Km distance outside urban boundary):

Particulate matter - 100mg/Nm³

2. New cement plants

For New Cement Kilns, including grinding units to be installed:

Particulate Matter - 50 mg/Nm³

Guidelines for control of fugitive emissions

The CPCB has also formulated some guidelines for control of fugitive emissions from different sources and the same has been circulated among SPCBs and Industry Association for Implementation. Guidelines are attached as **Annexure I**.

Policy on use of high calorific value hazardous wastes

The CPCB has conducted trial runs for “Coincineration of high calorific value hazardous wastes as fuel in cement kilns of Indian industries”. Based on the outcome of the results, a policy has been prepared by the CPCB and the same has been approved by the MoEF. The policy has been circulated among all stakeholders for necessary action.

Other requirements

For SO₂ and NO_x, no emission limits are specified in India so far.

3.4.4 Pending and proposed regulatory requirements

Following are some of the Charter on Corporate Responsibility for Environmental Protection (CREP) action points which need to be implemented.

- Non-complying cement industries, which require augmentation of the existing air pollution control device (APCD) or replacement of existing APCD have to comply with the emission standards.
- Keeping in view the formation of NO_x at high temperature of kiln, the CPCB will also evolve the standards for SO₂ and NO_x emission. These limits can be in line with other countries, where such limits applicable for cement industry are in force (Table 3-18).

Table 3-18: NO_x and SO_x Emissions Limits for Cement Industry in force

Country	Emission Limits, mg/Nm ³	
	NO _x	SO ₂
Sweden	200	200
Australia	500	200
Austria	500	200
Germany	500	400

UK	500	400
Switzerland	800	400
Portugal	800	400

- All necessary measures need to be taken by cement industries to control fugitive dust emission. Monitoring data should be submitted to CPCB/SPCB regularly.
- Use of Pet-coke as fuel in cement kiln is likely to cause higher SO₂ emission besides other toxic metal emission like Ni and V. Although there is in-built desulphurisation mechanism in cement manufacturing, it may be examined by the CPCB, NCB, BIS and Oil refineries whether any further safeguard is required on the use of petroleum coke as fuel in cement kiln.
- Industries themselves have to ensure that emission is not exceeding the standards, at any time. Therefore, industries should install continuous online stack monitoring system with data logging system for particulate matter at raw mill, kiln, clinker cooler, cement mill and coal mill. This will also help the industries in defending themselves in case of complaints.
- Industries have to set their target to enhance waste material utilization.

Proposed regulatory requirements

The CPCB has proposed a policy on use of high calorific value hazardous wastes as a fuel in cement kilns of Indian industries, for which the MoEF has given its consent.

4. OPERATIONAL ASPECTS OF EIA

Prior environmental clearance process has been revised in the Notification issued on 14th September, 2006, into following four major stages i.e., screening, scoping, public consultation and appraisal. Each stage has certain procedures to be followed. This section deals with all the procedural and technical guidance, for conducting objective-oriented EIA studies, their review and decision-making. Besides, the Notification also classifies projects into Category A, which requires prior environmental clearance from MoEF and Category B from SEIAA/UTEIAA.

Consistency with other requirements

- Clearance from other regulatory bodies is not a pre-requisite for obtaining the prior environmental clearance and all such clearances will be treated as parallel statutory requirements.
- Consent for Establishment (CFE) and Prior Environmental Clearance are two different legal requirements, a project proponent should acquire. Therefore, these two activities can be initiated and proceeded with simultaneously.
- If a project falls within the purview of CRZ and EIA Notifications, then the project proponent is required to take separate clearances from the concerned Authorities.
- Rehabilitation and Resettlement (R&R) issues need not be dealt under the EIA Notification as other statutory bodies deal with these issues. However, socio-economic studies may be considered while taking environmental decisions.

4.1 Coverage of Cement Plants under the Purview of Notification

All new cement industrial projects including expansion and modernization require prior environmental clearance. Based on pollution potential, these projects are classified into Category A and Category B *i.e.*,

- Category A: all projects having equal to or greater than 1 million tonnes per annum production capacity
- Category B: all projects having less than 1 million tonnes per annum production capacity

Besides there are general conditions, when it applies, a Category B project will be treated as Category A project. These conditions are discussed in subsequent sections.

The sequence of steps in the process of prior environmental clearance for Category A projects and the Category B projects are shown in Figure 4.1 and Figure 4.2 respectively. Each stage in the process of prior environmental clearance for the cement industries are discussed in subsequent sections. The timelines indicated against each stage are the maximum permissible time lines set in the Notification for said task. In case the said task is not cleared/objected by the concerned Authority, within the specified time, said task is deemed to be cleared, in accordance to the proposal submitted by the proponent.

In case of Expansion or Modernization of the developmental Activity:

- Any developmental activity, which has an EIA clearance (existing plant), when undergoes expansion or modernization (change in process or technology) with increase in production capacity or any change in product mix beyond the list of products cleared in the issued clearance is required to submit new application for EIA clearance.
- Any developmental activity, which is listed in Schedule of the EIA Notification and due to expansion of its total capacity, if falls under the purview of either Category B or Category A, then such developmental activity requires clearance from respective Authorities.

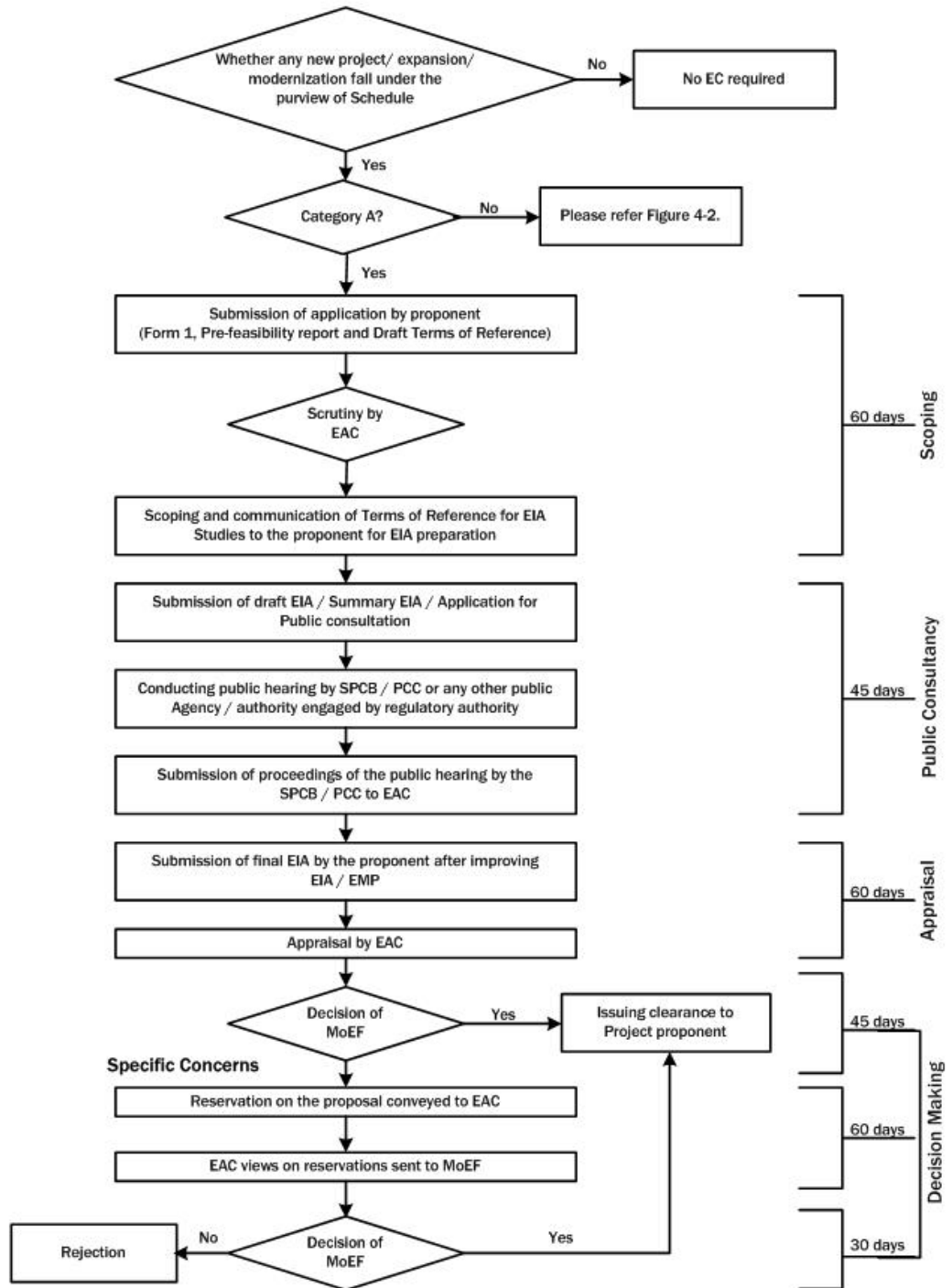

Figure 4-1: Prior Environmental Clearance Process for Activities Falling Under Category A

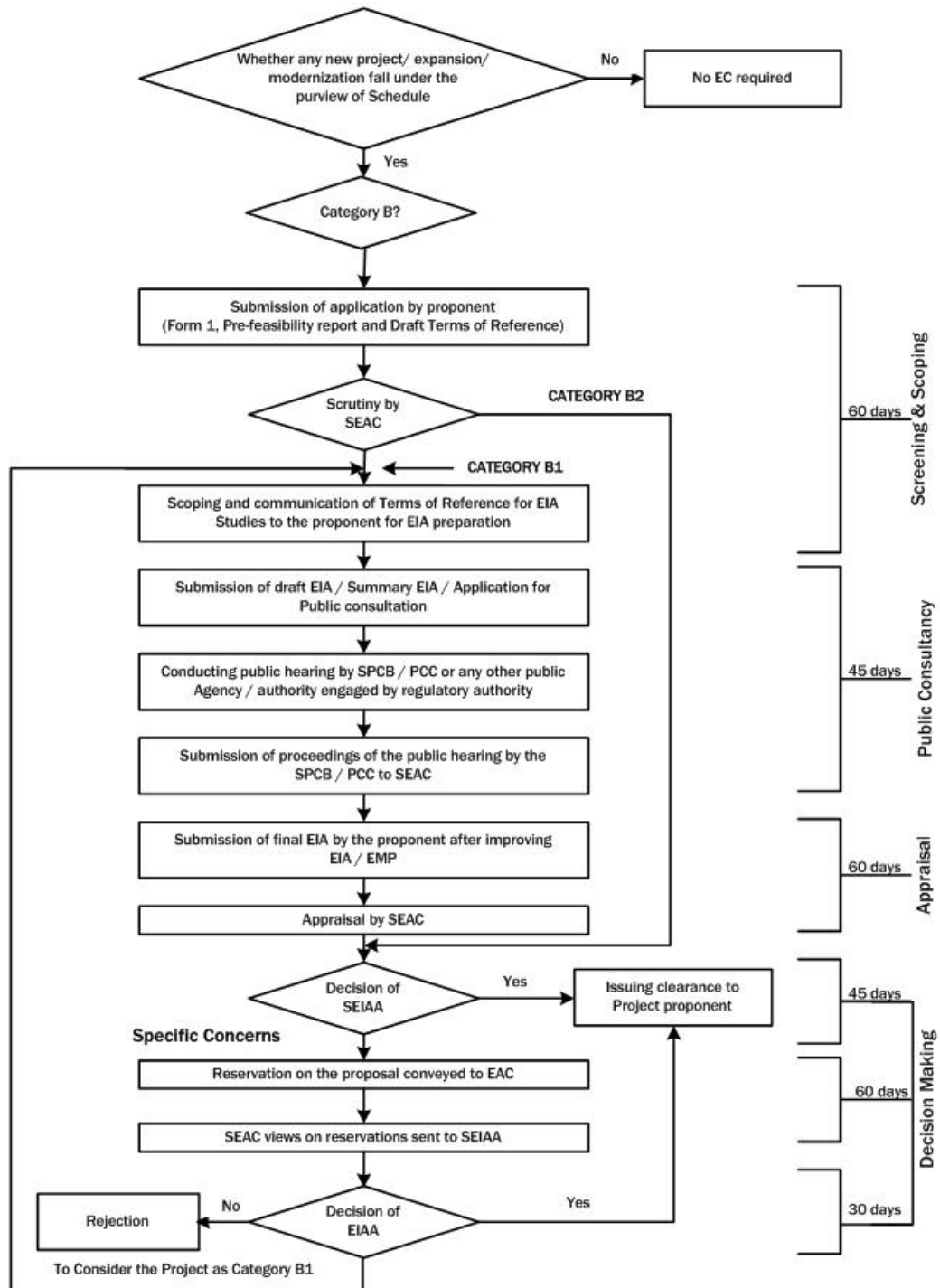

Figure 4-2: Prior Environmental Clearance Process for Activities Falling Under Category B

4.2 Screening

Screening of the project shall be performed at the initial stage of the project development so that proponents are aware of their obligations before deciding on the budget, project design and execution plan.

This stage is applicable only for Category 'B' developmental activity *i.e.*, if general conditions are applicable for a Category B project, then it will be treated as Category A project. Besides, screening also refers to the classification of Category B projects into either Category B1 or Category B2. Category B1 projects require to follow all stages applicable for a Category A project, but are processed at the SEIAA/UTEIAA. Category B2 projects, on the other hand, do not require either EIA or public consultation.

As per the Notification, classification of Category B projects falls under the purview of the SEAC. This manual provides certain guidelines to the stakeholders for classification of Category B1 and Category B2.

4.2.1 Applicable conditions for Category B projects

Generic condition:

- Any cement plant project that has a production capacity of < 1.0 million tonnes/annum (usually falling under Category B) will be treated as Category A, if located in whole, or in part within 10 km from the boundary of:
 - Protected areas notified under the Wild Life (Protection) Act, 1972
 - Critically polluted areas as notified by the CPCB from time to time
 - Eco-sensitive areas as notified under Section 3 of the E(P) Act, 1986, such as Mahabaleshwar Panchgani, Matheran, Panchmarhi, Dahanu, Doon valley
 - Inter-State boundaries and international boundaries – provided the requirement regarding distance of 10 km of the inter-state boundaries can be reduced or completely done away with by an agreement between the respective States/UTs sharing the common boundary
- If any of the conditions listed in above general condition applies, then a Category B project will be treated as Category A.
- Stand-alone grinding units fall in Category B
- The SEIAA shall base its decision on the recommendations of a State/UT level EAC for the purpose of prior environmental clearance.
- In absence of a duly constituted SEIAA or SEAC, a Category B project shall be appraised at the Central level *i.e.*, at the MoEF
- The EAC at the State/UT level shall screen the projects or activities in Category B. SEAC shall meet at least once every month.
- If any Category B cement plant project/activity, after proposed expansion of capacity/production or fuel change, falls under the purview of Category A in terms of production capacity, then clearance is required from the Central Government.

4.2.2 Criteria for classification of Category B1 and B2 projects

The classification of Category B projects or activities into B1 or B2 (except the project or activities listed in item 8(b) in the schedule to the EIA Notification, 2006) will be determined based on whether or not the project or activity requires further environmental

studies for preparation of an EIA for its appraisal prior to the grant of environmental clearance. The necessity of which will be decided, depending upon the nature and location specificity of the project, by SEAC after scrutiny of the applications seeking environmental clearance for Category B projects or activities.

The projects requiring an EIA report shall be included in Category B1 and remaining projects will fall under Category B2 and will not require an EIA report and public consultation.

4.2.3 Application for prior environmental clearance

- The project proponent, after identifying the site and carrying out a pre-feasibility study, is required to apply for the prior environmental clearance using Form 1 given in **Annexure IV**. The proponent has to submit the filled in Form 1 along with the pre-feasibility report and draft ToR for EIA studies to the concerned Authority *i.e.*, MoEF, Government of India for Category A projects and the SEIAA in case of Category B projects. Please refer subsequent sections for the information on how to fill the Form 1, contents of pre-feasibility report and draft ToR for cement plants.
- Prior environmental clearance is required before starting any construction work, or preparation of land on the identified site/project or activity by the project management, except for securing the land.
- If the application is made for a specific developmental activity, which has an inherent area development component as a part of its project proposal and the same project also attracts the construction and area development provisions under 8a and 8b of the Schedule, then the project will be seen as a developmental activity other than 8a and 8b of the Schedule.

4.2.4 Siting guidelines

These are the guidelines, stake holders may consider while siting the developmental projects, to minimize the associated possible environmental impacts. In some situations, adhering to these guidelines is difficult and unwarranted. Therefore these guidelines may be kept in the background, as far as possible, while taking the decisions.

Areas preferably be avoided

While siting industries, care should be taken to minimize the adverse impact of the industries on immediate neighborhood as well as distant places. Some of the natural life sustaining systems and some specific landuses are sensitive to industrial impacts because of the nature and extent of fragility. With a view to protect such sites, the industries may maintain the following distances, as far as possible, from the specific areas listed:

- Ecologically and/or otherwise sensitive areas: Preferably 5 km; depending on the geo-climatic conditions the requisite distance may be decided appropriately by the agency.
- Coastal Areas: Preferably ½ km away from high tide line (HTL).
- Flood Plain of the Riverine System: Preferably ½ km away from flood plain or modified flood plain affected by dam in the upstream or flood control systems.
- Transport/Communication System: Preferably ½ km. away from highway and railway line.

- Major Settlements (3,00,000 population): Distance from major settlements is difficult to maintain because of urban sprawl. At the time of siting of the industry, if the notified limit of any major settlement is found to be within 50 km from the project boundary, the spatial direction of growth of the settlement for at least a decade must be assessed. Subsequently, the industry may be sited at least 25 km from the projected growth boundary of the settlement.
- Critically polluted areas identified by MoEF, from time to time. (Current list of critically polluted areas is given in **Annexure V**)

Note:

Ecological and/or otherwise sensitive areas include (i) Religious and Historic Places; (ii) Archaeological Monuments (e.g. identified zone around TajMahal); (iii) Scenic Areas; (iv) Hill Resorts; (v) Beach Resorts; (vi) Health Resorts; (vii) Coastal Areas rich in Corals, Mangroves, Breeding Grounds of Specific Species; (viii) Estuaries rich in Mangroves, Breeding grounds of Specific Species; (ix) Gulf Areas; (x) Biosphere Reserves; (xi) National Parks and Sanctuaries; (xii) Natural lakes, Swamps; (xiii) Seismic Zones; (xiv) Tribal Settlements; (xv) Areas of Scientific and Geological Interest; (xvi) Defence Installations, specially those of security importance and sensitive to pollution; (xvii) Border Areas (International) and (xviii) Air Ports.

Pre-requisite: State and Central Governments are required to identify such areas on a priority basis.

General siting factors

In any particular selected site, the following factors must also be recognized.

- No forest land shall be converted into non-forest activity for the sustenance of the industry (Ref: Forest Conversation Act, 1980).
- No prime agricultural land shall be converted into industrial site.
- Land acquired shall be sufficiently large to provide space for appropriate green cover including green belt, around the battery limit of the industry.
- Layout of the industry that may come up in the area must conform to the landscape of the area, without affecting the scenic features of that place.
- Associated township of the industry may be created at a space having physiographic barrier between the industry and the township.

4.3 Scoping for EIA Studies

Scoping exercise is taken up soon after the project contours are defined. The primary purpose of scoping is to identify the concerns and issues which may affect the project decisions. Besides, scoping defines the requirements and boundaries of an EIA study.

Scoping refers to the process by which the EAC, in case of Category ‘A’ projects or activities, and SEAC in case of Category ‘B1’ projects, including applications for expansion and/or modernization of existing projects, determine ToR for EIA studies addressing all relevant environmental concerns for preparation of an EIA Report for a particular project.

- Project proponent shall submit application to concerned Authority. The application (Form 1 as given in **Annexure IV**) shall be attached with pre-feasibility report and

proposed ToR for EIA Studies. The proposed sequence to arrive at the draft ToR is discussed below:

- Pre-feasibility report provides a precise summarizes of the project details and also the likely environmental concerns based on secondary information, which will be availed for filling Form 1.
 - From pre-feasibility report and Form 1, valued environmental components (VECs) may be identified for a given project (receiving environment/social components, which are likely to get affected due to the project operations/activities).
 - Once the project details from the pre-feasibility report & Form 1; and VECs are identified, a matrix establishing the interactions which can lead to the effects/impacts could be developed (Qualitative analysis).
 - For each identified possible effect in the matrix, significance analysis could be conducted to identify the impacts, which needs to be studied further (quantitative analysis) in the subsequent EIA studies. All such points will find a mention in the draft ToR to be proposed by the project proponent. The draft ToR shall include applicable baseline parameters (refer annexure VIII) and impact prediction tools proposed to be applied (refer annexure X).
 - The information to be provided in pre-feasibility report, guidelines for filling Form 1 and guidelines for developing draft ToR is summarized in the subsequent sections.
 - Authority consults the respective EAC/SEAC to reply to the proponent. The EAC/SEAC concerned reviews the application form, pre-feasibility report and proposed draft ToR by the proponent and make necessary additions/deletions to make it a comprehensive ToR that suits the statutory requirements for conducting the EIA studies.
- The concerned EAC/SEAC may constitute a sub-committee for a site visit if considered necessary. The sub-committee will act up on receiving a written approval from chairperson of the EAC/SEAC concerned. Project proponent will facilitate such site visits of the sub-committees.
 - EAC/SEAC shall provide an opportunity to the project proponent for presentation and discussions on the proposed project and related issues as well as the proposed ToR for EIA studies. If the State Government desires to present its views on any specific project in the scoping stage, it can depute an officer for the same at the scoping stage to EAC, as an invitee but not as a member of EAC. However, non-appearance of the project proponent before EAC/SEAC at any stage will not be a ground for rejection of the application for the prior environmental clearance.
 - If a new or expansion project is proposed in a problem area as identified by the CPCB, then the Ministry may invite a representative of SEIAA to the EAC to present their views, if any at the stage of scoping.
 - The final set of ToR for EIA Studies shall be conveyed to the proponent by the EAC/SEAC within sixty days of the receipt of Form 1 and pre-feasibility report. If the finalized ToR for EIA studies is not conveyed to the proponent within sixty days of the receipt of Form 1, the ToR suggested by the proponent shall be deemed as final and will be approved for EIA studies.
 - Final ToR for EIA Studies shall be displayed on the website of the MoEF/SEIAA.

- Applications for prior environmental clearance may be rejected by the concerned Authority based on the recommendations by the concerned EAC or SEAC at the scoping stage itself. In case of such rejection, the decision together with reasons for the same, shall be communicated to the proponent in writing within sixty days of the receipt of the application.
- The final EIA report and other relevant documents submitted by the applicant shall be scrutinized by the concerned Authority strictly with reference to the approved ToR for EIA studies.

4.3.1 Pre-feasibility report

As mentioned before, a pre-feasibility report along with completed Form 1 is to be submitted for obtaining prior environmental clearance and further processing. The pre-feasibility report will define the contours of the project and enable assessment of all relevant considerations. **Annexure VI** can be referred for preferable points in the pre-feasibility report.

4.3.2 Guidance for providing information in Form 1

The information given in specifically designed pre-feasibility report for this developmental activity may also be availed for filling Form 1.

Form 1 is designed to help users identify the likely significant environmental effects of proposed projects right at the scoping stage. There are two stages for providing information under two columns:

- First - identifying the relevant project activities from the list given in column 2 of Form 1. Start with the checklist of questions set out below and complete Column 3 by answering:
 - Yes - if the activity is likely to occur during implementation of the project
 - No - if it is not expected to occur
 - May be - if it is uncertain at this stage whether it will occur or not
- Second - Each activity for which the answer in Column 3 is “Yes” the next step is to refer to the fourth column which quantifies the volume of activity which could be judged as significant impact on the local environmental characteristics, and identify the areas that could be affected by that activity during construction /operation / decommissioning of the project. Form 1 requires information within 15 km around the project, whereas actual study area for EIA will be as prescribed by respective EAC/SEAC. Project proponent will need information about the surrounding VECs in order to complete this Form 1.

4.3.3 Identification of appropriate valued environmental components

VECs are components of natural resources and human world that are considered valuable and are likely to be affected by the project activities. Value may be attributed for economic, social, environmental, aesthetic or ethical reasons. VECs represent the investigative focal point for further EIA process. The indirect and/or cumulative effects can be concerned with indirect, additive or even synergistic effects due to other projects or activities or even induced developments on the same environmental components as would be considered direct effects. But such impacts tend to involve larger scale VECs such as within entire region, river basins or watersheds; and, broad social and economic

VECs such as quality of life and the provincial economy. Once VECs are identified, then appropriate indicators are selected for impact assessments on the respective VECs.

4.3.4 Methods for identification of impacts

There are various factors which influence the approach adopted for the assessment of direct, indirect, cumulative impacts, *etc.* for a particular project. The method should be practical and suitable for the project given the data, time and financial resources available. However, the method adopted should be able to provide a meaningful conclusion from which it would be possible to develop, where necessary, mitigation measures and monitoring. Key points to consider when choosing the method(s) include:

- Nature of the impact(s)
- Availability and quality of data
- Availability of resources (time, finance and staff)

The method chosen should not be complex, but should aim at presenting the results in a way that can be easily understood by the developer, decision maker and the public. A comparative analysis of major impact identification methods is given in Table 4-1.

Table 4-1: Advantages and Disadvantages of Impact Identification Methods

	Description	Advantages	Disadvantages
Checklists	<ul style="list-style-type: none"> ▪ Annotate the environmental features that need to be addressed when identifying the impacts of activities in the project 	<ul style="list-style-type: none"> ▪ Simple to understand and use ▪ Good for site selection and priority setting ▪ Simple ranking and weighting 	<ul style="list-style-type: none"> ▪ Do not distinguish between direct and indirect impacts ▪ Do not link action and impact ▪ The process of incorporating values can be controversial
Matrices	<ul style="list-style-type: none"> ▪ Identify the interaction between project activities (along one axis) and environmental characteristics (along other axis) using a grid like table ▪ Entries are made in the cells which highlights impact severity in the form of symbols or numbers or descriptive comments 	<ul style="list-style-type: none"> ▪ Link action to impact ▪ Good method for displaying EIA results 	<ul style="list-style-type: none"> ▪ Difficult to distinguish direct and indirect impacts ▪ Significant potential for double-counting of impacts
Networks	<ul style="list-style-type: none"> ▪ Illustrate cause effect relationship of project activities and environmental characteristics ▪ Useful in identifying secondary impacts ▪ Useful for establishing impact hypothesis and other structured science based approaches to EIA 	<ul style="list-style-type: none"> ▪ Links action to impact ▪ Useful in simplified form for checking for second order impacts ▪ Handles direct and indirect impacts 	<ul style="list-style-type: none"> ▪ Can become very complex if used beyond simplified version

	Description	Advantages	Disadvantages
Overlays	<ul style="list-style-type: none"> ▪ Map the impacts spatially and displays them pictorially ▪ Useful for comparing site and planning alternatives for routing linear developments ▪ Can address cumulative effects ▪ Information incentive 	<ul style="list-style-type: none"> ▪ Easy to understand ▪ Good to display method ▪ Good siting tool 	<ul style="list-style-type: none"> ▪ Addresses only direct impacts ▪ Does not address impact duration or probability
GIS	<ul style="list-style-type: none"> ▪ Maps the impacts spatially and display them pictorially ▪ Useful for comparing site and planning alternatives for routing linear developments ▪ Can address cumulative effects ▪ Information incentive 	<ul style="list-style-type: none"> ▪ Easy to understand ▪ Good to display method ▪ Good siting tool ▪ Excellent for impact identification and analysis 	<ul style="list-style-type: none"> ▪ Do not address impact duration or probability ▪ Heavy reliance on knowledge and data ▪ Often complex and expensive
Expert System	<ul style="list-style-type: none"> ▪ Assist diagnosis, problem solving and decision making ▪ collects inputs from user by answering systematically developed questions to identify impacts and determine their mitigability and significance ▪ Information intensive, high investment methods of analysis 	<ul style="list-style-type: none"> ▪ Excellent for impact identification and analysis ▪ Good for experimenting 	<ul style="list-style-type: none"> ▪ Heavy reliance on knowledge and data ▪ Often complex and expensive

The project team made an attempt to construct an impact matrix considering major project activities (generic operations) and stage-specific likely impacts which is given in Table 4-2.

While the impact matrix is project-specific, Table 4-2 may facilitate the stakeholders in identifying a set of components and phase-specific project activities for determination of likely impacts. Location-specific concerns may vary from case to case, therefore, the components even without likely impacts are also retained in the matrix for the location-specific reference.

Table 4-2: Matrix of Impacts

			PHASE I					PHASE II							PHASE III								
			Pre Construction					Construction/ Establishment							Operation and Maintenance								
1	2	3	4	5	6	7	8	9	10	11	12	13	14	15	16	17	18	19	20	21	22		
ENVIRONMENT	Component	Project Activities Parameter/ factor	Detailed Topographic Survey	Land Acquirement	Site Clearing	Burning of wastes, refuse and cleared vegetation	Site Preparation / Change in Topography	Civil works such as earth moving and building of structures including temporary structures	Heavy Equipment operations	Disposal of construction wastes	Generation of sewerage	Influx of construction workers	Deforestation	Transportation of material	Movement of Energy Reserves	Crushing of coal, storage and handling/ stock piling	Operation of power source and generator facilities	Abstraction of water	Operation of cooling systems	Storage of chemicals/ flammables	Waste management (fly ash, sludge from water treatment plants, cooling tower, boiler, ETP etc.		
Physical	Soil	Erosion Risks																					
		Contamination						*															
		Soil Quality							*														
	Resources	Fuels/ Electricity														*	*	*					
		Raw materials							*							*	*						
		Land especially undeveloped or agricultural land																					
	Water	Interpretation or Alteration of River Beds						*															
		Alteration of Hydraulic Regime																					
		Alteration of surface run-off and interflow						*	*														
		Alteration of aquifers						*	*														
		Water quality							*														
	Air	Temperature																	*				
		Air quality				*			*	*							*	*					
		Noise							*	*							*	*					
		Climate																					

Operational Aspects of an EIA

			PHASE I					PHASE II							PHASE III								
			Pre Construction					Construction/ Establishment							Operation and Maintenance								
1	2	3	4	5	6	7	8	9	10	11	12	13	14	15	16	17	18	19	20	21	22		
Biological	Terrestrial Flora	Effect on grass & flowers																					
		Effect on trees & shrubs																					
		Effect on farmland																					
		Endangered species																					
	Aquatic Biota	Habitat removal																					
		Contamination of habitats																					
		Reduction of aquatic biota																					
	Terrestrial Fauna	Fragmentation of terrestrial habitats																					
		Disturbance of habitats by noise or vibration																					
Reduction of Biodiversity																							
Social	Economy	Creation of new economic activities	*																				
		Commercial value of properties																					
		Conflict due to negotiation and/ compensation payments																					
		Generation of temporary and permanent jobs																					
		Effect on crops							*														
		Reduction of farmland productivity																					
		Income for the state and private sector																					
		Savings for consumers & private consumers																					
		Savings in foreign currency for the state																					
	Education	Training in new technologies	*																				
		Training in new skills to workers	*																				

Operational Aspects of an EIA

			PHASE I					PHASE II							PHASE III						
			Pre Construction					Construction/ Establishment							Operation and Maintenance						
1	2	3	4	5	6	7	8	9	10	11	12	13	14	15	16	17	18	19	20	21	22
	Public Order	Political Conflicts		*														*			
		Unrest, Demonstrations & Social conflicts		*															*		
	Infrastructure and Services	Conflicts with projects of urban, commercial or Industrial development	*					*													
	Security and Safety	Increase in Crime																			
		Accidents caused by															*			*	
	Health																				
	Cultural	Land use																			
		Recreation																			
		Aesthetics and human interest																			
		Cultural status																			

Note:

1. The above table represents a model for likely impacts, which will have to be arrived case-to-case basis considering VECs and significance analysis (Ref Section 2.9).

2. Project activities are shown as indicative. However, in Form 1 (application for EIA Clearance), for any question for which answer is 'Yes', then the corresponding activity shall reflect in project activities. Similarly 'parameters'/'factors' will also be changed within a component in order to reflect the target species of prime concern in the receiving local environment.

4.3.5 Testing the Significance of Impacts

The following set of conditions may be used as the checklist for testing the significance of the impacts and also to provide information in Column IV of Form 1.

- Will there be a large change in environmental conditions?
- Will new features be out-of-scale with the existing environment?
- Will the effect be unusual in the area or particularly complex?
- Will the effect extend over a large area?
- Will there be any potential for trans-frontier impact?
- Will many people be affected?
- Will many receptors of other types (fauna and flora, businesses, facilities) be affected?
- Will valuable or scarce features or resources be affected?
- Is there a risk that environmental standards will be breached?
- Is there a risk that protected sites, areas, and features will be affected?
- Is there a high probability of the effect occurring?
- Will the effect continue for a long time?
- Will the effect be permanent rather than temporary?
- Will the impact be continuous rather than intermittent?
- If it is intermittent will it be frequent rather than rare?
- Will the impact be irreversible?
- Will it be difficult to avoid, or reduce or repair or compensate for the effect?

For each “Yes” answer in column 3, the nature of effects and reasons for it should be recorded in the column 4. The questions are designed so that a “Yes” answer in column 3, will generally point towards the need for analyzing for the significance and requirement for conducting impact assessment for the effect.

4.3.6 Terms of reference for EIA studies

For the limestone mine captive to cement plants, separate ToRs specified for cement and as well as mining are required to be considered. In this manual, only the ToR for cement plants is detailed. ToR for EIA studies may include, but not limited to the following:

1. Executive summary of the project – giving a *prima facie* idea of the objectives of the proposal, use of resources, justification, *etc.* In addition, it should provide a compilation of EIA report, including EMP and the post-project monitoring plan in brief.

Project description

2. Justification for selecting the proposed unit size.
3. Land requirement for the project including its break up for various purposes, its availability and optimization..
4. Details of proposed layout clearly demarcating various units within the plant.
5. Complete process flow diagram describing each unit, its processes and operations, along with material and energy inputs & outputs (material and energy balance).
6. Details of proposed source-specific pollution control schemes and equipments to meet the national standards.

7. Details on requirement of raw materials, its source and storage at the plant.
8. Details on locating the residential colonies on upwind direction.
9. Details of the proposed methods of water conservation and recharging.
10. Management plan for solid/hazardous waste generation, storage, utilization and disposal.
11. In case, hazardous waste is proposed to be charged in kilns, details on type of waste, its characteristics and monitoring of emissions of gases, heavy metals, VOCs, dioxins and furans.
12. Scheme of proper storage of fly ash, gypsum, clinker.
13. Analysis report of Sulphur content in fuels and Sulphur balance data.
14. Details of heat and noise emission sources from the proposed project and proposed measures.
15. Details of CO₂ emissions including its quantum per tonne of cement.
16. Details regarding infrastructure facilities such as sanitation, fuel storage, restroom, etc. to the workers during construction and operation phase.
17. In case of expansion of existing industries, remediation measures adopted to restore the environmental quality if the groundwater, soil, crop, air, etc., are affected and a detailed compliance to the prior environmental clearance/consent conditions.
18. Any litigation pending against the project and /or any direction /order passed by any Court of Law related to the environmental pollution and impacts in the last two years, if so, details thereof.

Description of the environment

19. The study area shall be up to a distance of 10 km from the boundary of the proposed project site.
20. Location of the project site, mine, and nearest habitats with distances from the project site to be demarcated on a toposheet (1: 50000 scale).
21. Landuse based on satellite imagery including location specific sensitivities such as national parks / wildlife sanctuary, villages, industries, etc. for the study area.
22. Demography details of all the villages.
23. Topography details of the project area.
24. The baseline data to be collected from the study area w.r.t. different components of environment viz. air, noise, water, land, and biology and socio-economic (please refer Section 4.4.2 for guidance for assessment of baseline components and identify attributes of concern). Actual monitoring of baseline environmental components shall be strictly according to the parameters prescribed in the ToR after considering the proposed coverage of parameters by the proponent in draft ToR and shall commence after finalization of ToR by the competent Authority.
25. Details of geological features of the study area and mine area. Hydrological regime plan shall be prepared and incorporated. Interception of mining with the groundwater, if any.
26. Surface water quality of nearby water sources and other surface drains.
27. Details on ground water quality.

28. Details on existing ambient air quality and expected, stack and fugitive emissions for PM₁₀, PM 2.5, SO₂* and other sulphur compounds, NO_x* and other nitrogen compounds, carbon oxides (CO and CO₂) etc., and evaluation of the adequacy of the proposed pollution control devices to meet standards for point sources and to meet AAQ standards. (* - As applicable)
29. Details on other pollutants also to be considered in relation to the production of cement, especially with secondary fuels are VOC, polychlorinated dibenzodioxins and dibenzofurans (PCDDs and PCDFs), metals and their compounds, Hydrogen Fluoride, Hydrochloric Acid (HCl), etc.
30. The air quality contours may be plotted on a location map showing the location of project site, habitation nearby, sensitive receptors, if any and wind roses.
31. Chemical characterization of RSPM data.
32. Details on baseline data on silicosis in buffer and core zone.
33. Details on noise levels at sensitive/commercial receptors.
34. Site-specific micro-meteorological data including mixing height.
35. One season site-specific data excluding monsoon season.
36. Proposed baseline monitoring network for the consideration and approval of the Competent Authority.
37. Ecological status (terrestrial and aquatic) of the study area such as habitat type and quality, species, diversity, rarity, fragmentation, ecological linkage, age, abundance, etc.
38. If any incompatible land use attributes fall within project area, proponent shall describe the sensitivity (distance, area and significance) and propose the additional points based on significance for review and acceptance by the EAC/SEAC. Incompatible land use attributes include:
 - Public water supply areas from rivers/surface water bodies, from ground water
 - Scenic areas/tourism areas/hill resorts
 - Religious places, pilgrim centers that attract over 10 lakh pilgrims a year
 - Protected tribal settlements (notified tribal areas where industrial activity is not permitted)
 - Monuments of national significance, World Heritage Sites
 - Cyclone, Tsunami prone areas (based on last 25 years);
 - Airport areas
 - Any other feature as specified by the State or local government and other features as locally applicable, including prime agricultural lands, pastures, migratory corridors, etc.
39. If ecologically sensitive attributes fall within the project area, proponent shall describe the sensitivity (distance, area and significance) and propose the additional points based on significance for review and acceptance by the EAC/ SEAC. Ecological sensitive attributes include:
 - National parks
 - Wild life sanctuaries Game reserve
 - Tiger reserve/elephant reserve/turtle nesting ground
 - Mangrove area
 - Wetlands
 - Reserved and Protected forests, etc.

- Any other closed/protected area under the Wild Life (Protection) Act, 1972, any other area locally applicable
- 40. If the location falls in Valley, specific issues connected to the natural resources management shall be studied and presented.
- 41. If the location falls in CRZ area: A CRZ map duly authenticated by one of the authorized agencies demarcating LTL, HTL, CRZ area, location of the project and associate facilities w.r.t. CRZ, coastal features such as mangroves, if any. The route of the pipeline, conveyor system *etc.*, passing through CRZ, if any, should also be demarcated. Recommendations of the State Coastal Management Authority for the activities to be taken up in the CRZ.
 - Provide the CRZ map in 1:10000 scale in general cases and in 1:5000 scale for specific observations.
 - Proposed site for disposal of dredged material and environmental quality at the point of disposal/impact areas.
 - Fisheries study should be done w.r.t. Benthos and Marine organic material and coastal fisheries.

Anticipated environmental impacts and mitigation measures

- 42. Anticipated generic environmental impacts due to this project are indicated in Table 4-2, which may be evaluated for significance and based on corresponding likely impacts VECs may be identified. Baseline studies may be conducted for all the concerned VECs and likely impacts will have to be assessed for their magnitude in order to identify mitigation measures (please refer Chapter 4 of the manual for guidance).
- 43. Tools as given in Section 4.4.3 may be referred for the appropriate assessment of environmental impacts and same may be submitted in draft ToR for consideration and approval by EAC/SEAC.
- 44. While identifying the likely impacts, also include the following for analysis of significance and required mitigation measures:
 - impacts due to transportation of raw materials and end products on the surrounding environment
 - impacts on surface water, soil and groundwater
 - impacts due to air pollution
 - impacts due to odour pollution
 - impacts due to noise
 - impacts due to fugitive emissions
 - impact on health of workers due to proposed project activities
- 45. Proposed odour control measures.
- 46. Action plan for the greenbelt development – species, width of plantations, planning schedule etc. in accordance to CPCB published guidelines.
- 47. In case of likely impact from the proposed project on the surrounding reserve forests, Plan for the conservation of wild fauna in consultation with the State Forest Department.
- 48. For identifying the mitigation measures, please refer Chapter III for source control and treatment. Besides typical mitigation measures which may also be considered are discussed in Table 4-5.

49. Air quality modeling for the cement plant should be incorporated. Air pollution control system to be installed should be elaborated upon to control emissions within 50 mg/Nm³.
50. Details on rainwater harvesting at the cement plant site.

Analysis of alternative resources and technologies

51. Comparison of alternate sites considered and the reasons for selecting the proposed site. Conformity of the site with the prescribed guidelines in terms of CRZ, river, highways, railways, *etc.*
52. Details of improved technologies.

Environmental monitoring program

53. Specific programme to monitor Nickel and Vanadium emissions be included, in case of use of pet-coke.
54. An action plan to control and monitor secondary fugitive emissions as per the CPCB guidelines.
55. Monitoring programme for pollution control at source.
56. Monitoring pollutants at receiving environment for the appropriate notified parameters – air quality, groundwater, surface water, *etc.* during operational phase of the project.
57. Specific programme to monitor safety and health protection of workers.
58. Appropriate monitoring network has to be designed and proposed, to assess the possible residual impacts on VECs.
59. Details of in-house monitoring capabilities and the recognized agencies if proposed for conducting monitoring.

Additional studies

60. Clearances/approvals from the IBM and State government for the linked mining component.
61. Details on risk assessment and damage control during different phases of the project and proposed safeguard measures.
62. Details on socio-economic development activities such as commercial property values, generation of jobs, education, social conflicts, cultural status, accidents, *etc.*
63. Proposed plan to handle the socio-economic influence on the local community. The plan should include quantitative dimension as far as possible.
64. Details on compensation package for the people affected by the project, considering the socio-economic status of the area, homestead oustees, land oustees, and landless labourers.
65. Points identified in the public hearing and commitment of the project proponent to the same. Detailed action plan addressing the issues raised, and the details of necessary allocation of funds.

Environmental management plan

- 66. Administrative and technical organizational structure to ensure proposed post-project monitoring programme for approved mitigation measures..
- 67. EMP devised to mitigate the adverse impacts of the project should be provided along with item-wise cost of its implementation (Capital and recurring costs).
- 68. Allocation of resources and responsibilities for plan implementation.
- 69. Details of the emergency preparedness plan and on-site and off-site disaster management plan.

Note:

Above points shall be adequately addressed in the EIA report at corresponding chapters, in addition to the contents given in the reporting structure (Table 4-6).

4.4 Environmental Impact Assessment

The generic approach for accomplishing EIA studies is shown in Figure 4.-3. Each stage is discussed in detail, in subsequent sections.

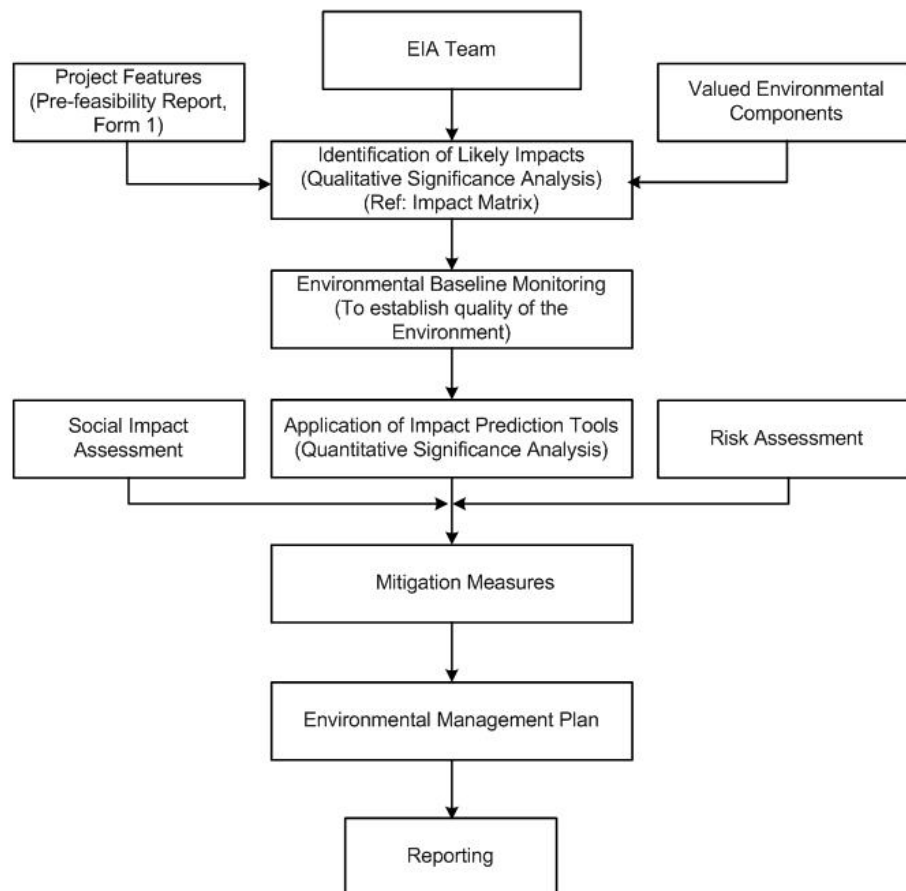

Figure 4-3: Approach for EIA Study

4.4.1 EIA team

The success of a multi-functional activity like an EIA primarily depends on constitution of a right team at the right time (preferable at the initial stages of an EIA) in order to assess the significant impacts (direct, indirect as well as cumulative impacts).

The professional Team identified for a specific EIA study should comprise of qualified and experienced professionals from various disciplines in order to address the critical aspects identified for the specific project. Based on the nature and the environmental setting, following professionals may be identified for EIA studies:

- Environmental management specialist/Regulator
- Cement technologist
- Air and noise quality
- Occupational health
- Geology/geo-hydrology
- Ecologist
- Transportation Specialist
- Safety and health specialist
- Social scientist, *etc.*

4.4.2 Baseline quality of the environment

EIA Notification 2006 specifies that an EIA Report should contain a description of the existing environment that would be or might be affected directly or indirectly by the proposed project. Environmental Baseline Monitoring (EBM) is a very important stage of EIA. On one hand EBM plays a very vital role in EIA and on the other hand it provides feedback about the actual environmental impacts of a project. EBM, during the operational phase, helps in judging the success of mitigation measures in protecting the environment. Mitigation measures, in turn are used to ensure compliance with environmental standards, and to facilitate the needed project design or operational changes.

Description of the existing environment should include natural, cultural, socio-economic systems and their interrelationships. The intention is not to describe all baseline conditions, but to focus the collection and description of baseline data on those VECs that are important and are likely to be affected by the proposed industrial activity.

4.4.2.1 Objective of EBM in EIA context

The term 'baseline' refers to conditions existing before development. EBM studies are carried out to:

- identify environmental conditions which might influence project design decisions (e.g., site layout, structural or operational characteristics);
- identify sensitive issues or areas requiring mitigation or compensation;
- provide input data to analytical models used for predicting effects;
- provide baseline data against which the results of future monitoring programs can be compared.

At this stage of EIA process, EBM is primarily discussed in the context of first purpose wherein feedback from EBM programs may be used to:

- determine available assimilative capacity of different environmental components within the designated impact zone and whether more or less stringent mitigation measures are needed; and
- improve predictive capability of EIAs

There are many institutional, scientific, quality control, and fiscal issues that must be addressed in implementation of an environmental monitoring program. Careful consideration of these issues in the design and planning stages will help avoid many of the pitfalls associated with environmental monitoring programs.

4.4.2.2 Environmental monitoring network design

Monitoring refers to the collection of data through a series of repetitive measurements of environmental parameters (or, more generally, to a process of systematic observation). Design of the environmental quality monitoring programme depends up on the monitoring objectives specified for the selected area of interest. Types of monitoring and network design considerations are discussed in **Annexure VII**.

4.4.2.3 Baseline data generation

List of important physical environmental components and indicators of EBM are given in Table 4-3.

Table 4-3: List of Important Physical Environment Components and Indicators of EBM

Environmental Component	Environmental Indicators
Climatic variables	<ul style="list-style-type: none"> ▪ Rainfall patterns – mean, mode, seasonality ▪ Temperature patterns ▪ Extreme events ▪ Climate change projections ▪ Prevailing wind - direction, speed, anomalies ▪ Relative humidity ▪ Stability conditions and mixing height, <i>etc.</i>
Geology	<ul style="list-style-type: none"> ▪ Underlying rock type, texture ▪ Surgical material ▪ Geologic structures (faults, shear zones, <i>etc.</i>) ▪ Geologic resources (minerals, <i>etc.</i>)
Topography	<ul style="list-style-type: none"> ▪ Slope form ▪ Landform and terrain analysis ▪ Specific landform types, <i>etc.</i>
Coastal dynamics and morphology	<ul style="list-style-type: none"> ▪ Wave patterns ▪ Currents ▪ Shoreline morphology – near shore, foreshore ▪ Sediment – characteristics and transport, <i>etc.</i>
Soil	<ul style="list-style-type: none"> ▪ Type and characteristics ▪ Porosity and permeability ▪ Sub-soil permeability ▪ Run-off rate ▪ Infiltration capacity ▪ Effective depth (inches/centimeters) ▪ Inherent fertility, <i>etc.</i>

Environmental Component	Environmental Indicators
	<ul style="list-style-type: none"> ▪ Suitability for method of sewage disposal, <i>etc.</i>
Drainage	<ul style="list-style-type: none"> ▪ Surface hydrology ▪ Natural drainage pattern and network ▪ Rainfall runoff relationships ▪ Hydrogeology ▪ Groundwater characteristics – springs, <i>etc.</i>
Water	<ul style="list-style-type: none"> ▪ Raw water availability ▪ Water quality ▪ Surface water (Terrestrial - rivers, lakes, ponds, gullies) – quality, water depths, flooding areas, <i>etc.</i> ▪ Ground water – water table, local aquifer storage capacity, specific yeild, specific retention, water level depths and fluctuations, <i>etc.</i> ▪ Coastal ▪ Floodplains ▪ Wastewater discharges ▪ Thermal discharges ▪ Waste discharges, <i>etc.</i>
Air	<ul style="list-style-type: none"> ▪ Ambient ▪ Respirable ▪ Airshed importance ▪ Odour levels, <i>etc.</i>
Noise	<ul style="list-style-type: none"> ▪ Identifying sources of noise ▪ Noise due to traffic/transportation of vehicles ▪ Noise due to heavy equipment operations ▪ Duration and variations in noise over time, <i>etc.</i>
Biological	<ul style="list-style-type: none"> ▪ Species composition of flora and fauna ▪ Flora – type, density, exploitation, <i>etc.</i> ▪ Fauna – distribution, abundance, rarity, migratory, species diversity, habitat requirements, habitat resilience, economic significance, comemrcial value, <i>etc.</i> ▪ Fisheries – migratory species, species with commercial/recreational value, <i>etc.</i>
Landuse	<ul style="list-style-type: none"> ▪ Landuse pattern, <i>etc.</i>

Guidance for assessment of baseline components and attributes describing sampling network, sampling frequency, method of measurement is given in **Annexure VIII**.

Infrastructure requirements for EBM

In addition to devising a monitoring network design and monitoring plan/program, it is also necessary to ensure adequate resources in terms of staffing, skills, equipment, training, budget, *etc.*, for its implementation. Besides assigning institutional responsibility, reporting requirements, QA/QC plans and its enforcement capability are essential. A monitoring program that does not have an infrastructural support and QA/QC component will have little chance of success.

Defining data statistics/analyses requirements

The data analyses to be conducted are dictated by the objectives of environmental monitoring program. The statistical methods used to analyze data should be described in

detail prior to data collection. This is important because repetitive observations are recorded in time and space. Besides, the statistical methods could also be chosen so that uncertainty or error estimates in the data can be quantified. For *e.g.*, statistical methods useful in an environmental monitoring program include: 1) frequency distribution analysis; 2) analysis of variance; 3) analysis of covariance; 4) cluster analysis; 5) multiple regression analysis; 6) time series analysis; 7) the application of statistical models.

Use of secondary data

The EBM program for EIA can at best address temporal and/or spatial variations limited to a limited extent because of cost implications and time limitations. Therefore analysis of all available information or data is essential to establish the regional profiles. So all the relevant secondary data available for different environmental components should be collated and analyzed.

To facilitate stakeholders, IL&FS Ecosmart Ltd., has made an attempt to compile the list of information required for EIA studies and sources of secondary data, which are given in **Annexure IXA** and **Annexure IXB**.

4.4.3 Impact prediction tools

The scientific and technical credibility of an EIA relies on the ability of EIA practitioners to estimate the nature, extent, and magnitude of change in environmental components that may result from project activities. Information about predicted changes is needed for assigning impact significance, prescribing mitigation measures, and designing & developing EMPs and monitoring programs. The more accurate the predictions, the more confident the EIA practitioner will be in prescribing specific measures to eliminate or minimize the adverse impacts of development project.

Choice of models/methods for impact predictions in respect to air, noise, land, biological and socio-economic environment are precisely tabulated in **Annexure X**.

4.4.4 Significance of the impacts

Evaluating the significance of environmental effects is perhaps the most critical component of impact analysis. The interpretation of significance bears directly on the subsequent EIA process and also during environmental clearance on project approvals and condition setting. At an early stage, it also enters into screening and scoping decisions on what level of assessment is required and which impacts and issues will be addressed.

Impact significance is also a key to choosing among alternatives. In total, the attribution of significance continues throughout the EIA process, from scoping to EIS review, in a gradually narrowing “cone of resolution” in which one stage sets up the next. But at this stage it is the most important as better understanding and quantification of impact significance is required.

One common approach is based on determination of the significance of predicted changes in the baseline environmental characteristics and compares these w.r.t regulatory standards, objective criteria and similar ‘thresholds’ as eco-sensitivity, cultural /religious values. Often, these are outlined in guidance. A better test proposed by the CEAA (1995) is to determine if ‘residual’ environmental effects are adverse, significant, and

likely (given under). But at this stage, the practice of formally evaluating significance of residual impacts, i.e., after predicting the nature and magnitude of impacts based on before-versus-after-project comparisons, and identifying measures to mitigate these effects is not being followed in a systematic way.

i Step 1: Are the environmental effects adverse?

Criteria for determining if effects are “adverse” include:

- effects on biota health
- effects on rare or endangered species
- reductions in species diversity
- habitat loss
- transformation of natural landscapes
- effects on human health
- effects on current use of lands and resources for traditional purposes by aboriginal persons; and
- foreclosure of future resource use or production

ii Step 2: Are the adverse environmental effects significant?

Criteria for determining ‘significance’ are to judge that the impacts:

- are extensive over space or time
- are intensive in concentration or proportion to assimilative capacity
- exceed environmental standards or thresholds
- do not comply with environmental policies, landuse plans, sustainability strategy
- adversely and seriously affect ecologically sensitive areas
- adversely and seriously affect heritage resources, other landuses, community lifestyle and/or indigenous peoples traditions and values

iii Step 3: Are the significant adverse environmental effects likely?

Criteria for determining ‘likelihood’ include:

- probability of occurrence, and
- scientific uncertainty

4.5 Social Impact Assessment

Social Impact Assessment (SIA) is an instrument used to analyze social issues and solicit stakeholder views for the design of projects. SIA helps in making the project responsive to social development concerns, including options that enhance benefits for poor and vulnerable people while mitigating risk and adverse impacts. It analyzes distributional impacts of intended project benefits on different stakeholder groups, and identifies differences in assets and capabilities to access the project benefits.

The scope and depth of SIA should be determined by the complexity and importance of issues studied, taking into account the skills and resources available. SIA should include studies related to involuntary resettlement, compulsory land acquisition, impact of imported workforces, job losses among local people, damage to sites of cultural, historic

or scientific interest, impact on minority or vulnerable groups, child or bonded labour, use of armed security guards. However, SIA may primarily include the following:

Description of the socio-economic, cultural and institutional profile

Conduct a rapid review of available sources of information to describe the socio-economic, cultural and institutional interface in which the project operates.

Socio-economic and cultural profile: Describe the most significant social, economic and cultural features that differentiate social groups in the project area. Describe different interests in the project, and their levels of influence. Explain any specific effects that the project may have on the poor and underprivileged. Identify any known conflicts among groups that may affect project implementation.

Institutional profile: Describe the institutional environment; consider both the presence and function of public, private and civil society institutions relevant to the operation. Are there important constraints within existing institutions *e.g.*, disconnect between institutional responsibilities and the interests and behaviors of personnel within those institutions? Or are there opportunities to utilize the potential of existing institutions, *e.g.*, private or civil society institutions, to strengthen implementation capacity.

Legislative and regulatory considerations

To review laws and regulations governing the project's implementation and access of poor and excluded groups to goods, services and opportunities provided by the project. In addition, review the enabling environment for public participation and development planning. SIA should build on strong aspects of legal and regulatory systems to facilitate program implementation and identify weak aspects while recommending alternative arrangements.

Key social issues

SIA provides baseline information for designing social development strategy. The analysis should determine the key social and Institutional issues which affect the project objectives; identify the key stakeholder groups in this context and determine how relationships between stakeholder groups will affect or be affected by the project; and identify expected social development outcomes and actions proposed to achieve those outcomes

Data collection and methodology

Describe the design and methodology for social analysis. In this regard:

- Build on existing data
- Clarify the units of analysis for social assessment: intra-household, household level, as well as communities/settlements and other relevant social aggregations on which data is available or will be collected for analysis
- Choose appropriate data collection and analytical tools and methods, employing mixed methods wherever possible; mixed methods include a mix of quantitative and qualitative methods

Strategy to achieve social development outcomes

Identify the likely social development outcomes of the project and propose a social development strategy, including recommendations for institutional arrangements to achieve them, based on the findings of the social assessment. The social development strategy could include measures that:

- strengthen social inclusion by ensuring inclusion of both poor and excluded groups and intended beneficiaries are included in the benefit stream; offer access to opportunities created by the project
- empower stakeholders through their participation in design and implementation of the project, their access to information, and their increased voice and accountability (*i.e.*, a participation framework); and
- enhance security by minimizing and managing likely social risks and increasing the resilience of intended beneficiaries and affected persons to socioeconomic shocks

Implications for analysis of alternatives

Review proposed approaches for the project, and compare them in terms of their relative impacts and social development outcomes. Consider what implications the findings of social assessment might have on those approaches. Should some new components be added to the approach, or other components be reconsidered or modified?

If SIA and consultation processes indicate that alternative approaches may have better development outcomes, such alternatives should be described and considered, along with the likely budgetary and administrative effects these changes might have.

Recommendations for project design and implementation arrangements

Provide guidance to project management and other stakeholders on how to integrate social development issues into project design and implementation arrangements. As much as possible, suggest specific action plans or implementation mechanisms to address relevant social issues and potential impacts. These can be developed as integrated or separate action plans, for example, as Resettlement Action Plans, Indigenous Peoples Development Plans, Community Development Plans, *etc.*

Developing a monitoring plan

Through SIA process, a framework for monitoring and evaluation should be developed. To the extent possible, this should be done in consultation with key stakeholders, especially beneficiaries and affected people.

The framework shall identify expected social development indicators, establish benchmarks, and design systems and mechanisms for measuring progress and results related to social development objectives. The framework shall identify organizational responsibilities in terms of monitoring, supervision, and evaluation procedures. Wherever possible, participatory monitoring mechanisms shall be incorporated. The framework should establish:

- a set of monitoring indicators to track the progress achieved. The benchmarks and indicators should be limited in number, and should combine both quantitative and qualitative types of data. The indicators for outputs to be achieved by the social

development strategy should include indicators to monitor the process of stakeholder participation, implementation and institutional reform

- indicators to monitor social risk and social development outcomes; and indicators to monitor impacts of the project's social development strategy. It is important to suggest mechanisms through which lessons learnt from monitoring and stakeholder feedback can result in changes to improve the operation of the project. Indicators should be of such nature that results and impacts can be disaggregated by gender and other relevant social groups
- define transparent evaluation procedures. Depending on context, these may include a combination of methods, such as participant observation, key informant interviews, focus group discussions, census and socio-economic surveys, gender analysis, Participatory Rural Appraisal (PRA), Participatory Poverty Assessment (PPA) methodologies, and other tools. Such procedures should be tailored to the special conditions of the project and to the different groups living in the project area; Estimate resource and budget requirements for monitoring and evaluation activities, and a description of other inputs (such as institutional strengthening and capacity building) needs to be carried out.

4.6 Risk Assessment

Industrial accidents results in great personal and financial loss. Managing these accidental risks in today's environment is the concern of every industry including cement plants, because either real or perceived incidents can quickly jeopardize the financial viability of a business. Many facilities involve various manufacturing processes that have the potential for accidents which may be catastrophic to the plant, work force, environment, or public.

The main objective of risk assessment study is to propose a comprehensive but simple approach to carry out risk analysis and conducting feasibility studies for industries, planning and management of industrial prototype hazard analysis study in Indian context.

Risk analysis and risk assessment should provide details on Quantitative Risk Assessment (QRA) techniques used world-over to determine risk posed to people who work inside or live near hazardous facilities, and to aid in preparing effective emergency response plans by delineating a Disaster Management Plan (DMP) to handle onsite and offsite emergencies. Hence, QRA is an invaluable method for making informed risk-based process safety and environmental impact planning decisions, as well as being fundamental to any decision while siting a facility. QRA whether, site-specific or risk-specific for any plant is complex and needs extensive study that involves process understanding, hazard identification, consequence modeling, probability data, vulnerability models/data, local weather and terrain conditions and local population data. QRA may be carried out to serve the following objectives:

- Identification of safety areas
- Identification of hazard sources
- Generation of accidental release scenarios for escape of hazardous materials from the facility
- Identification of vulnerable units with recourse to hazard indices
- Estimation of damage distances for the accidental release scenarios with recourse to Maximum Credible Accident (MCA) analysis
- Hazard and Operability studies (HAZOP) in order to identify potential failure cases of significant consequences

- Estimation of probability of occurrences of hazardous event through fault tree analysis and computation of reliability of various control paths
- Assessment of risk on basis of above evaluation against the risk acceptability criteria relevant to the situation
- Suggest risk mitigation measures based on engineering judgement, reliability and risk analysis approaches
- Delineation / upgradation of DMP
- Safety Reports: with external safety report/ occupational safety report

The risk assessment report may cover the following in terms of the extent of damage with resource to MCA analysis and delineation of risk mitigations measures with an approach to DMP.

- Hazard identification – identification of hazardous activities, hazardous materials, past accident records, *etc.*
- Hazard quantification – consequence analysis to assess the impacts
- Risk Presentation
- Risk Mitigation Measures
- Disaster Management Plans



Figure 4-4: Risk Assessment – Conceptual Framework

Methods of risk prediction should cover all the design intentions and operating parameters to quantify risk in terms of probability of occurrence of hazardous events and magnitude of its consequence. Table 4-4 shows the predictive models for risk assessment.

Table 4-4: Choice of Models for Impact Predictions: Risk Assessment

Name	Application	Remarks
EFFECT	Consequence Analysis for Visualization of accidental chemical release scenarios & its consequence	Heat load, press wave & toxic release exposure neutral gas dispersion
WHAZAN	Consequence Analysis for Visualization of accidental chemical release scenarios & its consequence	
EGADIS	Consequence Analysis for Visualization of accidental chemical release scenarios & its consequence	Dense gas dispersion

Operational Aspects of EIA

Name	Application	Remarks
HAZOP and Fault Tree Assessment	For estimating top event probability	Failure frequency data is required
Pathways reliability and protective system hazard analysis	For estimating reliability of equipments and protective systems	Markov models
Vulnerability Exposure models	Estimation of population exposure	Uses probit equation for population exposure
F-X and F-N curves	Individual / Societal risks	Graphical Representation

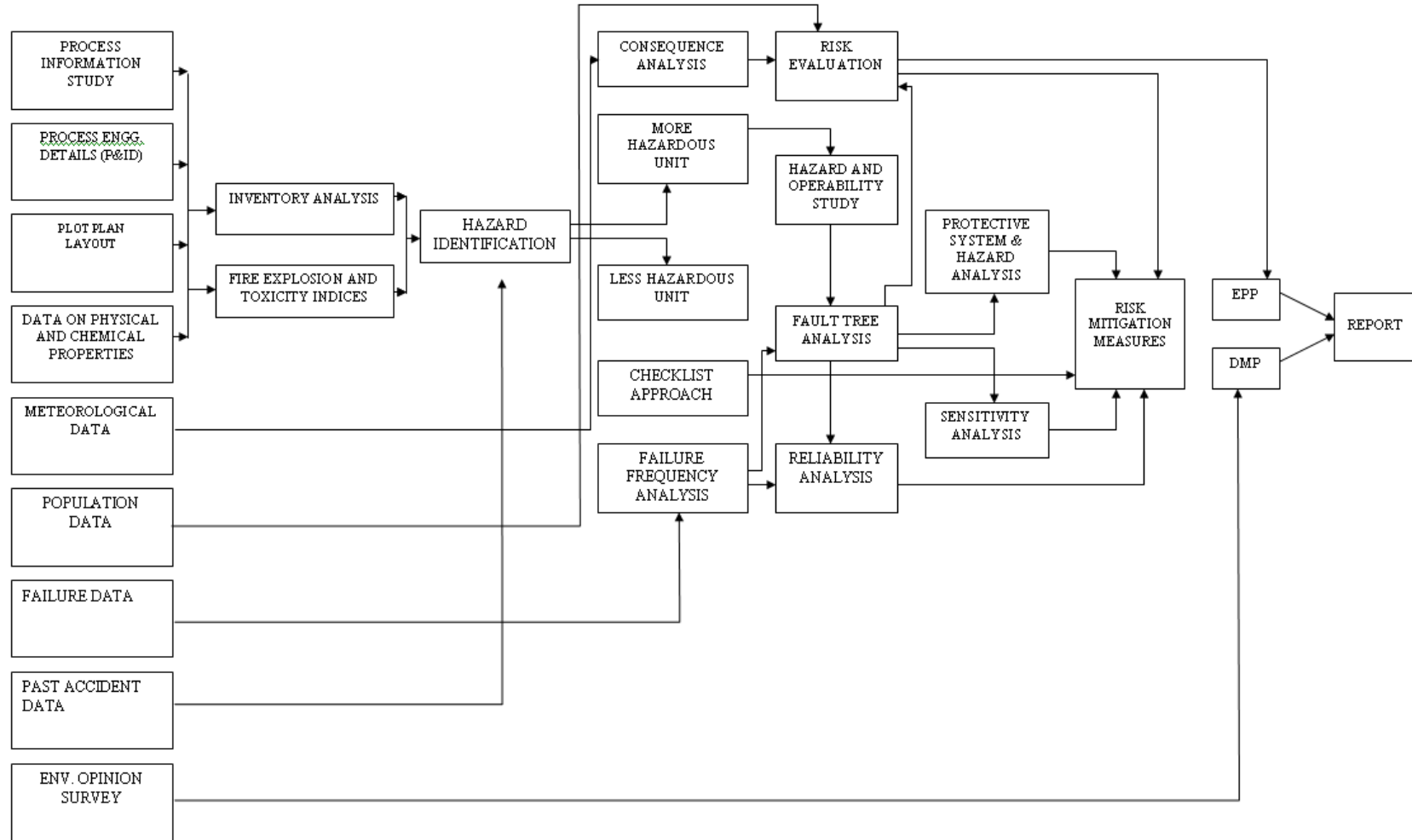

Figure 4-5: Comprehensive Risk Assessment - At a Glance

4.7 Mitigation Measures

The purpose of mitigation is to identify measures that safeguard the environment and the community affected by the proposal. Mitigation is both a creative and practical phase of the EIA process. It seeks to find the best ways and means of avoiding, minimizing and remedying impacts. Mitigation measures must be translated into action in right way and at the right time, if they are to be successful. This process is referred to as impact management and takes place during project implementation. A written plan should be prepared for this purpose, and should include a schedule of agreed actions. Opportunities for impact mitigation will occur throughout the project cycle.

4.7.1 Important considerations for mitigation methods

The responsibility of project proponents to ‘internalize’ the full environmental costs of development proposals is now widely accepted under “Polluter Pay” principle. In addition, many proponents have found that good design and impact management can result in significant savings applying the principles of cleaner production to improve their environmental performance.

- The predicted adverse environmental as well as social impacts, for which mitigation measures are required, should be identified and briefly summarized along with cross referencing them to the significance, prediction components of the EIA report or other documentation.
- Each mitigation measure should be briefly described w.r.t the impact of significances to which it relates and the conditions under which it is required (for example, continuously or in the event of contingencies). These should also be cross-referenced to the project design and operating procedures which elaborate on the technical aspects of implementing the various measures.
- Cost and responsibilities for mitigation and monitoring should be clearly defined, including arrangements for coordination among various Authorities responsible for mitigation.
- The proponent can use the EMP to develop environmental performance standards and requirements for the project site as well as supply chain. An EMP can be implemented through EMS for the operational phase of the project.

Prior to selecting mitigation plans it is appropriate to study the mitigation alternatives for cost-effectiveness, technical and socio-political feasibility. Such mitigation measures could include:

- avoiding sensitive areas such as eco-sensitive area, *e.g.*, fish spawning areas, dense mangrove areas or areas known to contain rare or endangered species
- adjusting work schedules to minimize disturbance
- engineered structures such as berms and noise attenuation barriers
- pollution control devices such as scrubbers and electrostatic precipitators, *etc.*,
- changes in fuel feed, manufacturing, process, technology use, or waste management practices, *etc.*

Other generic measures

- Extend education facility and vocational training to the children of the neighbouring villages.
- Extend hospital facilities for adjacent villages and provide community with water supply.
- Develop community projects to improve rural economy, health and sanitation standards, animal husbandry, *etc.*
- Conduct mass awareness programmes for villagers, township residents and employees about the chemicals / raw materials being used in the plant, emergency preparedness of the industry, *etc.*
- Develop green belt / greenery in and around the plant.
- Develop infrastructure like roads, power supply, transport, *etc.*
- Adopt rainwater harvesting to recharge the ground water.
- Adopt accredited Environment Management Systems: ISO 14001, OHSAS – 18001, *etc.*

4.7.2 Hierarchy of elements of mitigation plan

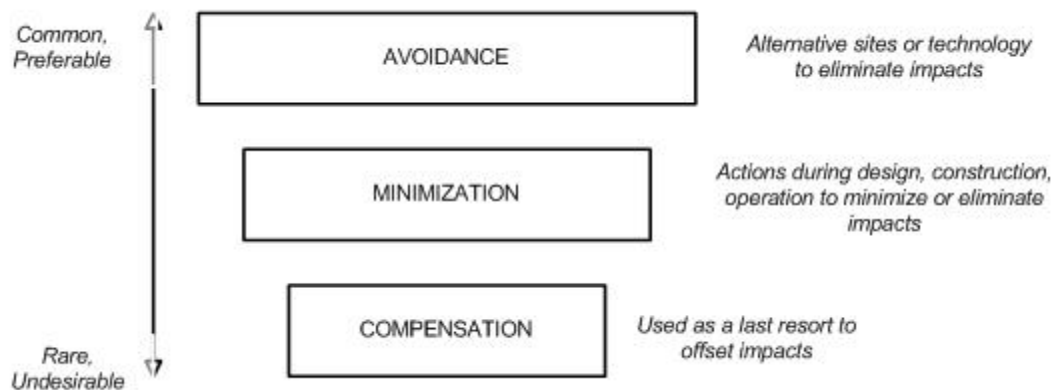

Figure 4-6: Elements of Mitigation

A good EIA practice requires technical understanding of relevant issues and the measures that work in such given circumstances. The priority of selection of mitigation measures should be in the order:

Step One: Impact avoidance

This step is most effective when applied at an early stage of project planning. It can be achieved by:

- not undertaking certain projects or elements that could result in adverse impacts
- avoiding areas that are environmentally sensitive
- putting in place the preventative measures to stop adverse impacts from occurring, for example, release of water from a reservoir to maintain a fisheries regime

Step Two: Impact minimization

This step is usually taken during impact identification and prediction to limit or reduce the degree, extent, magnitude, or duration of adverse impacts. It can be achieved by:

- scaling down or relocating the proposal
- redesigning elements of the project
- taking supplementary measures to manage the impacts

Step Three: Impact compensation

This step is usually applied to remedy unavoidable residual adverse impacts. It can be achieved by:

- rehabilitation of the affected site or environment, for example, by habitat enhancement and restocking fish
- restoration of the affected site or environment to its previous state or better, as typically required for mine sites, forestry roads and seismic lines
- replacement of the same resource values at another location. For example, by wetland engineering to provide an equivalent area to that lost to drainage or infill

Important compensation elements

Resettlement Plans: Special considerations apply to mitigation of proposals that displace or disrupt people. Certain types of projects, such as reservoirs and irrigation schemes and public works, are known to cause involuntary resettlement. This is a contentious issue because it involves far more than re-housing people; in addition, income sources and access to common property resources are likely to be lost. Almost certainly, a resettlement plan will be required to ensure that no one is worse off than before, which may not be possible for indigenous people whose culture and lifestyle is tied to a locality. This plan must include the means for those displaced to reconstruct their economies and communities and should include an EIA of the receiving areas. Particular attention should be given to indigenous, minority and vulnerable groups who are at higher risk from resettlement.

In-kind compensation

When significant or net residual loss or damage to the environment is likely, in kind compensation is appropriate. As noted earlier, environmental rehabilitation, restoration or replacement have become standard practices for many proponents. Now, increasing emphasis is given to a broader range of compensation measures to offset impacts and assure the sustainability of development proposals. These include impact compensation ‘trading’, such as offsetting CO₂ emissions by planting forests to sequester carbon.

4.7.3 Typical mitigation measures

Choice of location for the developmental activity plays an important role in preventing adverse impacts on surrounding environment. Detailed guidelines on siting of industries are provided in Section 4.2. However, if the developmental activity still produces any adverse impacts, mitigation measures should be taken.

Previous subsections of the Section 4.7 could be precisely summarized into following:

- Impacts from a developmental project could have many dimensions. As most of the direct impacts are caused by releases from developmental projects, often impact control at source is the best opportunity to either eliminate or mitigate impacts, in case these are cost-effective. In other words, the best way to mitigate the impacts is to prevent them from occurring. Choice of raw materials/technologies/processes which produce least impact would be one of the options to achieve it.
- After exploring cost-effective feasible alternatives to control impacts at source, various interventions to minimize the adverse impacts may be considered. These interventions, primarily aim at reducing the residual impacts on VECs of the receiving environment to the acceptable concentrations.
- Degree of control at source and external interventions differs from situation-to-situation and is largely governed by techno-economic feasibility. While the regulatory bodies stress for further source control (due to high reliability), the project proponents bargain for other interventions which may be relatively cost-effective than further control at source (in any case project authority is required to meet the industry-specific standards by adopting the best practicable technologies. However, if the location demands further control at source, then the proponents are required to adopt further advanced control technologies, *i.e.*, towards best available control technologies). After having discussions with the project proponent, EAC/SEAC reaches to an agreed level of source control + other interventions (together called as mitigation measures in the given context) that achieve the targeted protection levels for the VECs in the receiving environment. These levels will become the principle clearance conditions.
- Chapter 3 of this TGM offers elaborate information on cleaner technologies, waste minimization opportunities, and control technologies for various kinds of polluting parameters that emanate from this developmental activity (put sector name). This information may be used to draw appropriate control measures applicable at source.

The choice of interventions for mitigation of impacts may also be numerous and depend on various factors. Mitigation measures based on location-specific suitability and some other factors are discussed in sub-sections 4.7.1 and 4.7.2. A few typical measures which may also be explored for mitigation of impacts are listed in Table 4-5.

Table 4-5: Typical Mitigation Measures

Impacts	Typical Mitigation Measures
Soil	<ul style="list-style-type: none"> ▪ Windscreens, maintenance, and installation of ground cover ▪ Installation of drainage ditches ▪ Runoff and retention ponds ▪ Minimize disturbances and scarification of the surface ▪ Usage of appropriate monitoring and control facilities for construction equipments deployed ▪ Methods to reuse earth material generated during excavation
Resources – fuel/construction material, etc.	<ul style="list-style-type: none"> ▪ Availing the resources which could be replenished by natural systems, etc.
Deforestation	<ul style="list-style-type: none"> ▪ Plant or create similar areas ▪ Initiate a tree planting program in other areas ▪ Donate land to conservationist groups
Water pollution (Ground water/	<ul style="list-style-type: none"> ▪ Conjunctive use of ground/surface water, to prevent flooding/water logging/depletion of water resources. Included are land use pattern, land filling, lagoon/reservoir/garland canal

Operational Aspects of EIA

Surface water)	<p>construction, and rainwater harvesting and pumping rate.</p> <ul style="list-style-type: none"> ▪ Stormwater drainage system to collect surface runoff ▪ Minimise flow variation from the mean flow ▪ Storing of oil wastes in lagoons should be minimised in order to avoid possible contamination of the ground water system. ▪ All effluents containing acid/alkali/organic/toxic wastes should be properly treated. ▪ Monitoring of ground waters ▪ Use of biodegradable or otherwise readily treatable additives ▪ Neutralization and sedimentation of wastewaters, where applicable ▪ Dewatering of sludges and appropriate disposal of solids ▪ In case of oil waste, oil separation before treatment and discharge into the environment ▪ By controlling discharge of sanitary sewage and industrial waste into the environment ▪ By avoiding the activities that increases erosion or that contributes nutrients to water (thus stimulating alga growth) ▪ For wastes containing high TDS, treatment methods include removal of liquid and disposal of residue by controlled landfilling to avoid any possible leaching of the fills ▪ All surface runoffs around mines or quarries should be collected treated and disposed. ▪ Treated wastewater (such as sewage, industrial wastes, or stored surface runoffs) can be used as cooling water makeup. ▪ Wastewater carrying radioactive elements should be treated separately by means of de-watering procedures, and solids or brine should be disposed of with special care. ▪ Develop spill prevention plans in case of chemical discharges and spills ▪ Develop traps and containment system and chemically treat discharges on site
Air Pollution	<ul style="list-style-type: none"> ▪ Periodic checking of vehicles and construction machinery to ensure compliance to emission standards ▪ Attenuation of pollution/protection of receptor through green belts/green cover ▪ Dilution of odourant (dilution can change the nature as well as strength of an odour), odour counteraction or neutralise (certain pairs of odours in appropriate concentrations may neutralise each other), odour masking or blanketing (certain weaker malodours may be suppressed by a considerably stronger good odour). ▪ Regular monitoring of air polluting concentrations
Dust pollution	<ul style="list-style-type: none"> ▪ Adopt sprinkling of water ▪ Wetting of roadways to reduce traffic dust and reentrained particles ▪ Control vehicle speed on sight ▪ Ensure priodical wahsing of cosntruction equipment and transport vehicles to prevent accumulated dust ▪ Ensure that vehicles should be covered during transportation ▪ Installation of windscreens to breakup the wind flow ▪ Burning of refuse on days when meteorological conditions provide for good mixing and dispersion ▪ Providing dust collection equipment at all possible points ▪ Maintaining dust levels within permissible limits ▪ Provision for masks when dust level exceeds

Noise pollution	<ul style="list-style-type: none"> ▪ Use of suitable muffler systems/enclosures/sound-proof glass panelling on heavy equipment/pumps/blowers ▪ Pumps and blowers may be mounted on rubber pads or any other noise absorbing materials ▪ Limiting certain activities ▪ Proper scheduling of high noise generating activities to minimise noise impacts ▪ Usage of well maintained construction equipment meeting the regulatory standards ▪ Placement of equipments emitting high noise in an orientation that directs the noise away from sensitive receptors ▪ Periodic maintenance of equipments/repalcing whenever necessary/lubrication of rotating parts, <i>etc.</i> ▪ By using damping, absorption, dissipation, and deflection methods ▪ By using common techniques such as constructing sound enclosures, applying mufflers, mounting noise sources on isolators, and/or using materials with damping properties ▪ Performance specifications for noise represent a way to insure the procured item is controlled ▪ Use of ear protective devices. ▪ In case of steady noise levels above 85-dB (A), initiation of hearing conservation measures ▪ Implementation of greenbelt for noise attenuation may be taken up
Biological	<ul style="list-style-type: none"> ▪ Installation of systems to discourage nesting or perching of birds in dangerous environments ▪ Increased employee awareness to sensitive areas
Social	<ul style="list-style-type: none"> ▪ Health and safety measures for workers ▪ Development of traffic plan that minimizes road use by workers ▪ Upgrade of roads and intersections ▪ Provide sufficient counselling and time to the affected population for relocation ▪ Discuss and finalize alternate arrangements and associated infrastructure in places of religious importance ▪ Exploration of alternative approach routes in consultation with local community and other stakeholders ▪ Provision of alternate jobs in unskilled and skilled categories
Marine	<ul style="list-style-type: none"> ▪ Water quality monitoring program ▪ Limit construction activities to day time to provide recuperation time at night and reduce turbidity ▪ Prevention of spillage of diesel, oil, lubes, <i>etc.</i> ▪ Usage of appropriate system to barges/workboats for collection of liquid/solid waste generated onboard ▪ Avoid discharge of construction/dredging waste (lose silt) into sea. It may be disposed at the identified disposal point. ▪ Ensure usage of suitable/proper equipment for dredging in order to minimize the turbidity and suspensions at the dredging site. ▪ Checking with the complainace conditions before discharging wastes into the sea water ▪ Have a post-dredging monitoring programme in place ▪ Take up periodic maintenance dredging including inspection of sub-sea conditions, <i>etc.</i>
Occupational health and safety	<ul style="list-style-type: none"> ▪ Provision of worker camps with proper sanitation and medical facilities, as well as making the worker camps self- sufficient with

	<p>resources like water supply, power supply, etc</p> <ul style="list-style-type: none"> ▪ Arrangement of periodic health check-ups for early detection and control of communicable diseases. ▪ Arrangement to dispose off the wastes at approved disposal sites. ▪ Provide preventive measures for potential fire hazards with requisite fire detection, fire-fighting facilities and adequate water storage
Construction	<ul style="list-style-type: none"> ▪ Have a Transport Management Plan in place in order to prevent/minimize the disturbance on surrounding habitats ▪ Initiate traffic density studies
Solid/Hazardous waste	<ul style="list-style-type: none"> ▪ Proper handling of excavated soil ▪ Proper plan to collect and dispose off the solid waste generated onsite. ▪ Identify an authorized waste handler for segregation of construction and hazardous waste and its removal on a regular basis to minimise odour, pest and litter impacts ▪ Prohibit buring of refuse onsite.

4.8 Environmental Management Plan

A typical EMP shall be composed of the following:

1. summary of potential impacts of the proposal
2. description of recommended mitigation measures
3. description of monitoring programme to ensure compliance with relevant standards and residual impacts
4. allocation of resources and responsibilities for plan implementation
5. implementation schedule and reporting procedures
6. contingency plan when impacts are greater than expected

Summary of impacts: The predicted adverse environmental and social impacts for which mitigation measures are identified in earlier sections to be briefly summarized with cross referencing to the corresponding sections in EIA report.

Description of mitigation measures: Each mitigation measure should be briefly described w.r.t the impact to which it relates and the conditions under which it is required. These should be accompanied by/referenced to, project design and operating procedures which elaborate on the technical aspects of implementing various measures.

Description of monitoring programme to ensure compliance with relevant standards and residual impacts: Environmental monitoring refers to compliance monitoring and residual impact monitoring. Compliance monitoring refers to meeting the industry-specific statutory compliance requirements (Ref. Applicable National regulations as detailed in Chapter 3).

Residual impact monitoring refers to monitoring of identified sensitive locations with adequate number of samples and frequency. The monitoring programme should clearly indicate the linkages between impacts identified in the EIA report, measurement

indicators, detection limits (where appropriate), and definition of thresholds that signal the need for corrective actions.

Allocation of resources and responsibilities for plan implementation: These should be specified for both the initial investment and recurring expenses for implementing all measures contained in the EMP, integrated into the total project costs, and factored into loan negotiation.

The EMP should contain commitments that are binding on the proponent in different phases of project implementation i.e., pre-construction or site clearance, construction, operation, decommissioning.

Responsibilities for mitigation and monitoring should be clearly defined, including arrangements for coordination between various actors responsible for mitigation. Details should be provided w.r.t deployment of staff (detailed organogram), monitoring network design, parameters to be monitored, analysis methods, associated equipments, i.

Implementation schedule and reporting procedures: The timing, frequency and duration of mitigation measure should be specified in an implementation schedule, showing links with overall project implementation. Procedures to provide information on progress and results of mitigation and monitoring measures should also be clearly specified.

Contingency Plan when the impacts are greater than expected: There shall be a contingency plan for attending the situations where the residual impacts are higher than expected. It is an imperative requirement for all project Authorities to plan additional programmes to deal with the situation, after duly intimating the concerned local regulatory bodies.

4.8.1 Monitoring requirement

In the process of cement manufacture, apart from monitoring masses, air flow, temperature and pressure as required for operational and process control, measurements of gaseous emissions are required for;

Exit gas analyses

Continuous measurement for CO, CO₂ and oxygen. Occurrence of CO indicates incomplete combustion of fuel; it should be as low as possible. The desirable limit is 1000 ppm maximum at kiln inlet and 500 ppm at preheater exit. Presence of oxygen indicates complete combustion, but excess of that required for burning is indicative of excess air supply with concomitant increase in thermal energy consumption; the desirable limit is maximum of 2 % at kiln inlet/PC outlet and 4 % at preheater exit. The amount of CO₂ should be as high as possible, because it indicates complete decarbonation (calcination) of kiln feed and combustion of fuel. Gas analysers are employed for measurements.

Dust measurements for pollution control

To accurately quantify the emissions, continuous measurements of dust volume are monitored, to be within the limits prescribed by SPCB. This is measured with dust samplers.

- In case of waste derived fuels - The parameters that are required to be evaluated are NO_x, SO₂, CO, CO₂, H₂O, HCl, HF, NH₃, C₆H₆, O₂, TOC, Dioxins/furans on the one hand and heavy metals like Antimony, Arsenic, Cadmium, Chromium, Cobalt, Copper, Lead, Manganese, Mercury, Nickel, Thallium and Vanadium. These are required both for emissions and for characterizing the waste prior to use. The methods are common chemical analysis for some, while others require chromatography and spectrophotometer methods.

Use of common analytical facilities

Both, gas analysers and dust samplers are available with cement plants. However, other analytical methods may not be available in-house for cement plants desirous of using waste derived fuels. Common facilities at some laboratories may have to be used. Cement machinery manufacturers, who provide solutions for characterization and use of waste-derived fuels including added burners, combustion chambers, burning module *etc.*, also provide necessary test facilities. In some countries, advanced electronic means are used to monitor cement plant emissions automatically 24/7 in a central facility.

Co-operation in use of AFR

Another instance of necessary co-operation between cement producer, authorities and the public arise in case of use of waste materials as fuel and raw materials. There may be a perception that such co-processing is nothing other than dumping of wastes, including hazardous ones into the kiln and then to the environment through emissions. It is expected that there should be complete transparency in such uses. Yet, this may lead to objections at the stage of public consultation who may object ‘Not in my backyard’ (NIMBY). It has to be emphasized that use of AFR is a strictly regulated process and there is no significant difference in the emission behavior than when no waste materials are burnt. The authorities have to come forward to educate the people that such use of waste materials makes profound sense from environmental, economic and sustainability considerations. Co-operation of different authorities is required also in case of trans-boundary shipment, and application of ‘proximity principle’ for disposal in case of different tax regimes.

4.9 Reporting

Structure of the EIA report (Appendix III of the EIA Notification), applicable for Cement plants is given in the Table 4-6 Each task prescribed in ToR shall be incorporated appropriately in the contents in addition to the contents described in the following table.

Table 4-6: Structure of EIA Report

S.NO	EIA STRUCTURE	CONTENTS
1	Introduction	<ul style="list-style-type: none"> ▪ Purpose of the report ▪ Identification of project & project proponent ▪ Brief description of nature, size, location of the project and its importance to the country, region ▪ Scope of the study – details of regulatory scoping carried out (As per Terms of Reference)
2	Project Description	Condensed description of those aspects of the project (based on project feasibility study), likely to cause environmental effects Details should be provided to give clear picture of the following:

S.NO	EIA STRUCTURE	CONTENTS
		<ul style="list-style-type: none"> ▪ Type of project ▪ Need for the project ▪ Location (maps showing general location, specific location, project boundary & project site layout) ▪ Size or magnitude of operation (incl. Associated activities required by / for the project) ▪ Proposed schedule for approval and implementation ▪ Technology and process description ▪ Project description including drawings showing project layout, components of project <i>etc.</i> Schematic representations of feasibility drawings which give information important for EIA ▪ Description of mitigation measures incorporated into the project to meet environmental standards, environmental operating conditions, or other EIA requirements (as required by the scope) ▪ Assessment of new & untested technology for the risk of technological failure
3	Description of the Environment	<ul style="list-style-type: none"> ▪ Study area, period, components & methodology ▪ Establishment of baseline for VECs, as identified in the scope ▪ Base maps of all environmental components
4	Anticipated Environmental Impacts & Mitigation Measures	<ul style="list-style-type: none"> ▪ Details of investigated environmental impacts due to project location, possible accidents, project design, project construction, regular operations, final decommissioning or rehabilitation of a completed project ▪ Measures for minimizing and / or offsetting adverse impacts identified ▪ Irreversible and irretrievable commitments of environmental components ▪ Assessment of significance of impacts (Criteria for determining significance, assigning significance) ▪ Mitigation measures
5	Analysis of Alternatives (Technology & Site)	<p>In case, the scoping exercise results in need for alternatives:</p> <ul style="list-style-type: none"> ▪ Description of each alternative ▪ Summary of adverse impacts of each alternative ▪ Mitigation measures proposed for each alternative and selection of alternative
6	Environmental Monitoring Program	<ul style="list-style-type: none"> ▪ Technical aspects of monitoring the effectiveness of mitigation measures (incl. measurement methodologies, frequency, location, data analysis, reporting schedules, emergency procedures, detailed budget & procurement schedules)
7	Additional Studies	<ul style="list-style-type: none"> ▪ Public consultation ▪ Risk assessment ▪ Social impact assessment, R&R Action Plans
8	Project Benefits	<ul style="list-style-type: none"> ▪ Improvements in physical infrastructure ▪ Improvements in social infrastructure ▪ Employment potential –skilled; semi-skilled and unskilled ▪ Other tangible benefits
9	Environmental Cost Benefit Analysis	<ul style="list-style-type: none"> ▪ If recommended at the Scoping stage
10	EMP	<ul style="list-style-type: none"> ▪ Description of administrative aspects that ensure proper

S.NO	EIA STRUCTURE	CONTENTS
		implementaion of the mitigative measures and their effectiveness monitored, after approval of the EIA
11	Summary & Conclusion (This will constitute the summary of the EIA Report)	<ul style="list-style-type: none"> ▪ Overall justification for implementation of the project ▪ Explanation of how, adverse effects have been mitigated
12	Disclosure of Consultants engaged	<ul style="list-style-type: none"> ▪ Names of the Consultants engaged with their brief resume and nature of Consultancy rendered

4.10 Public Consultation

Public consultation refers to the process by which the concerns of local affected people and others who have plausible stake in the environmental impacts of the project or activity are ascertained

- Public consultation is not a decision taking process, but is a process to collect views of the people having plausible stake. If the SPCB/Public agency conducting public hearing is not convinced with the plausible stake, then such expressed views need not be considered
- Public consultation involves two components, one is public hearing, and other one is inviting written responses/objections through Internet/by post, *etc*, by placing the summary of EIA report on the web site.
- All Category A and Category B1 projects require public hearing except the following:
 - Once environmental clearance is granted to an industrial estate/SEZ/EPZ *etc*, for a given composition (type and capacity) of industries, then individual units will not require public hearing
 - Expansion of roads and highways, which do not involve any further acquisition of land
 - Maintenance dredging provided the dredged material shall be disposed within port limits
 - All building/ construction projects/ area development projects/townships
 - All Category B2 projects
 - All projects concerning national defense and security or involving other strategic considerations as determined by the Central Government
- Public hearing shall be carried out at the site or in its close proximity, district-wise, for ascertaining concerns of local affected people
- Project proponent shall make a request through a simple letter to the Member–Secretary of the SPCB or UTPCC to arrange public hearing
- Project proponent shall enclose with the letter of request, at least 10 hard copies and 10 soft copies of the draft EIA report including the summary EIA report in English and in official language of the State/local language prepared as per the approved scope of work, to the concerned Authority
- Simultaneously, project proponent shall arrange to send, one hard copy and one soft copy, of the above draft EIA report along with the summary EIA report to the following Authorities within whose jurisdiction the project will be located:
 - District magistrate(s)/District Collector/Deputy Commissioner (s)

- Zilla parishad and municipal corporation or panchayats union
 - District industries office
 - Urban local bodies (ULBs)/PRIs concerned/development authorities
 - Concerned regional office of the MoEF/SPCB
- Above mentioned Authorities except regional office of MoEF shall arrange to widely publicize the draft EIA report within their respective jurisdictions requesting the interested persons to send their comments to the concerned regulatory Authorities. They shall also make draft EIA report for inspection electronically or otherwise to the public during normal office hours till the public hearing is over.
 - Concerned regulatory Authority (MoEF/SEIAA/UTEIA) shall display the summary of EIA report on its website and also make full draft EIA report available for reference at a notified place during normal office hours at their head office.
 - SPCB or UTPCC concerned shall also make similar arrangements for giving publicity about the project within the State/UT and make available the summary of draft EIA report for inspection in select offices, public libraries or any other suitable location, etc. They shall also additionally make available a copy of the draft EIA report to the five authorities/offices as mentioned above..
 - The Member–Secretary of the concerned SPCB or UTPCC shall finalize the date, time and exact venue for the conduct of public hearing within seven days of the date of the receipt of the draft EIA report from the project proponent and advertise the same in one major National Daily and one Regional vernacular Daily/official State language.
 - A minimum notice period of 30 (thirty) days shall be provided to the public for furnishing their responses.
 - No postponement of the date, time, venue of the public hearing shall be undertaken, unless some untoward emergency situation occurs. Only in case of emergencies and on the recommendation of the concerned District Magistrate/District Collector/Deputy Commissioner (s) the postponement shall be notified to the public through the same National and Regional vernacular dailies and also prominently displayed at all the identified offices by the concerned SPCB or UTPCC
 - In the above exceptional circumstances fresh date, time and venue for the public consultation shall be decided by the Member–Secretary of the concerned SPCB or UTPCC only in consultation with the District Magistrate/District Collector/Deputy Commissioner (s) and notified afresh as per the procedure.
 - The District Magistrate/District Collector/Deputy Commissioner (s) or his or her representative not below the rank of an Additional District Magistrate assisted by a representative of SPCB or UTPCC, shall supervise and preside over the entire public hearing process.
 - The SPCB or UTPCC shall arrange to video film the entire proceedings. A copy of the videotape or a CD shall be enclosed with the public hearing proceedings while forwarding it to the Regulatory Authority concerned.
 - The attendance of all those who are present at the venue shall be noted and annexed with the final proceedings
 - There shall be *no quorum* required for attendance for starting the proceedings
 - Persons present at the venue shall be granted the opportunity to seek information or clarifications on the project from the proponent. The summary of the public hearing proceedings accurately reflecting all the views and concerns expressed shall be

recorded by the representative of the SPCB or UTPCC and read over to the audience at the end of the proceedings explaining the contents in the local/vernacular language and the agreed minutes shall be signed by the District Magistrate/District Collector/Deputy Commissioner (s) or his or her representative on the same day and forwarded to the SPCB/UTPCC concerned.

- A statement of the issues raised by the public and the comments of the proponent shall also be prepared in the local language or the official State language, as the case may be and in English and annexed to the proceedings.
- The proceedings of the public hearing shall be conspicuously displayed at the office of the Panchayats within whose jurisdiction the project is located, office of the concerned Zilla Parishad, District Magistrate/District Collector/Deputy Commissioner (s), and the SPCB or UTPCC. The SPCB or UTPCC shall also display the proceedings on its website for general information. Comments, if any, on the proceedings, may be sent directly to the concerned regulatory authorities and the Applicant concerned.
- The public hearing shall be completed within a period of 45 (forty five) days from date of receipt of the request letter from the Applicant. Therefore the SPCB or UTPCC concerned shall send public hearing proceedings to the concerned regulatory authority within eight (8) days of the completion of public hearing. Simultaneously, a copy will also be provided to the project proponent. The proponent may also directly forward a copy of the approved public hearing proceedings to the regulatory authority concerned along with the final EIA report or supplementary report to the draft EIA report prepared after the public hearing and public consultations incorporating the concerns expressed in the public hearing along with action plan and financial allocation, item-wise, to address those concerns
- Up on receipt of the same, the Authority will place executive summary of the report on the website to invite responses from other concerned persons having a plausible stake in the environmental aspects of the project or activity
- If SPCB/UTPCC is unable to conduct public hearing in the prescribed time, the Central Government in case of Category A projects and State Government or UT administration in case of Category B projects at the request of SEIAA may engage any other agency or authority for conducting the public hearing process within a further period of 45 days. The respective governments shall pay appropriate fee to the public agency for conducting public hearing.
- A public agency means a non-profit making institution/ body such as technical/academic institutions, government bodies not subordinate to the concerned Authority
- If SPCB/Public Agency authorized for conducting public hearing informs the Authority, stating that it is not possible to conduct the public hearing in a manner, which will enable the views of the concerned local persons to be freely expressed, then Authority may consider such report to take a decision that in such particular case, public consultation may not have the component of public hearing
- Often restricting the public hearing to the specific district may not serve the entire purpose, therefore, NGOs who are local and registered under the Societies Act in the adjacent districts may also be allowed to participate in public hearing, if they so desire
- Confidential information including non-disclosable or legally privileged information involving intellectual property right, source specified in the application shall not be placed on the website

- The Authority shall make available, on a written request from any concerned person, the draft EIA report for inspection at a notified place during normal office hours till the date of the public hearing
- While mandatory requirements will have to be adhered to, utmost attention shall be given to the issues raised in the public hearing for determining the modifications needed in the project proposal and the EMP to address such issues
- Final EIA report after making needed amendments, as aforesaid, shall be submitted by the applicant to the concerned Authority for prior environmental clearance. Alternatively, a supplementary report to draft EIA and EMP addressing all concerns expressed during the public consultation may be submitted

4.11 Appraisal

Appraisal means the detailed scrutiny by the EAC or SEAC of the application and the other documents like the final EIA report, outcome of the public consultation including public hearing proceedings submitted by the applicant for grant of environmental clearance

- The appraisal shall be made by EAC to the Central Government or SEAC to SEIAA
- Project proponent either personally or through consultant can make a presentation to EAC/SEAC for the purpose of appraising the features of the project proposal and also to clarify the issues raised by the members of the EAC/SEAC
- On completion of these proceedings, concerned EAC/SEAC shall make categorical recommendations to the respective Authority, either for grant of prior environmental clearance on stipulated terms & conditions, if any, or rejection of the application with reasons
- In case EAC/SEAC needs to visit the site or obtain further information before being able to make categorical recommendations, EAC/SEAC may inform the project proponent accordingly. In such an event, it should be ensured that the process of environmental clearance is not unduly delayed to go beyond the prescribed timeframe
- Up on the scrutiny of the final report, if EAC/SEAC opines that ToR for EIA studies finalized at the scoping stage are covered by the proponent, then the project proponent may be asked to provide such information. If such information is declined by the project proponent or is unlikely to be provided early enough so as to complete the environmental appraisal within prescribed time of 60 days, the EAC/SEAC may recommend for rejection of the proposal with the same reason
- Appraisal shall be strictly in terms of ToR for EIA studies finalized at the scoping stage and the concerns expressed during public consultation
- This process of appraisal shall be completed within 60 days from receipt of the updated EIA and EMP reports, after completing public consultation
- The EIA report will be typically examined for following:
 - Project site description supported by topographic maps & photographs – detailed description of topography, land use and activities at the proposed project site and its surroundings (buffer zone) supported by photographic evidence
 - Clarity in description of drainage pattern, location of eco-sensitive areas, vegetation characteristics, wildlife status - highlighting significant environmental attributes such as feeding, breeding and nesting grounds of wildlife species, migratory corridor, wetland, erosion and neighboring issues.

- Description of the project site – how well the interfaces between the project related activities and the environment have been identified for the entire project cycle i.e. construction, operation and decommissioning at the end of the project life.
- If it is envisaged that the project is to be closed after a specified period in case of mining projects, the interface at the closure stage also needs to be described.
- How complete and authentic are the baseline data pertaining to flora and fauna and socio economic aspects?
- Citing of proper references, with regard to the source(s) of baseline data as well as the name of the investigators/ investigating agency responsible for collecting the primary data.
- How consistent are the various values of environmental parameters with respect to each other?
- Is a reasonable assessment of the environmental and social impact made for the identified environmental issues including project affected people?
- To what extent the proposed environmental plan will mitigate the environmental impact and at what estimated cost, shown separately for construction, operation and closure stages and also separately in terms of capital and recurring expenses along with details of agencies that will be responsible for the implementation of environmental plan/ conservation plan.
- How well the concerns expressed/highlighted during the public hearing have been addressed and incorporated in the EMP giving item wise financial provisions and commitments (in quantified terms)?
- How far the proposed environmental monitoring plan will effectively evaluate the performance EMP's? Are details for environmental monitoring plan provided in the same manner as the EMP?
- Identification of hazard and quantification of risk assessment and whether appropriate mitigation plan has been included in the EMP?
- Does the proposal include a well formulated time bound green belt development plan for mitigating environmental problems such as fugitive emissions of dust, gaseous pollutants, noise, odour, *etc.*?
- Does EIA make a serious attempt to guide the project proponent for minimizing the requirement of natural resources including land, water energy and other non renewable resources?
- How well has the EIA statement been organized and presented so that the issues, their impact and environmental management strategies emerge clearly from it and how well organized was the power point presentation made before the expert committee?
- Is the information presented in EIA adequately and appropriately supported by maps, imageries and photographs highlighting site features and environmental attributes?

4.12 Decision Making

The Chairperson reads the sense of the Committee and finalizes the draft minutes of the meeting, which are circulated by the Secretary to all expert members invited to the meeting. Based on the response from the members, the minutes are finalized and signed

by the Chairperson. This process for finalization of the minutes should be so organized that the time prescribed for various stages is not exceeded.

Approval / Rejection / Reconsideration

- The Authority shall consider the recommendations of concerned appraisal Committee and convey its decision within 45 days of the receipt of recommendations
- If the Authority disagrees with the recommendations of the Appraisal Committee, then reasons shall be communicated to concerned Appraisal Committee and applicant within 45 days from the receipt of the recommendations. The Appraisal Committee concerned shall consider the observations of the Authority and furnish its views on the observations within further period of 60 days. The Authority shall take a decision within the next 30 days based on the views of appraisal Committee
- If the decision of the Authority is not conveyed within the time, then the proponent may proceed as if the environmental clearance sought has been granted or denied by the regulatory authority in terms of the final recommendation of the concerned appraisal Committee. For this purpose, the decision of the Appraisal Committee will be a public document, once the period specified above for taking the decision by the Authority is over
- In case of the Category B projects, application shall be received by the Member–Secretary of the SEIAA and clearance shall also be issued by the same SEIAA
- Deliberate concealment and/or submission of false or misleading information or data which is material to screening or scoping or appraisal or decision on the application shall make the application liable for rejection, and cancellation of prior environmental clearance granted on that basis Rejection of an application or cancellation of a prior environmental clearance already granted, on such ground, shall be decided by the regulatory authority, after giving a personal hearing to the applicant, and following the principles of natural justice

If approved

- MoEF or concerned SEIAA will issue the environmental clearance for the project
- The project proponent should make sure that the award of environmental clearance is properly publicized in at least two local newspapers of the district or state where the proposed project is located For instance, the executive summary of the environmental clearance may be published in the newspaper along with the information about the location (website/office where it is displayed for public) where the detailed environmental clearance is made available The MoEF and SEIAA/UTEIAA, as the case may be, shall also place the environmental clearance in the public domain on Government Portal. Further copies of the environmental clearance shall be endorsed to the Heads of local bodies, Panchayats and Municipal bodies in addition to the relevant offices of the Government
- The environmental clearance will be valid from the start date to actual commencement of the production of the developmental activity
- Usual validity period will be 5 years from the date of issuing environmental clearance, unless specified by EAC/SEAC.
- A prior environmental clearance issued to a project proponent can be transferred to another legal person entitled to undertake the project, upon application by the

transferor to the concerned Authority or submission of no-objection of the transferor by the transferee to the concerned Authority for the concurrence. In this case, EAC/SEAC concurrence is not required, but approval from the concerned authority is required to avail the same project configurations, validity period transferred to the new legally entitled person to undertake the project.

4.13 Post-clearance Monitoring Protocol

The MoEF, Government of India will monitor and take appropriate action under the EP Act, 1986.

- In respect of Category A projects, it shall be mandatory for the project proponent to make public the environmental clearance granted for their project along with the environmental conditions and safeguards at their cost by advertising it at least in two local newspapers of the district or State where the project is located and in addition, this shall also be displayed in the project proponent's website permanently.
- In respect of Category B projects, irrespective of its clearance by MoEF/SEIAA, the project proponent shall prominently advertise in the newspapers indicating that the project has been accorded environment clearance and the details of MoEF website where it is displayed.
- The MoEF and the SEIAAs/UTEIAAs, as the case may be, shall also place the environmental clearance in the public domain on Government Portal.
- Copies of the environmental clearance shall be submitted by the project proponents to the Heads of the local bodies, Panchayats and Municipal bodies in addition to the relevant offices of the Government who in turn have to display the same for 30 days from the date of receipt.

The project proponent must submit half-yearly compliance reports in respect of the stipulated prior environmental clearance terms and conditions in hard and soft copies to the regulatory authority concerned, on 1st June and 1st December of each calendar year.

All such compliance reports submitted by the project management shall be public documents. Copies of the same shall be given to any person on application to the concerned regulatory authority. Such latest such compliance report shall also be displayed on the web site of the concerned regulatory Authority.

The SPCB shall incorporate EIA clearance conditions into consent conditions in respect of Category A and Category B projects and in parallel monitor and enforce the same.

5.

STAKEHOLDERS' ROLES AND RESPONSIBILITIES

Prior environmental clearance process involves many stakeholders i.e. , Central Government, State Government, SEIAA, EAC at the National Level, SEAC, Public Agency, SPCB, the project proponent, and the public

- Roles and responsibilities of the organizations involved in different stages of prior environmental clearance are listed in Table 5-1
- Organization-specific functions are listed in Table 5-2

In this Chapter, constitution, composition, functions, *etc.*, of the Authorities and the Committees are discussed in detail

Table 5-1: Roles and Responsibilities of Stakeholders Involved in Prior Environmental Clearance

STAGE	MoEF/ SEIAA	EAC/ SEAC	PROJECT PROPONENT	EIA CONSULTANT	SPCB/ PUBLIC AGENCY	PUBLIC AND INTEREST GROUP
Screening	Receives application and takes advice of EAC/ SEAC	Advises the MoEF/ SEIAA	Submits application (Form 1) and provides necessary information	Advises and assists the proponent by providing technical information		
Scoping	Approves the ToR, communicates the same to the project proponent and places the same in the website	Reviews the ToR, visits the proposed site, if required, and recommends the ToR to the MoEF/ SEIAA	Submits the draft ToR to SEIAA and facilitates the visit of the EAC/SEAC members to the project site	Prepares ToR		
EIA Report & Public Hearing	Reviews and forwards copies of the EIA report to SPCB /public agency for conducting public hearing		Submits detailed EIA report as per the finalized ToR Facilitates the public hearing by arranging presentation on the project, EIA and EMP – takes note of objections and	Prepares the EIA report Presents and appraises the likely impacts and pollution control measures proposed in the public hearing	Reviews EIA report and conducts public hearing in the manner prescribed Submits proceedings and views of	Participates in public hearings and offers comments and observations Comments can be sent directly to SEIAA

Stakeholders' Roles and Responsibilities

STAGE	MoEF/ SEIAA	EAC/ SEAC	PROJECT PROPONENT	EIA CONSULTANT	SPCB/ PUBLIC AGENCY	PUBLIC AND INTEREST GROUP
	Places the summary of EIA report in the website Conveys objections to the project proponent for update, if any		updates the EMP accordingly		SPCB, to the Authority and the project proponent as well	through Internet in response to the summary placed in the website
Appraisal and Clearance	Receives updated EIA Takes advice of EAC/SEAC, approves EIA and attaches the terms and conditions	Critically examines the reports, presentation of the proponent and appraises MoEF/SEIAA (recommendations are forwarded to MoEF/SEIAA)	Submits updated EIA, EMP reports to MoEF/SEIAA. Presents the overall EIA and EMP including public concerns to EAC/SEAC	Provides technical advise to the project proponent and if necessary presents the proposed measures for mitigation of likely impacts (terms and conditions of clearance)		
Post-clearance Monitoring			Implements environmental protection measures prescribed and submits periodic monitoring results	Conducts periodic monitoring	Incorporates the clearance conditions into appropriate consent conditions and ensures implementation	

Table 5-2: Organization-specific Functions

ORGANIZATION	FUNCTIONS
Central Government	<ul style="list-style-type: none"> ▪ Constitutes the EAC ▪ Considering recommendations of the State Government, constitutes the SEIAA & SEAC ▪ Receives application from the project proponent in case of Category A projects or Category B projects attracting general condition ▪ Communicates the ToR finalized by the EAC to the project proponent. ▪ Receives EIA report from the project proponent and soft copy of summary of the report for placing in the website

Stakeholders' Roles and Responsibilities

ORGANIZATION	FUNCTIONS
	<ul style="list-style-type: none"> ▪ Summary of EIA report will be placed in website. Forwards the received responses to the project proponent ▪ Engages other public agency for conducting public hearings in cases where the SPCB does not respond within time ▪ Receives updated EIA report from project proponent incorporating the considerations from the proceedings of public hearing and responses received through other media ▪ Forwards updated EIA report to the EAC for appraisal ▪ Either accepts the recommendations of EAC or asks for reconsideration of specific issues for review by the EAC ▪ Takes the final decision – acceptance/ rejection – of the project proposal and communicates the same to the project proponent
State Government	<ul style="list-style-type: none"> ▪ Identifies experts as per the composition specified in the Notification and subsequent guidelines to recommend to the the Central Government. ▪ Extends funding support to fulfill the functions of SEIAA/SEAC ▪ Engages other public agency for conducting public hearings in cases where the SPCB does not respond within time ▪ State Governments will suitably pay the public agency for conducting such activity
EAC	<ul style="list-style-type: none"> ▪ Reviews Form 1 and its attachments ▪ Visits site(s), if necessary ▪ Finalizes ToR and recommends to the Central Government, which in turn communicates the finalized ToR to the project proponent, if not exempted by the Notification ▪ Reviews EIA report, proceedings and appraises their views to the Central government ▪ If the Central Government has any specific views, then the EAC reviews again for appraisal
SEIAA	<ul style="list-style-type: none"> ▪ Receives application from the project proponent ▪ Considers SEAC's views for finalization of ToR ▪ Communicates the finalized ToR to the project proponent ▪ Receives EIA report from project proponent ▪ Uploads the summary of EIA report in the website in cases of Category B projects ▪ Forwards the responses received to the project proponent ▪ Receives updated EIA report from project proponent incorporating the considerations from the proceedings of public hearing and responses received through other media ▪ Forwards updated EIA report to SEAC for appraisal ▪ Either accepts the recommendations of SEAC or asks for reconsideration of specific issues for review by SEAC ▪ Takes the final decision and communicates the same to the project proponent
SEAC	<ul style="list-style-type: none"> ▪ Reviews Form 1 ▪ If necessary visits, site(s) for finalizing the ToR ▪ Reviews updated EIA - EMP report and ▪ Appraises the SEIAA
SPCB	<ul style="list-style-type: none"> ▪ Receives request from project proponent and conducts public hearing in the manner prescribed ▪ Conveys proceedings to concerned authority and project proponent
Public Agency	<ul style="list-style-type: none"> ▪ Receives request from the respective Governments to conduct public hearing ▪ Conducts public hearing in the manner prescribed ▪ Conveys proceedings to the concerned Authority/EAC /Project proponent

5.1 SEIAA

- SEIAA is constituted by the MoEF to take final decision regarding the acceptance/rejection of prior environmental clearance to the project proposal for all Category 'B' projects
- The state government may decide whether to house them at the Department of Environment or at any other Board for effective operational support
- State Governments can decide whether the positions are permanent or part-time. The Central Government (MoEF) continues to follow the model of paying fee (TA/DA, accommodation, sitting fee) to the Chairperson and the members of EAC. As such, the State Government is to fund SEIAA & SEAC and decide the appropriate institutional support for them.

A Constitution

- SEIAA is constituted by the Central Government comprising of three members including a Chairperson and Member–Secretary to be nominated by the State Government or UT Administration concerned
- The Central Government will notify as and when the nominations (in order) are received from the State Governments, within 30 days from the date of receipt
- The Chairperson and the non-official member shall have a fixed term of three years, from the date of Notification by the Central Government constituting the Authority.

The form used by the State Governments to submit nominations for Notification by the Central Government is provided in **Annexure XI**

B Composition

- Chairperson shall be an expert in the EIA process
- Member–Secretary shall be a serving officer of the concerned State Government/ UT Administration familiar with the environmental laws.
- Member–Secretary may be of a level equivalent to the Director, Dept. of Environment or above – a full time member.
- All the members including the Chairperson shall be the experts as per the criteria set in the Notification.
- The Government servants can only serve as the Member–Secretary to SEIAA and the Secretary to SEAC. All other members including Chairperson of the SEIAA and SEAC shall not be comprised of serving Government Officers; industry representatives; and the activists.
- Serving faculty (academicians) is eligible for the membership in the Authority and/or the Committees, if they fulfill the criteria given in Appendix VI to the Notification.
- This is to clarify that the serving Government officers shall not be nominated as professional/expert member of SEIAA/SEAC/EAC.
- Professionals/Experts in the SEIAA and SEAC shall be different.

Summary regarding the eligibility criteria for Chairperson and Members of the SEIAA is given in Table 5-3.

C Decision-making process

- The decision of the Authority shall be arrived through consensus
- If there is no consensus, the Authority may either ask SEAC for reconsideration or may reject the approval
- All decisions of the SEIAA shall be taken in a meeting and shall ordinarily be unanimous, provided that, in case a decision is taken by majority, the details of views, for and against it, shall be clearly recorded in the minutes and a copy thereof sent to MoEF

Table 5-3: SEIAA: Eligibility Criteria for Chairperson/ Members/ Secretary

S. No.	Attribute		Requirement		
			Members	Member–Secretary	Chairperson
1	Professional qualification as per the Notification		Compulsory	Compulsory	Compulsory
2	Experience (Fulfilling any one of a, b, c)	a	Professional Qualification + 15 years of experience in one of the expertise area mentioned in the Appendix VI	Professional Qualification + 15 years of experience in one of the expertise area mentioned in the Appendix VI	Professional Qualification + 15 years of experience in one of the expertise area mentioned in the Appendix VI
		b	Professional Qualification +PhD+10 years of experience in one of the expertise area mentioned in Appendix VI	Professional Qualification +PhD+10 years of experience in one of the expertise area mentioned in the Appendix VI	Professional Qualification +PhD+10 years of experience in one of the expertise area mentioned in the Appendix VI
		c	Professional Qualification +10 years of experience in one of the expertise area mentioned in the Appendix VI + 5 years interface with environmental issues, problems and their management	Professional Qualification +10 years of experience in one of the expertise area mentioned in the Appendix VI + 5 years interface with environmental issues, problems and their management	-----
3	Test of independence (conflict of interest) and minimum grade of the Secretary of the Authority		Shall not be a serving government officer Shall not be a person engaged in industry and their associations Shall not be a person associated with environmental activism	Only serving officer from the State Government (DoE) familiar with environmental laws not below the level of Director	Shall not be a serving government officer Shall not be a person engaged in industry and their associations Shall not be a person associated with environmental activism

Stakeholders' Roles and Responsibilities

S. No.	Attribute	Requirement		
		Members	Member–Secretary	Chairperson
4	Age	Below 67 years at the time of Notification of the Authority	As per State Government Service Rules	Below 72 Years at the time of the Notification of the Authority
5	Other memberships in Central/State Appraisal Committee	Shall not be a member in any SEIAA/EAC/SEAC	Shall not be a member in any SEIAA/EAC/SEAC	Shall not be a member in any SEIAA/EAC/SEAC
6	Tenure of earlier appointment (continuous)	Only one term before this in continuity is permitted	Not applicable	Only one term before this in continuity is permitted
7	Eminent environmental expertise with understanding on environmental aspects and impacts	Desirable	Desirable	Compulsory
8	Expertise in the environmental clearance process	Desirable	Desirable	Compulsory

Note:

1. A member after continuous membership in two terms (6 years) shall not be considered for further continuation. His/her nomination may be considered after a gap of one term (three years), if other criteria meet.
2. Chairperson/Member once notified may not be removed prior to the tenure of three years without cause and proper enquiry

5.2 EAC and SEAC

EAC and SEAC are independent Committees to review each developmental activity and offer its recommendations for consideration of the Central Government and SEIAA respectively

A Constitution

- EAC and SEAC shall be constituted by the Central Government comprising a maximum of 15 members including a Chairperson and Secretary. In case of SEAC, the State Government or UT Administration is required to nominate the professionals/experts for consideration and Notification by the Central Government.
- The Central Government will notify as and when the nominations (in order) are received from the State Governments, within 30 days from the date of receipt.
- The Chairperson and the non-official member shall have a fixed term of three years, from the date of Notification by the Central Government.
- The Chairperson shall be an eminent environmental expert with understanding on environmental aspects and environmental impacts. The Secretary of the SEAC shall be a State Government officer, not below the level of a Director/Chief Engineer.

Stakeholders' Roles and Responsibilities

- The members of the SEAC need not be from the same State/UT.
- In case the State Governments/ Union Territories so desire, the MoEF can form regional EAC to serve the concerned States/Union Territories.
- State Governments may decide to their convenience to house SEAC at the Department of Environment or at SPCB or at any other department, to extend support to the SEAC activities.

B. Composition

- Composition of EAC/SEAC as per the Notification is given in **Annexure XII**.
- Secretary to EAC/SEAC may invite a maximum of two professionals/experts with the prior approval of the Chairperson, if desired, for taking the advisory inputs for appraisal. In such case, the invited experts will not take part in the decision making process.
- The Secretary of each EAC/SEAC preferably be an officer of the level equivalent to or above the level of Director, MoEF, GoI.

C. Decision making

The EAC and SEAC shall function on the principle of collective responsibility. The Chairperson shall endeavour to reach a consensus in each case, and if consensus cannot be reached, the view of the majority shall prevail.

D. Operational issues

- Secretary may deal with all correspondence, formulate agenda and prepare agenda notes. Chairperson and other members may act only for the meetings.
- Chairperson of EAC/SEAC shall be one among the core group having considerable professional experience with proven credentials.
- EAC/SEAC shall meet at least once every month or more frequently, if so needed, to review project proposals and to offer recommendations for the consideration of the Authority.
- EAC/SEAC members may inspect the site at various stages *i.e.*, during screening, scoping and appraisal, as per the need felt and decided by the Chairperson of the Committee.
- The respective Governments through the Secretary of the Committee may pay/reimburse the participation expenses, honorarium *etc.*, to the Chairperson and members.

i. Tenure of EAC/SEIAA/SEAC

The tenure of Authority/Committee(s) shall be for a fixed period of three years. At the end of the three years period, the Authority and the committees need to be re-constituted.. However, staggered appointment dates may be adopted to maintain continuity of members at a given point of time.

ii. Qualifying criteria for nomination of a member to EAC/SEIAA/SEAC

While recommending nominations and while notifying the members of the Authority and Expert Committees, it shall be ensured that all the members meet the following three criteria:

- Professional qualification
- Relevant experience/Experience interfacing with environmental management
- Absence of conflict of interest

These are elaborated subsequently.

a) Professional qualification

The person should have at least (i) 5 years of formal University training in the concerned discipline leading to a MA/MSc Degree, or (ii) in case of Engineering/Technology/Architecture disciplines, 4 years formal training in a professional training course together with prescribed practical training in the field leading to a B.Tech/B.E./B.Arch. Degree, or (iii) Other professional degree (e.g. Law) involving a total of 5 years of formal University training and prescribed practical training, or (iv) Prescribed apprenticeship/articleship and pass examinations conducted by the concerned professional association (e.g. MBA/IAS/IFS). In selecting the individual professionals, experience gained by them in their respective fields will be taken note of.

b) Relevant experience

- Experience shall be related to professional qualification acquired by the person and be related to one or more of the expertise mentioned for the expert members. Such experience should be a minimum of 15 years.
- When the experience mentioned in the foregoing sub-paragraph interfaces with environmental issues, problems and their management, the requirement for the length of the experience can be reduced to a minimum of 10 years.

c) Absence of conflict of interest

For the deliberations of the EAC/SEAC to be independent and unbiased, all possibilities of potential conflict of interests have to be eliminated. Therefore, serving government officers; persons engaged in industry and their associations; persons associated with the formulation of development projects requiring environmental clearance, and persons associated with environmental activism shall not be considered for membership of SEIAA/ SEAC/ EAC.

iii. Age

Below 70 years for the members and below 72 years for the Chairperson of the SEIAA/SEAC/EAC. The applicability of the age is at the time of the Notification of the SEIAA/SEAC/EAC by the Central Government.

Summary regarding the eligibility criteria for Chairperson and Members of the EAC/SEAC is given in Table 5-4.

Stakeholders' Roles and Responsibilities

Table 5-4: EAC/SEAC: Eligibility Criteria for Chairperson / Members / Secretary

S. No.	Attribute		Requirement		
			Expert members	Secretary	Chairperson
1	Professional qualification as per the Notification		Compulsory	Compulsory	Compulsory
2	Experience (Fulfilling any one of a, b, c)	a	Professional Qualification + 15 years of experience in one of the expertise area mentioned in the Appendix VI	Professional Qualification + 15 years of experience in one of the expertise area mentioned in the Appendix VI	Professional Qualification + 15 years of experience in one of the expertise area mentioned in the Appendix VI
		b	Professional Qualification +PhD+10 years of experience in one of the expertise area mentioned in the Appendix VI	Professional Qualification +PhD+10 years of experience in one of the expertise area mentioned in the Appendix VI	Professional Qualification +PhD+10 years of experience in one of the expertise area mentioned in Appendix VI
		c	Professional Qualification +10 years of experience in one of the expertise area mentioned in the Appendix VI + 5 years interface with environmental issues, problems and their management	Professional Qualification +10 years of experience in one of the expertise area mentioned in the Appendix VI + 5 years interface with environmental issues, problems and their management	-----
3	Test of independence (conflict of interest) and minimum grade of the Secretary of the Committees		<p>Shall not be a serving government officer</p> <p>Shall not be a person engaged in industry and their associations</p> <p>Shall not be a person associated with environmental activism</p>	<p>In case of EAC, not less than a Director from the MoEF, Government of India</p> <p>In case of SEAC, not below the level of Director/Chief Engineer from the State Government (DoE)</p>	<p>Shall not be a serving government officer</p> <p>Shall not be a person engaged in industry and their associations</p> <p>Shall not be a person associated with environmental activism</p>
4	Age		Below 67 years at the time of Notification of the Committee	As per state Government Service Rules	Below 72 Years at the time of the Notification of the Committee
5	Membership in Central /State Expert Appraisal committee		Only one other than this nomination is permitted	Shall not be a member in other SEIAA/EAC/SEAC	Shall not be a member in any other SEIAA/EAC/SEAC
6	Tenure of earlier appointment (continuous)		Only one term before this in continuity is permitted	Not applicable	Only one term before this in continuity is permitted

Stakeholders' Roles and Responsibilities

S. No.	Attribute	Requirement		
		Expert members	Secretary	Chairperson
7	Eminent environmental expertise with understanding on environmental aspects and impacts	Desirable	Not applicable	Compulsory

Note:

1. A member after continuous membership in two terms (six years) shall not be considered for further continuation. His/her nomination may be reconsidered after a gap of one term (three years), if other criteria meet.

2. Chairperson/Member once notified may not be removed prior to the tenure of 3 years with out cause and proper enquiry. A member after continuous membership in two terms (6 years) shall not be considered for further continuation. The same profile may be considered for nomination after a gap of three years, i.e., one term, if other criteria are meeting.

E. Other conditions

- An expert member of one State/UT, can have at the most another State/UT Committee membership, but in no case more than two Committees at a given point of time.
- An expert member of a Committee shall not have membership continuously in the same committee for more than two terms, i.e. six years. They can be nominated after a gap of three years, i.e., one term. When a member of Committee has been associated with any development project, which comes for environmental clearance, he/she may not participate in the deliberations and the decisions in respect to that particular project
- At least four members shall be present in each meeting to fulfill the quorum
- If a member does not consecutively attend six meetings, without prior intimation to the Committee his/her membership may be terminated by the Notifying Authority. Prior information for absence due to academic pursuits, career development and national/state-endorsed programmes may be considered as genuine grounds for retention of membership.

ANNEXURE I
Environmental Guidelines For Control of Fugitive Emissions
from Cement Plants

ENVIRONMENTAL GUIDELINES FOR PREVENTION AND CONTROL OF FUGITIVE EMISSIONS FROM CEMENT PLANTS

For achieving effective prevention and control of potential fugitive emission sources in cement manufacturing plants, specific requirements along with guidelines have been evolved. In order to establish proper management practices, requirements such as Operation and Maintenance aspects, trained manpower and documents & records to be maintained are also prescribed. In addition, general guidelines are also evolved for the sources otherwise not specified.

1.1 Requirements for Prevention and control of fugitive emission for various Potential Sources

For the purpose of effective prevention and control of fugitive emissions, the cement industry is required to implement the following for the sections mentioned:

1. Unloading Section (Limestone, Coal & other relevant material)

Sr. No.	Control Measures to be Provided	Guidelines
1.	Enclosure should be provided for all unloading operations, except wet materials like gypsum	The enclosures for the unloading sides could be flexible curtain type material covering up to height of dumpers discharge from the roof.
2.	Water shall be sprayed on the material prior and during unloading	A dust suppression system should be provided to spray water. The amount of water sprayed should preferably be optimized by employing proper design of spray system. Suitable systems may be adopted to reduce the problems like choking, jamming of the moving parts.

2. Material Handling Section (Including Transfer Points)

Sr. No.	Control Measures to be Provided	Guidelines
1.	All transfer point locations should be fully enclosed.	The enclosures from all sides with the provision for access doors, which shall be kept, closed during operation. Spillages should be periodically removed.
2.	Airborne dust at all transfer operations / points should be controlled either by spraying water or by extracting to bag filter.	Either water spray system should be provided for suppressing the air borne dust or dry extraction cum bag filter with adequate extraction volume.

3.	Belt conveyors should preferably be closed.	This will avoid wind blowing of fines.
----	---	--

3. Coal Storage Section

Sr. No.	Control Measures to be Provided	Guidelines
1.	Coal yard / storage area should be clearly earmarked.	A board should be erected to display the area earmarked.
2.	The pathways in coal yard for vehicle movement should be paved.	Proper pathways with entry and exit point should be provided.
3.	Accumulated dust shall be removed / swept regularly and water the area after sweeping.	Any deposits of dust on the concrete roads should be cleaned regularly by sweeping machines.
4.	Coal other than coal stock pile should preferably be stored under covered shed.	Where ever blending activity is carried out by chaining in open ground, covered shed should be provided to reduce the fine coal dust getting airborne. The enclosure walls shall cover minimum three sides up to roof level.
5.	The coal stock pile should preferably be under covered shed for new plants.	The enclosure should be from three sides and roof so as to contain the airborne emissions.
6.	Instead of dust extraction cum bag filter system, If dust suppression measure is used, following additional control measures should be provided.	
a	Wetting before unloading.	Coal should be sufficiently moistened to suppress fines by spraying minimum quantity of water, if possible.
b	Spray water at crusher discharge and transfer points.	Water spray should also be applied at crusher discharge and transfer points.

4. Clinker Cooler Section

Sr. No.	Control Measures to be Provided	Guidelines
1.	Air borne fines extracted from clinker cooler shall be separated and sent to last possible destination directly, if possible.	The possibilities especially in new cement plant may be explored for the following: The unit may need to add on / install necessary provisions for separating fine particulates from the clinker cooler ESP collection. Fines separation may be achieved by passing collected dust through cyclone, the fines escaping cyclone to be separated, cyclone collection (coarse particles) could be

		recycled. The fines shall be recycled to the last possible destination (like clinker day silo) suitable or safely disposed.
--	--	---

5. Clinker Stock Piles Section

Sr. No.	Control Measures to be Provided	Guidelines
1.	In new cement plant, clinker should be stored preferably in silo.	Bag filter may be provided before venting out the gases.
2.	Clinker should be stored in closed enclosure covered from all sides and should have a venting arrangement along with a bag filter.	The enclosures should have a venting arrangement located at transfer point where clinker is dropped to the stockpile. The extraction / venting should be sufficient enough. Clinker stockpile access door should be covered by mechanical gate or by flexible rubber curtain. The access doors shall be kept closed at all possible times.
3.	The dust extracted and captured in bag filter should be avoided to feed back / recycled to the clinker stockpile, if possible.	Extracted dust should be captured in bag filter and the collected dust should be avoided to feed back to the clinker stockpile, if layout permits. It may be recycled at last possible destination i.e., cement mill section through suitable arrangement, if possible.
4.	Generally open storage of clinker should be avoided. Only in case of emergency clinker should be stored in open with following control measures.	
5.	Area for open storage of clinker should be clearly earmarked.	After earmarking the open storage area of clinker, a board should be erected to display the area earmarked.
6.	Provide cover on openly stored clinker.	During the period when the openly stored clinker is inactive, it should be covered fully by HDPE or tarpaulin type sheets to prevent wind blowing of fugitive dust.
7.	Provide windbreak walls or greenbelt on three sides of open stock piles	Install three sided enclosures, which extend to average height of the stockpile, where ever feasible.
8.	Provide partial enclosure for retrieving area.	Flexible type wind breaking enclosure should be provided covering the clinker retrieval area as wind barrier to prevent dust carry over by wind. The enclosure could be of lightweight material like moulded plastic material or similar, which could be dismantled / assembled and shifted from one place to other.
9.	The travel path of pay loaders should be paved and frequently	Travel areas path used by the front – end pay loader shall be paved with concrete. It should

	swept.	be regularly swept by high efficiency vacuum sweeper to minimize the material build – up.
10.	Provide loading of clinker by pay loaders into trucks / trailers be carried out in an enclosure vented to a bag filter.	The possibilities especially in new cement plant may be explored for the following: An enclosure fitted with bag filter could be located at the most central place adjacent to the clinker storage area. The pay loader moves to the fixed loading area from one end of the enclosure and the truck/trailer enters the enclosure from other end.

6. Storage of Limestone, Gypsum, Flyash and other additives:

Sr. No.	Control Measures to be Provided	Guidelines
1.	The storage should be done under covered shed.	The enclosure walls shall cover minimum two sides up to roof level.
2.	Dry fly ash shall be transported by closed tankers. In case of wet fly ash trucks may be used for transportation.	Flyash shall be pumped directly from the tankers to silos pneumatically in closed loop or mechanically such that fugitive emissions do not occur.
3.	Dry Fly ash shall be stored in silos only.	The silo vent be provided with a bag filter type system to vent out the air borne fines.
4.	Flyash in the dry form should be encouraged and in wet form should be discouraged. In case wet flyash is to be used, it may be stored in open temporarily for the purpose of drying with necessary wind break arrangement to avoid wind carryover of fly ash. The fly ash should be removed immediately after drying.	If possible, the dry flyash should be sent to closed silos. Otherwise, flyash should be transported through closed belt conveyors to avoid wind carryover of flyash.

7. Cement Packing Section:

Sr. No.	Control Measures to be Provided	Guidelines
1.	Provide dust extraction arrangement for packing machines.	The packing machines should be equipped with dust extraction arrangement such that the packing operation is performed under negative pressure. The dust may be captured in bag filters.
2.	Provide adequate ventilation	Adequate ventilation for the packing hall

	for the packing hall.	should be provided for venting out suspended particulate thereby ensuring dust free work environment.
3.	Spillage of cement on floor shall be minimized and cleared daily to prevent fugitive emissions.	The spilled cement from the packing machine should be collected properly and sent for recycling. The spilled cement on the shop floor should be swept by vacuum sweeping machines periodically. Proper engineering controls to prevent the fugitive emissions may include arrangements like providing guiding plate, scrapper brush for removing adhered dust on cement bag etc.
4.	Prevent emissions from the recycling screen by installing appropriate dust extraction system.	The vibratory screen provided for screening/recycling spilled cement should be provided with a dust extraction arrangement to prevent fugitive emission from that section.

8. Silo Section :

Sr. No.	Control Measures to be Provided	Guidelines
1.	The silo vent be provided with a bag filter type system to vent out the air borne fines.	The bag filter should be operated and maintained properly, especially the cleaning of bags to avoid pressurization of silos thereby causing fugitive emissions from leakages etc.

9. Roads:

Sr. No.	Control Measures to be Provided	Guidelines
1.	All roads on which vehicle movement of raw materials or products take place should be paved.	The paved roads should be maintained as paved at all times and necessary repairs to be done immediately after damages to the road if any.
2.	Limit the speed of vehicles.	Limit the speed of vehicle to 10 Km/h for heavy vehicles with in the plant premises to prevent the road dust emissions.
3.	Employ preventive measures to minimize dust build up on roads.	Preventive measures include covering of trucks and paving of access areas to unpaved areas.
4.	Carry out regular sweeping of roads to minimize emissions.	Mitigative controls include vacuum sweeping, water flushing.

1.2 Requirement of Maintaining Documentation and Records:

The industry shall maintain records to document the specific dust control actions taken and maintain such records for a period of not less than two years and make such records available to the regulatory authorities upon request. In addition documents of technical specifications of the control system and O&M guidelines should also be maintained. (Refer Appendix A1 for details of documents and records to be maintained)

1.3 Requirement of trained Manpower:

- The industry shall employ or contract a “dust control officer” who shall be available on site during working hours and should have authority to expeditiously employ sufficient dust mitigation measures to ensure control of fugitive emissions especially in abnormal circumstances. *A suitably qualified person could be designated to operate as dust control officer. But, he should be provided necessary training and should be aware of operational, maintenance aspects. He should be responsible for proper control of fugitive emissions. Environmental Officer may act as a Dust Control Officer.*
- Regular training should be given to the personnel operating and maintaining fugitive emissions control systems on the operational and maintenance aspects and record keeping responsibility.

1.4 Operation and Maintenance Requirement for all Dust Extraction cum Bag filter Systems:

- A “U”-tube manometer (of minimum 400 mm length) shall be fixed at all bag filters. It shall be connected with inlet and outlet side of the bag filter through flexible rubber tubes. Coloured water should be filled to zero level mark for proper visibility of the pressure drop across bag filter.
- The minimum dust extraction volume should be based on the guidelines for ventilating various sources as per industrial ventilation hand book guidelines
- Un-interrupted supply of dry compressed air at desired pressure should be always ensured for pulsejet cleaning type bag filter.
- The flow rate and static pressure at the bag filter inlet should be monitored at least quarterly and recorded to ensure appropriate functioning of the bag filter installed.
- A sampling platform, portable and access ladder shall be provided at the final stack to carry out stack monitoring (in main stacks). Final emission should not exceed the prescribed standard.
- In systems where water is also spread, it should be ensured that water does not get carried over/sucked to the bag filter. The details such as bag house

specifications, layout drawing, operation and maintenance guidelines are to be maintained.

- The details such as bag house specifications, layout drawing, operation and maintenance guidelines are to be maintained.

1.5 Operation and maintenance Requirements for all Dust Suppression Systems:

- Basic details/specifications of the dust suppression systems installed at various locations should be maintained. The information should contain the quantity of water sprayed in LPH, number of nozzles, type of nozzles, desired water pressure, details of suppliers of spares, pipeline diagram, system layout etc.
- A fine mesh micro filter should be installed for filtering suspended solids from water prior to pumping to the nozzles to prevent choking of nozzles thereby ensuring proper sprays.
- A pressure gauge and water flow meter shall be installed at major source for on-line measurements and a record be maintained for quantity of water sprayed.

1.6 SPM Concentration Standard for Assessing Effectiveness of Control Measures Adopted:

- The effectiveness of prevention cum control measures provided for controlling fugitive emissions from any source shall be said to be satisfactory, provided the SPM concentration, measured at 10 metre distance (from the enclosure wall housing the emission source or from the edge of the stockpiles/pavement area) in downwind direction shall not exceed 2000 microgram per cubic metre and 5000 microgram per cubic metre for coal yard /coal stock pile and rest other area respectively. These standards are for one year period and will be reviewed after one year. In cases where SPM concentrations exceed the prescribed limit, necessary corrective measures in terms of improving the controls shall be taken and action taken records of improvements carried out be maintained.
- The measurement shall be carried out by High Volume / Respirable type samplers as per standard method prescribed by CPCB/BIS, covering at least 4 hours duration (240 minutes) during normal working hours with normal production rate of the operation / source being monitored on quarterly basis.

1.7 General Guidelines (For areas not otherwise specified):

Apart from the specific guidelines provided above for some specific sections/areas, for all other fugitive dust emitting areas, following general guidelines would apply.

- The industry should prevent fugitive emission from all active operation and storage piles, such that the emissions are not visible in the atmosphere beyond the boundary line of the emission source.
- The Industry shall conduct active operations by utilizing the applicable best available control measures to minimize the fugitive dust emission from each fugitive dust source type within active operation.
- Except for Gypsum and Clinker, all storage piles should be kept in moist condition by spraying water at regular intervals for controlling fugitive emission, wherever possible
- The operation of the pay loaders shall be slow down whenever the average wind speed is high exceeding 50 km/h, which may cause fugitive emission.
- All storage silos shall be vented to bag filters, which should have proper bag cleaning arrangement so as to avoid choking of filter bags, thereby to avoid pressurization of silos.
- Regular inspection at a pre-determined frequency be carried out of all fugitive dust control system and records be maintained of such inspection and corrective action taken if any.

A 1: List of Documents & records to be maintained for fugitive dust control

Title of Record to be maintained	Frequency of Recording	Information to be recorded
Documents:		
List of Fugitive Emission Management Systems (FEMS) installed	To be up-dated once in a year	Location of FEMS, marked on process flow diagram, Identity Number, Type of FEMS, Year of installation, Operating Status
Technical Specifications of FEMS installed		
Specification of Dust suppression system	As and when installed/modified	Locations of controlling emissions, Identity Number, Supplier Name, Date of Commissioning, Pump HP, flow rate in LPM, Pressure in kg/cm ² , Nozzles type, numbers, LPM, O&M instruction from supplier.
Specification of Dust Extraction cum APCD	As and when installed/modified	Location of system installed, Identity Number, Name of system supplier, date of commissioning, flow rate in m ³ /hr, Time, flow m ³ /hr, static pressure mmWc, velocity m/sec, Current Drawn by ID fan motor, operation & maintenance instruction from supplier.
Capacities of Closed Storages	Annually	For coal, limestone, clinker, gypsum, cement, additives, flyash, Dimensions, bulk density, Tons
Capacities of Open Storages	Annually	For coal, limestone, clinker, gypsum, additives, flyash, Dimensions, bulk density, Tons
Records		
Replacement of Damaged filter bags	As and when replaced	Number of Bags replaced, Date, Bag filter Identification number
Measurement of flow rate static pressure at bag filter inlet	Once a month	Bag filter Number, Date of monitoring, Time, flow m ³ /hr, static pressure mmWc, velocity m/sec, Current Drawn by ID fan motor Name of the person
Stack Monitoring of bag filters stack, where ever monitoring is feasible	Quarterly	Bag filter Number, Date of monitoring, Time, Measured Data in m ³ /hr and mmWc, Dust concentration in mg/Nm ³

Operational Details of Dust Suppression System	Once in a month	Quantity of material handled, Quantity of water sprayed, number of operational nozzles, water pressure at filter inlet and outlet, details of damaged nozzles and replacements,
Road Sweeping record	Daily	Road location swept, date, running hours of sweeping machines
Quantity of coal in open storage, if any	Quarterly	Inventory of Existing storage, add on, retrieved on quarterly basis, Date
Quantity of clinker in open storage, if any	Quarterly	Inventory of Existing storage, add on, retrieved on quarterly basis, Date
Corrective actions taken for improving controls	As and when	Details of modifications carried out, level of reduction in SPM achieved

ANNEXURE II
A Compilation of Legal Instruments

REFERENCE TO EXISTING LEGAL INSTRUMENTS APPLICABLE TO CEMENT INDUSTRIES

Sl. No.	Legal Instrument (Type, Reference, Year)	Responsible Ministries or Bodies	Chemical Use Categories/Chemical By-products Covered	Objective of Legislation	Relevant Articles/Provisions
1	Air (Prevention and Control of Pollution) Act, 1981 amended 1987	Central Pollution Control Board and State Pollution Control Boards	Air pollutants from chemical industries	The prevention, control and abatement of air pollution	Section 2: Definitions Section 21: Consent from State Boards Section 22: Not to allow emissions exceeding prescribed limits Section 24: Power of Entry and Inspection Section 25: Power to Obtain Information Section 26: Power to Take Samples Section 37-43: Penalties and Procedures
2	Air (Prevention and Control of Pollution) (Union Territories) Rules, 1983	Central Pollution Control Board and State Pollution Control Boards	Air pollutants from chemical industries	The prevention, control and abatement of air pollution	Rule 2: Definitions Rule 9: Consent Applications
3	Water (Prevention and Control of Pollution) Act, 1974 amended 1988	Central Pollution Control Board and State Pollution Control Boards	Water Pollutants from water polluting industries	The prevention and control of water pollution and also maintaining or restoring the wholesomeness of water	Section 2: Definitions Section 20: Power to Obtain Information Section 21: Power to Take Samples Section 23: Power of Entry and Inspection Section 24: Prohibition on Disposal Section 25: Restriction on New Outlet and New Discharge Section 26: Provision regarding existing discharge of sewage or trade effluent Section 27: Refusal or withdrawal of consent by state boards Section 41-49: Penalties and Procedures

4	Water (Prevention and Control of Pollution) Rules, 1975	Central Pollution Control Board and State Pollution Control Boards	Water Pollutants from water polluting industries	The prevention and control of water pollution and also maintaining or restoring the wholesomeness of water	Rule 2: Definitions Rule 30: Power to take samples Rule 32: Consent Applications
5	The Environment (Protection) Act, 1986, amended 1991	Ministry of Environment & Forests, Central Pollution Control Board and State Pollution Control Boards	All types of environmental pollutants	Protection and Improvement of the Environment	Section 2: Definitions Section 7: Not to allow emission or discharge of environmental pollutants in excess of prescribed standards Section 8: Handling of Hazardous Substances Section 10: Power of Entry and Inspection Section 11: Power to take samples Section 15-19: Penalties and Procedures
6	Environmental (Protection) Rules, 1986 (Amendments in 1999, 2001, 2002, 2002, 2002, 2003, 2004)	Ministry of Environment & Forests, Central Pollution Control Board and State Pollution Control Boards	All types of environmental pollutants	Protection and Improvement of the Environment	Rule 2: Definitions Rule 3: Standards for emission or discharge of environmental pollutants Rule 5: Prohibition and restriction on the location of industries and the carrying on process and operations in different areas Rule 13: Prohibition and restriction on the handling of hazardous substances in different areas Rule 14: Submission of environmental statement

7	Hazardous Waste (Management and Handling) Rules, 1989 amended 2000 and 2003	MoEF, CPCB, SPCB, DGFT, Port Authority and Customs Authority	Hazardous Wastes generated from industries using hazardous chemicals	Management & Handling of hazardous wastes in line with the Basel convention	<p>Rule 2: Application</p> <p>Rule 3: Definitions</p> <p>Rule 4: Responsibility of the occupier and operator of a facility for handling of wastes</p> <p>Rule 4A: Duties of the occupier and operator of a facility</p> <p>Rule 4B: Duties of the authority</p> <p>Rule 5: Grant of authorization for handling hazardous wastes</p> <p>Rule 6: Power to suspend or cancel authorization</p> <p>Rule 7: Packaging, labeling and transport of hazardous wastes</p> <p>Rule 8: Disposal sites</p> <p>Rule 9: Record and returns</p> <p>Rule 10: Accident reporting and follow up</p> <p>Rule 11: Import and export of hazardous waste for dumping and disposal</p> <p>Rule 12: Import and export of hazardous waste for recycling and reuse</p> <p>Rule 13: Import of hazardous wastes</p> <p>Rule 14: Export of hazardous waste</p> <p>Rule 15: Illegal traffic</p> <p>Rule 16: Liability of the occupier, transporter and operator of a facility</p> <p>Rule 19: Procedure for registration and renewal of registration of recyclers and re-refiners</p> <p>Rule 20: Responsibility of waste generator</p>
---	---	--	--	---	---

8	Manufacture Storage and Import of Hazardous Chemicals Rules, 1989 amended 2000	Ministry of Environment & Forests, Chief Controller of Imports and Exports, CPCB, SPCB, Chief Inspector of Factories, Chief Inspector of Dock Safety, Chief Inspector of Mines, AERB, Chief Controller of Explosives, District Collector or District Emergency Authority, CEES under DRDO	Hazardous Chemicals - Toxic, Explosive, Flammable, Reactive	Regulate the manufacture, storage and import of Hazardous Chemicals	Rule 2: Definitions Rule 4: responsibility of the Occupier Rule 5: Notification of Major Accidents Rule 7-8: Approval and notification of site and updating Rule 10-11: Safety Reports and Safety Audit reports and updating Rule 13: Preparation of Onsite Emergency Plan Rule 14: Preparation of Offsite Emergency Plan Rule 15: Information to persons likely to get affected Rule 16: Proprietary Information Rule 17: Material Safety Data Sheets Rule 18: Import of Hazardous Chemicals
9	Chemical Accidents (Emergency Planning, Preparedness and Response) Rules, 1996	CCG, SCG, DCG, LCG and MAH Units	Hazardous Chemicals - Toxic, Explosive, Flammable, Reactive	Emergency Planning Preparedness and Response to chemical accidents	Rule 2: Definitions Rule 5: Functions of CCG Rule 7: Functions of SCG Rule 9: Functions of DCG Rule 10: Functions of LCG
10	EIA Notification, 2006	MoEF, SPCB	For all the identified developmental activities in the notification	Requirement of environmental clearance before establishment of or modernization / expansion of certain type of industries/ projects.	Requirements and procedure for seeking environmental clearance of projects

11	Batteries (Management and Handling) Rules, 2001.	SPCB, CPCB and MoEF	Lead Acid Batteries	To control the hazardous waste generation (lead waste) from used lead acid batteries	Rule 2: Application Rule 3: Definitions Rule 4: Responsibilities of manufacturer, importer, assembler and re-conditioner Rule 5: Registration of Importers Rule 7: Responsibilities of dealer Rule 8: Responsibilities of recycler Rule 9: Procedure for registration / renewal of registration of recyclers Rule 10: Responsibilities of consumer or bulk consumer Rule 11: Responsibilities of auctioneer Rule 14: Computerization of Records and Returns
12	Public Liability Insurance Act, 1991 amended 1992	Ministry of Environment & Forests, District Collector	Hazardous Substances	To provide immediate relief to persons affected by accident involving hazardous substances	Section 2: Definitions Section 3: Liability to give relief in certain cases on principle of no fault Section 4: Duty of owner to take out insurance policy Section 7A: Establishment of Environmental Relief Fund Section 14-18: Penalties and Offences
13	Public Liability Insurance Rules, 1991 amended 1993	Ministry of Environment & Forests, District Collector	Hazardous Substances	To provide immediate relief to persons affected by accident involving hazardous substances and also for Establishing an Environmental Relief fund	Rule 2: Definitions Rule 6: Establishment of administration of fund Rule 10: Extent of liability Rule 11: Contribution of the owner to environmental relief fund

14	Factories Act, 1948	Ministry of Labour, DGFASLI and Directorate of Industrial Safety and Health/Factories Inspectorate	Chemicals as specified in the Table	Control of workplace environment, and providing for good health and safety of workers	<p>Section 2: Interpretation</p> <p>Section 6: Approval, licensing and registration of factories</p> <p>Section 7A: General duties of the occupier</p> <p>Section 7B: General duties of manufacturers etc., as regards articles and substances for use in factories</p> <p>Section 12: Disposal of wastes and effluents</p> <p>Section 14: Dust and fume</p> <p>Section 36: Precautions against dangerous fumes, gases, etc.</p> <p>Section 37: Explosion or inflammable dust, gas, etc.</p> <p>Chapter IVA: Provisions relating to Hazardous processes</p> <p>Section 87: Dangerous operations</p> <p>Section 87A: Power to prohibit employment on account of serious hazard</p> <p>Section 88: Notice of certain accident</p> <p>Section 88A: Notice of certain dangerous occurrences</p> <p>Chapter X: Penalties and procedures</p>
15	The Petroleum Act, 1934	Ministry of Petroleum and Natural Gas	Petroleum (Class A, B and C - as defined in the rules)	Regulate the import, transport, storage, production, refining and blending of petroleum	<p>Section 2: Definitions</p> <p>Section 3: Import, transport and storage of petroleum</p> <p>Section 5: Production, refining and blending of petroleum</p> <p>Section 6: Receptacles of dangerous petroleum to show a warning</p> <p>Section 23-28 Penalties and Procedure</p>

16	The Petroleum Rules, 2002	Ministry of Petroleum and Natural Gas, Ministry of Shipping (for notification of authorized ports for import), Ministry of Environment & Forests or SPCB (for clearance of establishment of loading/unloading facilities at ports) Chief Controller of Explosives, district authority, Commissioner of Customs, Port Conservator, State Maritime Board (Import)	Petroleum (Class A, B and C - as defined in the rules)	Regulate the import, transport, storage, production, refining and blending of petroleum	Rule 2: Definition Chapter I part II: General Provision Chapter II: Importation of Petroleum Chapter III: Transport of Petroleum Chapter VII: Licenses
17	The Explosives Act, 1884	Ministry of Commerce and Industry (Department of Explosives)	Explosive substances as defined under the Act	To regulate the manufacture, possession, use, sale, transport, export and import of explosives with a view to prevent accidents	Section 4: Definition Section 6: Power for Central government to prohibit the manufacture, possession or importation of especially dangerous explosives Section 6B: Grant of Licenses

18	The Explosive Rules, 1983	Ministry of Commerce and Industry and Chief Controller of Explosives, port conservator, customs collector, railway administration	Explosive substances as defined under the Act	To regulate the manufacture, possession, use, sale, transport, export and import of explosives with a view to prevent accidents	Rule 2: Definition Chapter II: General Provisions Chapter III: Import and Export Chapter IV: Transport Chapter V: Manufacture of explosives Chapter VI: Possession sale and use Chapter VII: Licenses
19	The Gas Cylinder Rules, 2004	Ministry of Commerce and Industry and Chief Controller of Explosives, port conservator, customs collector, DGCA, DC, DM, Police (sub inspector to commissioner)	Gases (Toxic, non toxic and non flammable, non toxic and flammable, Dissolved Acetylene Gas, Non toxic and flammable liquefiable gas other than LPG, LPG	Regulate the import, storage, handling and transportation of gas cylinders with a view to prevent accidents	Rule 2: Definition Chapter II: General Provisions Chapter III: Importation of Cylinder Chapter IV: Transport of Cylinder Chapter VII: Filling and Possession
20	The Static and Mobile Pressure Vessels (Unfired) Rules, 1981	Ministry of Commerce and Industry and Chief Controller of Explosives, port conservator, customs collector, DGCA, DC, DM, Police (sub inspector to commissioner)	Gases (Toxic, non toxic and non flammable, non toxic and flammable, Dissolved Acetylene Gas, Non toxic and flammable liquefiable gas other than LPG, LPG	Regulate the import, manufacture, design, installation, transportation, handling, use and testing of mobile and static pressure vessels (unfired) with a view to prevent accidents	Rule 2: Definition Chapter III: Storage Chapter IV: Transport Chapter V: Licenses

21	The Motor Vehicle Act, 1988	Ministry of Shipping, Road Transport and Highways	Hazardous and Dangerous Goods	To consolidate and amend the law relating to motor vehicles	Section 2: Definition Chapter II: Licensing of drivers of motor vehicle Chapter VII: Construction equipment and maintenance of motor vehicles
22	The Central Motor Vehicle Rules, 1989	Ministry of Shipping, Road Transport and Highways	Hazardous and Dangerous Goods	To consolidate and amend the law relating to motor vehicles including to regulate the transportation of dangerous goods with a view to prevent loss of life or damage to the environment	Rule 2: Definition Rule 9: Educational qualification for driver's of goods carriages carrying dangerous or hazardous goods Rule 129: Transportation of goods of dangerous or hazardous nature to human life Rule 129A: Spark arrestors Rule 130: Manner of display of class labels Rule 131: Responsibility of the consignor for safe transport of dangerous or hazardous goods Rule 132: Responsibility of the transporter or owner of goods carriage Rule 133: Responsibility of the driver Rule 134: Emergency Information Panel Rule 135: Driver to be instructed Rule 136: Driver to report to the police station about accident Rule 137: Class labels
23	The Mines Act 1952	Ministry of Coal and Mines	Use of toxic and inflammable gases, dust or mixtures	Safety of the mine workers	Section 2: Definitions Chapter IV: Mining operations and management of mines Chapter V: Provisions as to health and safety Chapter IX: Penalties and procedure

24	The Custom Act, 1962	CBEC, Ministry of Finance	Hazardous Goods	To prevent entry of illegal hazardous goods or banned goods including hazardous or banned chemicals	Section 2: definitions Section 11: Power to Prohibit Importation or Exportation of Goods
25	The Merchant Shipping Act, 1958 amended in 2002 and 2003	Ministry of Shipping, Road Transport and Highways	All packaged cargo including Dangerous and hazardous goods as defined in the rules	For safe handling and transportation of cargo including dangerous goods to prevent accident	Section 3: Definitions Section 331: Carriage of Dangerous Goods
26	Merchant Shipping (carriage of Cargo) Rules 1995	Ministry of Shipping, Road Transport and Highways	All packaged cargo including Dangerous and hazardous goods as defined in the rules	For safe handling and transportation of cargo including dangerous goods to prevent accident	
27	The Indian Port Act, 1908	Ministry of Shipping, Road Transport and Highways	All Chemicals - handling and storage	For control of activities on ports including safety of shipping and conservation of ports	Section 2: Definitions Chapter IV: Rules for the safety of shipping and the conservation of ports Chapter VII: Provisions with respect to penalties
28	The Dock Workers, (Safety, Health and Welfare) Act, 1986	Ministry of Labour, DGFASLI and Directorate of Dock Safety	All Chemicals termed as dangerous goods	Safety of Dock workers including handling of dangerous goods	
29	The Dock Workers, (Safety, Health and Welfare) Rules, 1990	Ministry of Labour, DGFASLI and Directorate of Dock Safety	All Chemicals termed as dangerous goods	Safety of Dock workers including handling of dangerous goods	

30	Drug and Cosmetics Act, 1940	Ministry of Health and Family Welfare	To all types of drugs and cosmetics	To regulate the import, manufacture, distribution and sale of drugs	Section 2: Definitions Chapter III: Import of Drugs and Cosmetics Chapter IV: Manufacture, Sale and Distribution of Drugs and Cosmetics
----	------------------------------	---------------------------------------	-------------------------------------	---	---

ANNEXURE III
General Standards for Discharge of Environmental Pollutants

Table: Water Quality Standards

S. No.	Parameter	Standards			
		Inland Surface Water	Public Sewer	Land for Irrigation	Marine Coastal Areas
1.	2.	3.			
		(a)	(b)	(c)	(d)
1.	Colour and odour	See Note-1	—	See Note-1	See Note-1
2.	Suspended Solids, mg/l, Max	100	600	200	(a) For process waste water-100 (b) For cooling water effluent-10 per cent above total suspended matter of influent cooling water.
3.	Particle size of suspended solids	Shall pass 850 micron IS Sieve	—	—	(a) Floatable solids, Max 3 mm (b) Settleable solids Max 850 microns.
4.	Dissolved solids (inorganic), mg/a, mac	2100	2100	2100	—
5.	pH value	5.5 to 9.0	5.5 to 9.0	5.5 to 9.0	5.5 to 9.0
6.	Temperature °C, Max	Shall not exceed 40 in any section of the stream within 15 meters down stream from the effluent outlet	45 at the point of discharge	—	45 at the point of discharge
7.	Oil and grease, mg/l, max	10	20	10	20
8.	Total residual chlorine, mg/l, Max.	1.0	—	—	1.0
9.	Ammonical nitrogen (as N), mg/l, Max.	50	50	—	50
10.	Total Kjeldahl nitrogen (as N), mg/l, Max.	100	—	—	100
11.	Free Ammonia (as NH ₃), mg/l, Max.	5.0	—	—	5.0
12.	Biochemical Oxygen Demand (5 days at 20°C) Max.	30	350	100	100
13.	Chemical Oxygen Demand, mg/l, Max.	250	—	—	250
14.	Arsenic (as As), mg/l, Max.	0.2	0.2	0.2	0.2
15.	Mercury (as Hg), mg/l, Max.	0.01	0.01	—	0.01
16.	Lead (as Pb), mg/l, Max.	0.1	1.0	—	1.0
17.	Cadmium (as Cd), mg/l, Max.	2.0	1.0	—	2.0

18.	Hexavalent chromium (as Cr+6) mg/l, Max.	0.1	2.0	—	1.0
19.	Total chromium as (Cr), mg/l, Max.	2.0	2.0	—	2.0
20.	Copper (as Cu), mg/l, Max.	3.0	3.0	—	3.0
21.	Zinc (as Zn), mg/l, Max.	5.0	15	—	15
22.	Selenium (as Se), mg/l, Max.	0.05	0.05	—	0.05
23.	Nickel (as Ni), mg/l, Max.	3.0	3.0	—	5.0
24.	Boron (as B), mg/l, Max.	2.0	2.0	2.0	—
25.	Percent Sodium, Max.	—	60	60	—
26.	Residual sodium carbonate, mg/l, Max.	—	—	5.0	—
27.	Cyanide (as CN), mg/l, Max.	0.2	2.0	0.2	0.2
28.	Chloride (as Cl), mg/l, Max.	1000	1000	600	(a)
29.	Fluoride (as F), mg/l, Max.	2.0	15	—	15
30.	Dissolved Phosphates (as P), mg/l, Max.	5.0	—	—	—
31.	Sulphate (as SO ₄), mg/l, Max.	1000	1000	1000	—
32.	Sulphide (as S), mg/l, Max.	2.0	—	—	5.0
33.	Pesticides	Absent	Absent	Absent	Absent
34.	Phenolic compounds (as C ₆ H ₅ OH), mg/l, Max.	1.0	5.0	—	5.0
35.	Radioactive materials				
	(a) Alpha emitters MC/ml, Max.	10 ⁻⁷	10 ⁻⁷	10 ⁻⁸	10 ⁻⁷
	(b) Beta emitters uc/ml, Max.	10 ⁻⁶	10 ⁻⁶	10 ⁻⁷	10 ⁻⁶

Note :-

1. All efforts should be made to remove colour and unpleasant odour as far as practicable.
2. The standards mentioned in this notification shall apply to all the effluents discharged such as industrial mining and mineral processing activities municipal sewage etc.

Table: Noise Standards

Ambient air quality standards in respect of noise

Area Code	Category of Area	Limits in dB (A) Leq	
		Day Time	Night Time
(A)	Industrial area	75	70
(B)	Commercial area	65	55
(C)	Residential area	55	45
(D)	Silence zone	50	40

Note :

1. Day time is reckoned in between 6.00 AM and 9.00 PM
2. Night time is reckoned in between 9.00 PM and 6.00 AM
3. Silence zone is defined as areas upto 100 meters around such premises as hospitals, educational institutions and courts. The Silence zones are to be declared by the Competent Authority.
4. Use of vehicular horns, loudspeakers and bursting of crackers shall be banned in these zones.
5. Mixed categories of areas should be declared as one of the four above mentioned categories by the Competent Authority and the corresponding standards shall apply.

Standards/Guidelines for Control of Noise Pollution from Stationary Diesel Generator (DG) Sets

(A) Noise Standards for DG Sets (15-500 KVA)

The total sound power level, L_w , of a DG set should be less than, $94+10 \log_{10} (KVA)$, dB (A), at the manufacturing stage, where, KVA is the nominal power rating of a DG set.

This level should fall by 5 dB (A) every five years, till 2007, i.e. in 2002 and then in 2007.

(B) Mandatory acoustic enclosure/acoustic treatment of room for stationary DG sets (5 KVA and above)

Noise from the DG set should be controlled by providing an acoustic enclosure or by treating the room acoustically.

The acoustic enclosure/acoustic treatment of the room should be designed for minimum 25 dB(A) Insertion Loss or for meeting the ambient noise standards, whichever is on the higher side (if the actual ambient noise is on the higher side, it may not be possible to check the performance of the acoustic enclosure/acoustic treatment. Under such circumstances the performance may be checked for noise reduction upto actual ambient noise level, preferably, in the night time). The measurement for Insertion Loss may be done at different points at 0.5m from the acoustic enclosure/room, and then averaged.

The DG set should also be provide with proper exhaust muffler with Insertion Loss of minimum 25 dB(A).

(C) Guidelines for the manufacturers/users of DG sets (5 KVA and above)

1. The manufacturer should offer to the user a standard acoustic enclosure of 25 dB(A) Insertion Loss and also a suitable exhaust muffler with Insertion Loss of 25 dB(A).

2. The user should make efforts to bring down the noise levels due to the DG set, outside his premises, within the ambient noise requirements by proper siting and control measures.
3. The manufacturer should furnish noise power levels of the unlicensed DG sets as per standards prescribed under (A)
4. The total sound power level of a DG set, at the user's end, shall be within 2 dB(A) of the total sound power level of the DG set, at the manufacturing stage, as prescribed under (A).
5. Installation of a DG set must be strictly in compliance with the recommendation of the DG set manufacturer.
6. A proper routine and preventive maintenance procedure for the DG set should be set and followed in consultation with the DG set manufacturer which would help prevent noise levels of the DG set from deteriorating with use.

Order of the Lt. Governor of Delhi in respect of D.G. Sets (5th December, 2001)

In exercise of the powers conferred by section 5 of the Environment (Protection) Act, 1986, (29 of 1986), read with the Government of India, Ministry of Home Affairs notification S.O. 667 (E) bearing No. F.No. U-11030/J/91-VTL dated 10th September, 1992, the Lt. Governor of Government of National Capital of Delhi hereby directs to all owners/users of generators sets in the National Capital Territory of Delhi as follows :-

1. that generator sets above the capacity of 5 KVA shall not be operated in residential areas between the hours of 10.00 PM to 6.00 AM;
2. that the generator sets above the capacity of 5 KVA in all areas residential/commercial/industrial shall operate only with the mandatory acoustic enclosures and other standards prescribed in the Environment (Protection) Rules, 1986;
3. that mobile generator sets used in social gatherings and public functions shall be permitted only if they have installed mandatory acoustic enclosures and adhere to the prescribed standards for noise and emission as laid down in the Environment (Protection) Rules, 1986.

The contravention of the above directions shall make the offender liable for prosecution under section 15 of the said Act which stipulates punishment of imprisonment for a term which may extend to five years with fine which may extend to one lakh rupees, or with both, and in case the failure of contravention continues, with additional fine which may extend to five thousand rupees for every day during which such failure or contravention continues after the conviction for the first such failure or contravention and if still the failure or contravention continues beyond a period of one year after the date of contravention, the offender continues beyond a period of one year after the date of contravention, the offender shall be punishable with imprisonment for a term which may extend to seven years.

Order Dated: 21st June, 2002

In exercise of the powers conferred by section 5 of the Environment (Protection) Act, 1986 (29 of 1986) read with the Govt. of India, Ministry of Home Affairs notification S.O. 667(E) bearing No. U-11030/J/91-VTL dated the 10th September, 1992, the Lt. Governor Govt. of the National Capital Territory of Delhi hereby makes the following amendment/modification in his order dated the 5th December, 2001 regarding the operation of generator sets, namely:-

Amendments/modifications

In the above said order, for clause(1), the following shall be substituted, namely:-

“(1) that the generator sets above 5KVA shall not be operated in residential areas between the hours from 10.00 p.m. to 6.00 a.m. except generator sets of Group Housing Societies and Multi-storey residential apartments”.

DIESEL GENERATOR SETS: STACK HEIGHT

The minimum height of stack to be provided with each generator set can be worked out using the following formula:

$$H = h + 0.2 \times \text{OKVA}$$

H = Total height of stack in metre

h = Height of the building in metres where the generator set is installed

KVA = Total generator capacity of the set in KVA

Based on the above formula the minimum stack height to be provided with different range of generator sets may be categorized as follows:

For Generator Sets	Total Height of stack in metre
50 KVA	Ht. of the building + 1.5 metre
50-100 KVA	Ht. of the building + 2.0 metre
100- 150 KVA	Ht. of the building + 2.5 metre
150-200 KVA	Ht. of the building + 3.0 metre
200-250 KVA	Ht. of the building + 3.5 metre
250-300 KVA	Ht. of the building + 3.5 metre

Similarly for higher KVA ratings a stack height can be worked out using the above formula

Source: Evolved By CPCB

[Emission Regulations Part IV: COINDS/26/1986-87]

ANNEXURE IV
Form 1 (Application Form for Obtaining EIA Clearance)

FORM 1

(I) BASIC INFORMATION

S. No.	Item	Details
1.	Name of the project/s	
2.	S.No. in the schedule	
3.	Proposed capacity/area/length/tonnage to be handled/command area/lease area/number of wells to be drilled	
4.	New/Expansion/Modernization	
5.	Existing Capacity/Area etc.	
6.	Category of Project i.e., 'A' or 'B'	
7.	Does it attract the general condition? If yes, please specify.	
8.	Does it attract the specific condition? If yes, Please specify.	
9.	Location	
	Plot/Survey/Khasra No.	
	Village	
	Tehsil	
	District	
	State	
10.	Name of the applicant	
11.	Registered Address	
12.	Address for correspondence:	
	Name	
	Designation (Owner/Partner/CEO)	
	Address	
	Pin Code	
	E-mail	
	Telephone No.	
	Fax No.	
13.	Details of alternative Sites examined, if any location of these sites should be shown on a toposheet.	Village-District-State 1. 2. 3.

S. No.	Item	Details
14.	Interlined Projects	
15.	Whether separate application of interlined project has been submitted	
16.	If yes, date of submission	
17.	If no, reason	
18.	Whether the proposal involves approval/clearance under: The Forest (Conservation) Act, 1980 The Wildlife (Protection) Act, 1972 The C.R.Z. Notification, 1991	
19.	Forest land involved (hectares)	
20.	Whether there is any litigation pending against the project and/or land in which the project is propose to be set up Name of the Court Case No. Orders/directions of the Court, if any and its relevance with the proposed project.	

(II) ACTIVITY

1. Construction, operation or decommissioning of the Project involving actions, which will cause physical changes in the locality (topography, land use, changes in water bodies, etc.)

S.No.	Information/Checklist confirmation	Yes/No	Details thereof (with approximate quantities /rates, wherever possible) with source of information data
1.1	Permanent or temporary change in land use, land cover or topography including increase in intensity of land use (with respect to local land use plan)		
1.2	Clearance of existing land, vegetation and buildings?		
1.3	Creation of new land uses?		
1.4	Pre-construction investigations e.g. bore houses, soil testing?		
1.5	Construction works?		

S.No.	Information/Checklist confirmation	Yes/No	Details thereof (with approximate quantities /rates, wherever possible) with source of information data
1.6	Demolition works?		
1.7	Temporary sites used for construction works or housing of construction workers?		
1.8	Above ground buildings, structures or earthworks including linear structures, cut and fill or excavations		
1.9	Underground works including mining or tunneling?		
1.10	Reclamation works?		
1.11	Dredging?		
1.12	Offshore structures?		
1.13	Production and manufacturing processes?		
1.14	Facilities for storage of goods or materials?		
1.15	Facilities for treatment or disposal of solid waste or liquid effluents?		
1.16	Facilities for long term housing of operational workers?		
1.17	New road, rail or sea traffic during construction or operation?		
1.18	New road, rail, air waterborne or other transport infrastructure including new or altered routes and stations, ports, airports etc?		
1.19	Closure or diversion of existing transport routes or infrastructure leading to changes in traffic movements?		
1.20	New or diverted transmission lines or pipelines?		
1.21	Impoundment, damming, culverting, realignment or other changes to the hydrology of watercourses or aquifers?		
1.22	Stream crossings?		
1.23	Abstraction or transfers of water form ground or surface waters?		
1.24	Changes in water bodies or the land surface affecting drainage or run-off?		
1.25	Transport of personnel or materials for construction, operation or decommissioning?		

S.No.	Information/Checklist confirmation	Yes/No	Details thereof (with approximate quantities /rates, wherever possible) with source of information data
1.26	Long-term dismantling or decommissioning or restoration works?		
1.27	Ongoing activity during decommissioning which could have an impact on the environment?		
1.28	Influx of people to an area in either temporarily or permanently?		
1.29	Introduction of alien species?		
1.30	Loss of native species or genetic diversity?		
1.31	Any other actions?		

2. Use of Natural resources for construction or operation of the Project (such as land, water, materials or energy, especially any resources which are non-renewable or in short supply):

S.No.	Information/checklist confirmation	Yes/No	Details thereof (with approximate quantities /rates, wherever possible) with source of information data
2.1	Land especially undeveloped or agricultural land (ha)		
2.2	Water (expected source & competing users) unit: KLD		
2.3	Minerals (MT)		
2.4	Construction material – stone, aggregates, sand / soil (expected source – MT)		
2.5	Forests and timber (source – MT)		
2.6	Energy including electricity and fuels (source, competing users) Unit: fuel (MT), energy (MW)		
2.7	Any other natural resources (use appropriate standard units)		

3. Use, storage, transport, handling or production of substances or materials, which could be harmful to human health or the environment or raise concerns about actual or perceived risks to human health.

S.No	Information/Checklist confirmation	Yes/No	Details thereof (with approximate quantities/rates, wherever possible) with source of information data
3.1	Use of substances or materials, which are hazardous (as per MSIHC rules) to human health or the environment (flora, fauna, and water supplies)		
3.2	Changes in occurrence of disease or affect disease vectors (e.g. insect or water borne diseases)		
3.3	Affect the welfare of people e.g. by changing living conditions?		
3.4	Vulnerable groups of people who could be affected by the project e.g. hospital patients, children, the elderly etc.,		
3.5	Any other causes		

4. Production of solid wastes during construction or operation or decommissioning (MT/month)

S.No.	Information/Checklist confirmation	Yes/No	Details thereof (with approximate quantities/rates, wherever possible) with source of information data
4.1	Spoil, overburden or mine wastes		
4.2	Municipal waste (domestic and or commercial wastes)		
4.3	Hazardous wastes (as per Hazardous Waste Management Rules)		
4.4	Other industrial process wastes		
4.5	Surplus product		
4.6	Sewage sludge or other sludge from effluent treatment		
4.7	Construction or demolition wastes		
4.8	Redundant machinery or equipment		

S.No.	Information/Checklist confirmation	Yes/No	Details thereof (with approximate quantities/rates, wherever possible) with source of information data
4.9	Contaminated soils or other materials		
4.10	Agricultural wastes		
4.11	Other solid wastes		

5. Release of pollutants or any hazardous, toxic or noxious substances to air (kg/hr)

S.No	Information/Checklist confirmation	Yes/No	Details thereof (with approximate quantities/rates, wherever possible) with source of information data
5.1	Emissions from combustion of fossil fuels from stationary or mobile sources		
5.2	Emissions from production processes		
5.3	Emissions from materials handling including storage or transport		
5.4	Emissions from construction activities including plant and equipment		
5.5	Dust or odours from handling of materials including construction materials, sewage and waste		
5.6	Emissions from incineration of waste		
5.7	Emissions from burning of waste in open air (e.g. slash materials, construction debris)		
5.8	Emissions from any other sources		

6. Generation of Noise and Vibration, and Emissions of Light and Heat:

S.No.	Information/Checklist confirmation	Yes/No	Details thereof (with approximate quantities/rates, wherever possible) with source of information data with source of information data
6.1	From operation of equipment e.g. engines, ventilation plant, crushers		
6.2	From industrial or similar processes		
6.3	From construction or demolition		
6.4	From blasting or piling		
6.5	From construction or operational traffic		
6.6	From lighting or cooling systems		
6.7	From any other sources		

7. Risks of contamination of land or water from releases of pollutants into the ground or into sewers, surface waters, groundwater, coastal waters or the sea:

S.No.	Information/Checklist confirmation	Yes/No	Details thereof (with approximate quantities/rates, wherever possible) with source of information data
7.1	From handling, storage, use or spillage of hazardous materials		
7.2	From discharge of sewage or other effluents to water or the land (expected mode and place of discharge)		
7.3	By deposition of pollutants emitted to air into the land or into water		
7.4	From any other sources		
7.5	Is there a risk of long term build up of pollutants in the environment from these sources?		

8. Risk of accidents during construction or operation of the Project, which could affect human health or the environment

S.No	Information/Checklist confirmation	Yes/No	Details thereof (with approximate quantities/rates, wherever possible) with source of information data
8.1	From explosions, spillages, fires etc from storage, handling, use or production of hazardous substances		
8.2	From any other causes		
8.3	Could the project be affected by natural disasters causing environmental damage (e.g. floods, earthquakes, landslides, cloudburst etc)?		

9. Factors which should be considered (such as consequential development) which could lead to environmental effects or the potential for cumulative impacts with other existing or planned activities in the locality

S. No.	Information/Checklist confirmation	Yes/No	Details thereof (with approximate quantities/rates, wherever possible) with source of information data
9.1	Lead to development of supporting facilities, ancillary development or development stimulated by the project which could have impact on the environment e.g.: <ul style="list-style-type: none"> ▪ Supporting infrastructure (roads, power supply, waste or waste water treatment, etc.) ▪ housing development ▪ extractive industries ▪ supply industries ▪ other 		
9.2	Lead to after-use of the site, which could have an impact on the environment		
9.3	Set a precedent for later developments		
9.4	Have cumulative effects due to proximity to other existing or planned projects with similar effects		

(III) ENVIRONMENTAL SENSITIVITY

S.No.	Areas	Name/ Identity	Aerial distance (within 15 km.) Proposed project location boundary
1	Areas protected under international conventions, national or local legislation for their ecological, landscape, cultural or other related value		
2	Areas which are important or sensitive for ecological reasons - Wetlands, watercourses or other water bodies, coastal zone, biospheres, mountains, forests		
3	Areas used by protected, important or sensitive species of flora or fauna for breeding, nesting, foraging, resting, over wintering, migration		
4	Inland, coastal, marine or underground waters		
5	State, National boundaries		
6	Routes or facilities used by the public for access to recreation or other tourist, pilgrim areas		
7	Defence installations		
8	Densely populated or built-up area		
9	Areas occupied by sensitive man-made land uses (<i>hospitals, schools, places of worship, community facilities</i>)		
10	Areas containing important, high quality or scarce resources (<i>ground water resources, surface resources, forestry, agriculture, fisheries, tourism, minerals</i>)		
11	Areas already subjected to pollution or environmental damage. (<i>those where existing legal environmental standards are exceeded</i>)		
12	Areas susceptible to natural hazard which could cause the project to present environmental problems (<i>earthquakes, subsidence, landslides, erosion, flooding or extreme or adverse climatic conditions</i>)		

(IV) PROPOSED TERMS OF REFERENCE FOR EIA STUDIES

“I hereby given undertaking that the data and information given in the application and enclosure are true to the best of my knowledge and belief and I am aware that if any part of the data and information submitted is found to be false or misleading at any stage, the project will be rejected and clearance give, if any to the project will be revoked at our risk and cost.

Date: _____

Place: _____

Signature of the applicant
With Name and Full Address
(Project Proponent / Authorized Signatory)

NOTE:

1. The projects involving clearance under Coastal Regulation Zone Notification, 1991 shall submit with the application a C.R.Z. map duly demarcated by one of the authorized, agencies, showing the project activities, w.r.t. C.R.Z. and the recommendations of the State Coastal Zone Management Authority. Simultaneous action shall also be taken to obtain the requisite clearance under the provisions of the C.R.Z. Notification, 1991 for the activities to be located in the CRZ.
2. The projects to be located within 10km of the National Parks, Sanctuaries, Biosphere Reserves, Migratory Corridors of Wild Animals, the project proponent shall submit the map duly authenticated by Chief Wildlife Warden showing these features vis-à-vis the project location and the recommendations or comments of the Chief Wildlife Warden thereon.”

ANNEXURE V
Critically Polluted Industrial Areas and Clusters/Potential Impact
Zone

**Table 1: Details of Critically Polluted Industrial Areas and Clusters / Potential Impact Zone
(Ref: Office Memorandum No. J-11013/5/2010-IA.II(I) Dated 13.1.2010)**

S. No.	Critically Polluted Industrial Area and CEPI	Industrial Clusters/ Potential Impact Zones
1.	Ankeshwar (Gujarat) CEPI-88.50(Ac_Wc_Lc)	<ul style="list-style-type: none"> ▪ GIDC Ankeshwar and GIDC, Panoli
2	Vapi (Gujarat) CEPI-88.09(Ac_Wc_Lc)	<ul style="list-style-type: none"> ▪ GIDC Vapi
3	Ghaziabad (Uttar Pradesh) CEPI-87.37(Ac_Wc_Lc)	<p>Sub-cluster A</p> <ul style="list-style-type: none"> ▪ Mohan nagar industrial area ▪ Rajinder nagar industrial area ▪ Sahibabad industrial area <p>Sub-cluster B</p> <ul style="list-style-type: none"> ▪ Pandav nagar industrial area ▪ Kavi nagar industrial area ▪ Bulandshahar road industrial area ▪ Amrit nagar ▪ Aryanagar industrial area <p>Sub-cluster C</p> <ul style="list-style-type: none"> ▪ Merrut road industrial are <p>Sub-cluster D</p> <ul style="list-style-type: none"> ▪ Loni industrial area ▪ Loni Road industrial area ▪ Roop nagar industrial area <p>Sub-cluster E</p> <ul style="list-style-type: none"> ▪ Hapur Road industrial area ▪ Dasna ▪ Philkura <p>Sub-cluster F (Other scattered industrial areas)</p> <ul style="list-style-type: none"> ▪ South side of GT road ▪ Kavi Nagar ▪ Tronica city ▪ Anand Nagar ▪ Jindal Nagar ▪ Prakash Nagar ▪ Rural industrial estate
4	Chandrapur (Maharashtra) CEPI-83.88 (Ac_Wc_Lc)	<ul style="list-style-type: none"> ▪ Chandrapur (MIDC Chandrapur, Tadali, Ghuggus, Ballapur)
5	Kobra (Chhatisgarh) CEPI-83.00 (Ac_Ws_Lc)	<ul style="list-style-type: none"> ▪ Industrial areas and their townships of NTPC, BALCO, CSEB (East) & CSEB (West) ▪ Korba town
6	Bhiwadi (Rajasthan) CEPI-82.91 (Ac_Wc_Ls)	<ul style="list-style-type: none"> ▪ RIICO industrial areas Phase I to IV ▪ Bhiwadi town ▪ Other surrounding industrial areas: Chopanki, Rampura Mundana, Khuskhera Phase I to III
7	Angul Talcer(Orissa) CEPI-82.09 (Ac_Wc_Lc)	<ul style="list-style-type: none"> ▪ MCL Coal mining area, Augul – Talcer region ▪ Industrial area (60 km x 45 km) <p>Following blocks of Augul district:</p> <ul style="list-style-type: none"> ▪ Kohina block ▪ Talcher block

		<ul style="list-style-type: none"> ▪ Angul block ▪ Chhendipada block ▪ Banarpal block ▪ Odapada block of Dhenkamal district
8	Vellore (North Arcot) (Tamil Nadu) CEPI-81.79 (Ac_Wc_Lc)	<ul style="list-style-type: none"> ▪ Ranipet, SIPCOT industrial complex
9	Singrauli (Uttar Pradesh) CEPI-81.73 (Ac_Wc_Ls)	<p>Sonebhadra (UP)</p> <ul style="list-style-type: none"> ▪ Dala-Tola ▪ Obra ▪ Renukoot ▪ Anpara ▪ Renusagar ▪ Kakri ▪ Dudhichuwa ▪ Bina ▪ Khadia ▪ Shakti nagar ▪ Rihand nagar ▪ Bijpur <p>Sigrauli (Madhya Pradesh)</p> <p>Vindhyachal nagar and Jaynat, Nigahi, Dudhichua, Amlohri & Jhingurdah townships</p>
10	Ludhiana (Punjab) CEPI-81.66 (Ac_Wc_Ls)	<p>Ludhiana municipal limits covering industrial clusters:</p> <ul style="list-style-type: none"> ▪ Focal point along with NH-I- Total eight phase ▪ Industrial area-B- from sherpur chowk to Gill road & Gill road to Miller Kotla road (left side of road) ▪ Mixed industrial area – right side of Gill road ▪ Industrial area –C (near Juglana village) ▪ Industrial area A & extension: area between old GT road and Ludhiana bypass road ▪ Industrial estate: near Dholwal chowk ▪ Mixes industrial area (MIA) Miller gunj ▪ MIA – bypass road ▪ Bahdur industrial area ▪ Tejpur industrial complex
11	Nazafgarh drain basin, Delhi CEPI-79.54 (As_Wc_Lc)	<ul style="list-style-type: none"> ▪ Industrial areas: Anand Parvat, Naraina, Okhla and Wazirpur
12	Noida (Uttar Pradesh) CEPI-78.90 (Ac_Wc_Lc)	<p>Territorial Jurisdiction of:</p> <ul style="list-style-type: none"> ▪ Noida Phase-1 ▪ Noida Phase-2 ▪ Noida Phase-3 ▪ Surajpur industrial area ▪ Greater Noida industrial area ▪ Village- Chhaparaula
13	Dhanbad (Jharkhand) CEPI-78.63 (Ac_Ws_Lc)	<p>Four blocks of Dhanbad district:</p> <ul style="list-style-type: none"> ▪ Sadar (Dhanbad Municipality) ▪ Jharia (Jharia Municipality, Sindri industrial area) ▪ Govindpur (Govindpur industrial estate) ▪ Nirsa
14	Dombivalli (Maharashtra) CEPI-78.41 (Ac_Wc_Ls)	<ul style="list-style-type: none"> ▪ MIDC Phase- I, Phase- II

15	Kanpur (Uttar Pradesh) CEPI-78.09 (Ac_Wc_Ls)	Industrial areas: <ul style="list-style-type: none"> ▪ Dada nagar ▪ Panki ▪ Fazalganj ▪ Vijay nagar ▪ Jajmau
16	Cuddalore (Tamil Nadu) CEPI-77.45 (As_Wc_Lc)	<ul style="list-style-type: none"> ▪ SIPCOT industrial complex, Phase I & II
17	Aurangabad (Maharashtra) CEPI-77.44 (Ac_Wc_Ls)	<ul style="list-style-type: none"> ▪ MIDC Chikhalthana, MIDC Waluj, MIDC Shendra, and Paithan road industrial area
18	Faridabad (Haryana) CEPI-77.07 (Ac_Ws_Lc)	<ul style="list-style-type: none"> ▪ Sector 27-A, B, C, D ▪ DLF phase- 1, sector 31,32 ▪ DLF phase- 2, sector 35 ▪ Sector 4, 6, 24, 27, 31, 59 ▪ Industrial area Hatin ▪ Industrial model township
19	Agra (Uttar Pradesh) CEPI-76.48 (As_Wc_Ls)	<ul style="list-style-type: none"> ▪ Nunihai industrial estate, Rambag nagar, UPSIDC industrial area, and Runukata industrial area
20	Manali (Tamil Nadu) CEPI-76.32 (Ac_Ws_Ls)	<ul style="list-style-type: none"> ▪ Manali industrial area
21	Haldia (West Bengal) CEPI-75.43 (As_Wc_Ls)	<ul style="list-style-type: none"> ▪ 5 km wide strip (17.4 x 5.0 km) of industrial area on the southern side of the confluence point of Rivers Hugli and Rupnarayan, covering ▪ Haldia municipal area & Sutahata block – I and II
22	Ahmedabad (Gujarat) CEPI-75.28 (Ac_Ws_Ls)	<ul style="list-style-type: none"> ▪ GIDC Odhav ▪ GIDC Naroda
23	Jodhpur (Rajasthan) CEPI-75.19 (As_Wc_Ls)	<ul style="list-style-type: none"> ▪ Industrial areas including Basni areas (phase-I & II), industrial estate, light & heavy industrial areas, industrial areas behind new power house, Mandore, Bornada, Sangariya and village Tanwada & Salawas. ▪ Jodhpur city
24	Greater Cochin (Kerala) CEPI-75.08 (As_Wc_Ls)	<ul style="list-style-type: none"> ▪ Eloor-Edayar industrial belt, ▪ Ambala Mogal industrial areas
25	Mandi Gobind Garh (Punjab) CEPI-75.08 (Ac_Ws_Lc)	<ul style="list-style-type: none"> ▪ Mandi Govindgarh municipal limit and khanna area
26	Howrah (West Bengal) CEPI-74.84 (As_Ws_Lc)	<ul style="list-style-type: none"> ▪ Liluah-Bamangachhi region, Howrah ▪ Jalan industrial complex-1, Howrah
27	Vatva (Gujarat) CEPI-74.77 (Ac_Wc_Ls)	<ul style="list-style-type: none"> ▪ GIDC Vatva, Narol industrial area (Villages Piplaj, Shahwadi, Narol)
28	Ib Valley (Orissa) CEPI-74.00 (Ac_Ws_Ls)	<ul style="list-style-type: none"> ▪ Ib Valley of Jharsuguda (Industrial and mining area)
29	Varansi-Mirzapur (Uttar Pradesh) CEPI-73.79 (As_Wc_Ls)	<ul style="list-style-type: none"> ▪ Industrial estate, Mirzapur ▪ Chunar ▪ Industrial estate, Chandpur, Varansi ▪ UPSIC, industrial estate, Phoolpur ▪ Industrial area, Ramnagar, Chandauli
30	Navi Mumbai (Maharashtra) CEPI-73.77 (Ac_Ws_Ls)	<ul style="list-style-type: none"> ▪ TTC industrial area, MIDC, Navi Mumbai (including Bocks-D, C, EL, A, R, General, Kalva)

31	Pali (Rajasthan) CEPI-73.73 (As_Wc_Ls)	<ul style="list-style-type: none"> ▪ Existing industrial areas: Mandia road, Puniyata road, Sumerpur ▪ Pali town
32	Mangalore (Karnataka) CEPI-73.68 (Ac_Ws_Ls)	<ul style="list-style-type: none"> ▪ Baikampady industrial area
33	Jharsuguda (Orissa) CEPI-73.34 (Ac_Ws_Ls)	<ul style="list-style-type: none"> ▪ Ib valley of Jharsuguda (Industrial and mining area)
34	Coimbatore (Tamil Nadu) CEPI-72.38 (Ac_Ws_Ln)	<ul style="list-style-type: none"> ▪ SIDCO, Kurichi industrial Clusters
35	Bhadravati (Karnataka) CEPI-72.33 (Ac_Ws_Ln)	<ul style="list-style-type: none"> ▪ KSSIDC Industrial area, Mysore paper mill & VISL township complex
36	Tarapur (Maharashtra) CEPI-72.01 (Ac_Ws_Ls)	<ul style="list-style-type: none"> ▪ MIDC Tarapur
37	Panipat (Haryana) CEPI-71.91 (As_Ws_Ls)	<ul style="list-style-type: none"> ▪ Panipat municipal limit and its industrial clusters
38	Indore (Madhya Pradesh) CEPI-71.26 (As_Ws_Ls)	<p>Following 09 industrial area:</p> <ul style="list-style-type: none"> ▪ Sanwer road ▪ Shivaji nagar ▪ Pologround ▪ Laxmibai nagar ▪ Scheme no.71 ▪ Navlakha ▪ Pipliya ▪ Palda ▪ Rau <p>Indore city</p> <p>Other surrounding industrial areas: Manglia, Rajoda, Asrawad, Tejpur Gadwadi</p>
39	Bhavnagar (Gujarat) CEPI-70.99 (As_Ws_Ls)	<ul style="list-style-type: none"> ▪ GIDI Chitra, Bhavnagar
40	Vishakhapatnam (Andhra Pradesh) CEPI-70.82 (As_Ws_Ls)	<ul style="list-style-type: none"> ▪ Bowl area (the area between Yarada hill range in the south to Simhachalam hill range in the north and sea on the east and the present NH-5 in the west direction)
41	Junagarh (Gujarat) CEPI-70.82 (As_Ws_Ls)	<p>Industrial areas:</p> <ul style="list-style-type: none"> ▪ Sabalpur ▪ Jay Bhavani ▪ Jay Bhuvneshwari ▪ GIDC Junagarh (I&II)
42	Asansole (West Bengal) CEPI-70.20 (As_Ws_Ls)	<ul style="list-style-type: none"> ▪ Bumpur area surrounding IISCO
43	Patancheru - Bollaram (Andhra Pradesh) CEPI-70.07 (As_Ws_Ls)	<p>Industrial area:</p> <ul style="list-style-type: none"> ▪ Patancheru ▪ Bollaram

Note:

Names of identified industrial clusters/potential impact zones are approximate location based on rapid survey and assessment and may alter partially subject to the detailed field study and monitoring. Detailed mapping will be made available showing spatial boundaries of the identified industrial clusters including zone of influence/ buffer zone, after in depth field study.

ANNEXURE VI
Pre-Feasibility Report: Points for Possible Coverage

Table 1: Points for Possible Coverage in Pre-feasibility Report

S. No.	Contents	Points of Coverage in Pre-feasibility Report
I.	Executive summary	<ul style="list-style-type: none"> ▪ Details on prima facie idea of the project.
II.	Project Details	
	Need/Justification of the Project	<ul style="list-style-type: none"> ▪ Current demand scenario of the product ▪ Alternatives to meet the demand ▪ Post project scenario on residual demand
	Capacity of Cement Plant	<ul style="list-style-type: none"> ▪ Production capacity of the industry ▪ Sustainability of raw material supply and quality ▪ Optimization of plant capacity
	Process technology	<ul style="list-style-type: none"> ▪ Analysis of all available/advanced technologies, etc. ▪ Analysis of various possible configurations for each technology or a combination of these technologies from available manufactures ▪ Broad specifications for the cement industry (s) including but not limited to: <ul style="list-style-type: none"> - Plant outputs and process flow diagrams for each alternative - Electrical equipment, I&C equipment, DCS equipment with redundancy - Balance of plant equipment - General plant layout
	Resources/raw materials	<ul style="list-style-type: none"> ▪ Details on raw material, by products/coproducts ▪ Water <ul style="list-style-type: none"> - Water requirement for process, utilities, domestic, gardening etc. - Source of construction water and potable water - Source of circulating/consumptive water - Quality of raw water, treated water - Water budget calculations and effluent generation - Approved water allocation quota (drinking, irrigation and industrial use) and surplus availability - Feasible ways of bringing water to site indicating constraints if any. - Lean season water availability and allocation source in case main source not perennial. ▪ Manpower ▪ Infrastructure ▪ Electrical power ▪ Construction material like sand, brick, stone chips, borrow earth etc.
	Rejects (Pollution potential)	<ul style="list-style-type: none"> ▪ Air emissions ▪ Water pollution ▪ Solid / hazardous waste ▪ Noise ▪ Odour
	Technical profile	<ul style="list-style-type: none"> ▪ Construction details <ul style="list-style-type: none"> - Estimated duration - Number of construction workers including migrating workers - Construction equipment - Vehicular traffic - Source, mode of transportation and storage of construction

		<ul style="list-style-type: none"> material ▪ Traffic that would arise during different phases of the project and transportation mechanism to handle such traffic ▪ New facilities needed ▪ Technical parameters of the plant & equipments to be used ▪ Product storage and associated transportation system ▪ Product demand & supply position data on regional basis
	Project schedule	<ul style="list-style-type: none"> ▪ Outline project implementation and procurement arrangement including contract packaging ▪ Project implementation schedule showing various activities
	Future prospects	<ul style="list-style-type: none"> ▪ Ascertain the costs and benefits of the proposed project for project life ▪ Technical and logistic constraints/ requirements of project sustainability
III.	Selection of site based on least possible impacts	
i.	Choice of site selection	
	Major techno-economic feasibility considerations	<ul style="list-style-type: none"> ▪ Land availability & its development ▪ Product demand around the selected site ▪ Access to site for transportation of equipments/construction machinery, material, <i>etc.</i> ▪ Raw material availability and its transportation ▪ Water availability and consumptive use ▪ Product transportation ▪ Infrastructure availability at selected site ▪ Inter-state issue, if any
	Incompatible landuse and ecologically sensitive attributes with respect to identified suitable sites	<ul style="list-style-type: none"> ▪ If any incompatible land-use attributes fall within the study area, the following details has to be provided: <ul style="list-style-type: none"> - Public water supply areas from rivers/surface water bodies, from groundwater - Scenic areas/tourism areas/hill resorts - Religious places, pilgrim centers that attract over 10 lakh pilgrims a year - Protected tribal settlements (notified tribal areas where industrial activity is not permitted); CRZ - Monuments of national significance, World Heritage Sites - Cyclone, Tsunami prone areas (based on last 25 years); - Airport areas - Any other feature as specified by the State or local government and other features as locally applicable, including prime agricultural lands, pastures, migratory corridors, <i>etc.</i> ▪ If ecologically sensitive attributes fall within the study area, please give details. Ecologically sensitive attributes include <ul style="list-style-type: none"> - National parks - Wild life sanctuaries Game reserve - Tiger reserve/elephant reserve/turtle nesting ground - Breeding grounds - Core zone of biosphere reserve - Habitat for migratory birds - Mangrove area - Tropical forests - Important lakes - Endangered species of flora and fauna, <i>etc.</i>
	Social aspects	<ul style="list-style-type: none"> ▪ Corporate responsibilities ▪ Employments and infrastructure added in the vicinity of the plant ▪ Status of land availability, current and post project land use

		<ul style="list-style-type: none"> ▪ variation ▪ Social sensitivity and likely project affected people
ii.	Details of selected site	
	Land details	<ul style="list-style-type: none"> ▪ Land requirement and availability ▪ Land ownership details such as Government, private, tribal, non-tribal, etc. ▪ Total area of the project/site ▪ Prevailing land cost details
	Location	<ul style="list-style-type: none"> ▪ Geographical details - Longitude & latitude, village, taluka, district, state ▪ Approach to site – roads, railways and airports ▪ Distance from nearest residential and industrial areas ▪ Distance from nearest water bodies such as river, canal, dam, etc ▪ Distance from ecologically sensitive areas ▪ In case of flood prone areas, HFL of the site ▪ In case of seismic areas, seismic zone, active faults, occurrence on earthquakes, etc. ▪ Proximity from infrastructural facilities
	Physical characteristics	<ul style="list-style-type: none"> ▪ Demography ▪ Meteorological data ▪ Landuse pattern such as agricultural, barren, forest, <i>etc.</i> and details thereof ▪ Topography of the area ▪ Drainage patterns ▪ Soil condition and soil investigation results ▪ Ground profile and levels
IV.	Anticipated impacts based on project operations on receiving environment	<ul style="list-style-type: none"> ▪ Population ▪ Flora and fauna ▪ Water ▪ Soil ▪ Air ▪ Climate ▪ Landscape, <i>etc.</i>
V.	Proposed broad mitigation measures which could effectively be internalized as project components to have environmental and social acceptance of the proposed site	<ul style="list-style-type: none"> ▪ Preventive measures ▪ Source control measures ▪ Mitigation measures at the receiving environment, <i>etc.</i>
VI.	An indication of any difficulties (technical deficiencies or lack of know-how) encountered by the developer in compiling the required information.	

The above listing is not exhaustive. Thus the proponent may provide additional necessary information, felt appropriate, to include in the pre-feasibility study report in support of selecting the site for the proposed developmental activities. The Concerned EAC/SEAC during scrutiny, may specifically ask for any additional information/data required to substantiate the requirement to prescribe the ToR for EIA studies. However, it is to make clear that all the required further information by EAC/SEAC may be mentioned in one single letter, within the prescribed time.

ANNEXURE VII
Types of Monitoring and Network Design Considerations

TYPES OF MONITORING AND NETWORK DESIGN CONSIDERATIONS

A. Types of Monitoring

Monitoring refers to the collection of data using a series of repetitive measurements of environmental parameters (or, more generally, to a process of systematic observation). The environmental quality monitoring programme design will be dependent upon the monitoring objectives specified for the selected area of interest. The main types of EIA monitoring activities are:

- Baseline monitoring is the measurement of environmental parameters during the pre-project period for the purpose of determining the range of variation of the system and establishing reference points against which changes can be measured. This leads to the assessment of the possible (additional available) assimilative capacity of the environmental components in pre-project period w.r.t. the standard or target level.
- Effects monitoring is the measurement of environmental parameters during project construction and implementation to detect changes which are attributable to the project to provide the necessary information to:
 - verify the accuracy of EIA predictions; and
 - determine the effectiveness of measures to mitigate adverse effects of projects on the environment.
 - Feedback from environmental effect monitoring programs may be used to improve the predictive capability of EIAs and also determine whether more or less stringent mitigation measures are needed
- Compliance monitoring is the periodic sampling or continuous measurement of environmental parameters to ensure that regulatory requirements and standards are being met.

Compliance and effects monitoring occurs during the project construction, operation, and abandonment stages. The resources and institutional set-up should be available for the monitoring at these stages. All large-scale construction projects will require some construction stage monitoring. To control the environmental hazards of construction as specified in the EIA, a monitoring program should be established to ensure that each mitigation measure is effectively implemented. There are numerous potential areas for monitoring during operations.

The scope of monitoring topics discussed in this chapter is limited to Baseline and Effects monitoring. In addition, this chapter will also discuss the Compliance monitoring during the construction phase. Post-project monitoring requirements are discussed in the EMP.

Before any field monitoring tasks are undertaken there are many institutional, scientific, and fiscal issues that must be addressed in the implementation of an environmental monitoring program. Careful consideration of these issues in the design and planning stages will help avoid many of the pitfalls associated with environmental monitoring programs. Although these issues are important but the discussions here are confined to the monitoring network design component.

B. Network Design

Analysis of Significant Environmental Issues

At the outset of planning for an environmental monitoring network, the EIA manager may not know exactly what should be monitored, when monitoring should begin, where it should monitor, which techniques should be employed, and who should take responsibility for its conduct. Because there are usually a number of objective decisions associated with network design to be

made, it is important to start with an analysis of environmental issues. The scoping phase of an EIA is designed to identify and focus on the major issues. Scoping should provide a valuable source of information on the concerns that need to be addressed by the monitoring network design. These are project specific as well as specific to the environmental setting of the location where the project is proposed to be located.

Hence, the network designs are associated with questions like:

- What are the expected outputs of the monitoring activity?
- Which problems do we need to address to? *etc.*

Defining the output will influence the design of the network and optimize the resources used for monitoring. It will also ensure that the network is specially designed to optimize the information on the problems at hand.

What to Monitor?

The question of what to monitor is associated with the identification of VECs.

VECs are generally defined as environmental attributes or components of the environment that are valued by society as identified during the scoping stage of the project. They are determined on the basis of perceived public concerns. For example, changes to water quality and quantity could have implications on fish by affecting habitat, food supply, oxygen, and contaminant uptake. Similarly, employment and business, and economies are both VECs that serve as pathways.

The choice of VECs is also related to the perceived significant impact of the project implementation on important environmental components. In general, the significance or importance of environmental components is judged based on:

- legal protection provided (for example, rare and endangered species)
- political or public concerns (for example, resource use conflicts and sustainable development)
- scientific judgment (for example, ecological importance); or
- commercial or economic importance

However, in addition to their economic, social, political or ecological significance, the chosen VEC should also have unambiguous operational ease, be accessible to prediction and measurement; and be susceptible to hazard. Once the VECs are defined, the VECs may be directly measured (for example, extent of habitat for an endangered species). In cases where it is impossible or impractical to directly measure the VECs, the chosen measurement endpoints or environmental indicators must correspond to, or be predictive of assessment endpoints.

The chosen environmental indicators must be: 1) measurable; 2) appropriate to the scale of disturbance/ contamination; 3) appropriate to the impact mechanism; 4) appropriate and proportional to temporal dynamics; 5) diagnostic; and 6) standardized; as well as have: 1) a low natural variability; 2) a broad applicability; and 3) an existing data series.

Where, How and How Many Times to Monitor?

These are the other components of Monitoring Network Design. These questions are best answered based on local field conditions, capacity and resources available, prevailing legal and regulatory priorities, *etc.* For this screening or reconnaissance Surveys of the study area also necessary. This may also include some simple inexpensive measurements and assimilative/dispersion modeling. The data will give some information on the prevailing special and temporal variations, and the general background air pollution in the area. The number of monitoring stations and the indicators to be measured at each station in the final permanent network may then be decided upon based on the results of the screening study as well as on the

knowledge of the sources of the proposed development and prevailing local environmental/meteorological conditions. The best possible definition of the air pollution problem, together with the analysis of the resources: personnel, budget and equipment available, represent the basis for the decision on the following questions:

- What spatial density (number) of sampling stations is required? How many samples are needed and during what period (sampling (averaging) time and frequency)?
- Where should the stations be located?
- What kind of equipment should be used?
- What additional background information is needed?
 - meteorology
 - topography
 - population density
 - emission sources and emission rates
 - effects and impacts
- How will the data be made available/communicated?

C. Site Selection

This normally means that for designing a monitoring programme in an (study) area which might have an impact, several monitoring stations are needed for characterizing the baseline conditions of the impacted area. When considering the location of individual samplers, it is essential that the data collected are representative for the location and type of area without the undue influence from the immediate surroundings. In any measurement point in the study area the total ambient concentration is the representative of:

- natural background concentration
- regional background
- impact of existing large regional sources such as Industrial emissions

To obtain the information about the importance of these different contributions it is therefore necessary to locate monitoring stations so that they are representative for different impacts. In addition to the ambient pollution data, one would often need other data governing the variations such as meteorological data for air pollution, to identify and quantify the sources contributing to the measurements. When considering the location of individual samplers, it is essential that the data collected are representative for the location and type of area without undue influence from the immediate surroundings.

ANNEXURE VIII
Guidance for Assessment of Baseline Components and Attributes

GUIDANCE FOR ASSESSMENT OF BASELINE COMPONENTS AND ATTRIBUTES*

Attributes	Sampling		Measurement Method	Remarks
	Network	Frequency		
A. Air				
<ul style="list-style-type: none"> ▪ Meteorological ▪ Wind speed ▪ Wind direction ▪ Dry bulb temperature ▪ Wet bulb temperature ▪ Relative humidity ▪ Rainfall ▪ Solar radiation ▪ Cloud cover 	<p>Minimum 1 site in the project impact area requirements</p> <p>Other additional site(s) are require depending upon the model applied or site sensitivities</p>	<p>Min: 1 hrly observations from continuous records</p>	<p>Mechanical / automatic weather station</p> <p>Rain gauge</p> <p>As per IMD</p> <p>As per IMD</p>	<p>IS 5182 Part 1-20 Sit-specific primary data is essential</p> <p>Secondary data from IMD, New Delhi for the nearest IMD station</p>
<p>Pollutants</p> <ul style="list-style-type: none"> ▪ SPM ▪ RPM ▪ SO2 ▪ NO2 ▪ CO ▪ H2S* ▪ NH*3 ▪ HC* ▪ Fluoride* ▪ Pb* ▪ VOC-PAH* ▪ Mercury* <p>(parameters to be proposed by the proponent, in draft ToR, which will be reviewed and approved by EAC/SEAC)</p>	<p>10 to 15 locations in the project impact area</p>	<p>24 hrly twice a week</p> <p>8 hrly twice a week</p> <p>24 hrly twice a week</p>	<ul style="list-style-type: none"> ▪ Gravimetric (High – Volume) ▪ Gravimetric (High – Volume with Cyclone) ▪ EPA Modified West & Gaeke method ▪ Arsenite Modified Jacob & Hochheiser ▪ NDIR technique ▪ Methylene-blue ▪ Nessler’s Method ▪ Infra Red analyzer ▪ Specific lon meter 	<p>Monitoring Network</p> <p>Minimum 2 locations in upwind side, more sites in downwind side / impact zone</p> <p>All the sensitive receptors need to be covered</p> <p>Measurement Methods</p> <p>As per CPCB standards for NAQM, 1994</p>

Attributes	Sampling		Measurement Method	Remarks
	Network	Frequency		
B. Noise				
Hourly equivalent noise levels	Same as for Air Pollution along with others Identified in study area	At least one day continuous in each season on a working and non-working day	Instrument : Sensitive Noise level meter (preferably recording type)	Min: IS: 4954- 1968 as adopted by CPCB
Hourly equivalent noise levels	Inplant (1.5 m from machinery or high emission processes)	Same as above for day and night	Instrument : Noise level meter	CPCB / OSHA
Hourly equivalent noise levels	Highways (within 500 meters from the road edge)	Same as above for day and night	Instrument : Noise level meter	CPCB / IS : 4954-1968
Peak particle velocity	150- 200m from blast site	Based on hourly observations	PPV meter	
C. Land Environment				
<ul style="list-style-type: none"> ▪ Soil ▪ Particle size distribution ▪ Texture ▪ pH ▪ Electrical conductivity ▪ Cation exchange capacity ▪ Alkali metals ▪ Sodium Absorption Ratio (SAR) ▪ Permeability ▪ Porosity 	One surface sample from each landfill and/or hazardous waste site (if applicable) and prime villages, (soil samples be collected as per BIS specifications) in the study area	Season-wise	Collected and analyzed as per soil analysis reference book, M.I.Jackson and soil analysis reference book by C.A. Black	The purpose of impact assessment on soil (land environment) is to assess the significant impacts due to leaching of wastes or accidental releases and contaminating
Land Use/Landscape				
<ul style="list-style-type: none"> ▪ Location code 	At least 20 points along	Drainage once in the	<ul style="list-style-type: none"> ▪ Global positioning 	Drainage within the plant

Attributes	Sampling		Measurement Method	Remarks
	Network	Frequency		
<ul style="list-style-type: none"> ▪ Total project area ▪ Topography ▪ Drainage (natural) ▪ Cultivated, forest plantations, water bodies, roads and settlements 	with plant boundary and general major land use categories in the study area. `	study period and land use categories from secondary data (local maps) and satellite imageries	<ul style="list-style-type: none"> ▪ system ▪ Topo-sheets ▪ Satellite Imageries (1:25,000) ▪ Satellite Imageries (1:25,000) 	<p>area and surrounding is very important for storm water impacts.</p> <p>From land use maps sensitive receptors (forests, parks, mangroves <i>etc.</i>) can be identified</p>
D. Solid Waste				
<p>Quantities</p> <ul style="list-style-type: none"> ▪ Based on waste generated from per unit production ▪ Per capita contribution ▪ Collection, transport and disposal system ▪ Process Waste ▪ Quality (oily, chemical, biological) 	For green field unites it is based on secondary data base of earlier plants.	Process wise or activity wise for respective raw material used. Domestic waste depends upon the season also	<p>Guidelines</p> <p>IS 9569 : 1980</p> <p>IS 10447 : 1983</p> <p>IS 12625 : 1989</p> <p>IS 12647 : 1989</p> <p>IS 12662 (PTI) 1989</p>	
<ul style="list-style-type: none"> ▪ General segregation into biological/organic/inert/hazardous ▪ Loss on heating ▪ pH ▪ Electrical Conductivity ▪ Calorific value, metals <i>etc.</i> 	Grab and Composite samples	Process wise or activity wise for respective raw material used. Domestic waste depends upon the season also	<p>Analysis</p> <p>IS 9334 : 1979</p> <p>IS 9235 : 1979</p> <p>IS 10158 : 1982</p>	
<p>Quality</p> <ul style="list-style-type: none"> ▪ Permeability And porosity ▪ Moisture pH 	Grab and Composite samples. Recyclable components have to	Process wise or activity wise for respective raw	<p>Analysis</p> <p>IS 9334 : 1979</p>	Impacts of hazardous waste should be performed critically

Attributes	Sampling		Measurement Method	Remarks
	Network	Frequency		
<ul style="list-style-type: none"> ▪ Electrical conductivity ▪ Loss on ignition ▪ Phosphorous ▪ Total nitrogen ▪ Cation exchange capacity ▪ Particle size distribution ▪ Heavy metal ▪ Ansonia ▪ Flouride 	analyzed for the recycling requirements	material used.	IS 9235 : 1979 IS 10158 : 1982	depending on the waste characteristics and place of discharge. For land disposal the guidelines should be followed and impacts of accidental releases should be assessed
E. Biological Environment (aquatic)				
<ul style="list-style-type: none"> ▪ Primary productivity ▪ Aquatic weeds ▪ Enumeration of phytoplankton, zooplankton and benthos ▪ Fisheries ▪ Diversity indices ▪ Trophic levels ▪ Rare and endangered species ▪ Sanctuaries / closed areas / Coastal regulation zone (CRZ) ▪ Terrestrial ▪ Vegetation – species, list, economic importance, forest produce, medicinal value ▪ Importance value index (IVI) of trees 	<p>Considering probable impact, sampling points and number of samples to be decided on established guidelines on ecological studies based on site eco-environment setting within 10/25 km radius from the proposed site</p> <p>Samples to collect from upstream and downstream of discharge point, nearby tributaries at down stream, and also from dug wells close to</p>	Season changes are very important	Standards techniques (APHA et. Al. 1995, Rau and Wooten 1980) to be followed for sampling and measurement	<p>Seasonal sampling for aquatic biota</p> <p>One season for terrestrial biota, in addition to vegetation studies during monsoon season</p> <p>Preliminary assessment</p> <p>Microscopic analysis of plankton and meiobenthos, studies of macrofauna, aquatic vegetation and application of indices, viz. Shannon, similarity, dominance IVI <i>etc.</i></p> <p>Point quarter plot-less method (random</p>

Attributes	Sampling		Measurement Method	Remarks
	Network	Frequency		
<ul style="list-style-type: none"> ▪ Wild animals 	activity site			sampling) for terrestrial vegetation survey.
Avifauna <ul style="list-style-type: none"> ▪ Rare and endangered species ▪ Sanctuaries / National park / Biosphere reserve 	For forest studies, chronic as well as short-term impacts should be analyzed warranting data on micro climate conditions			Secondary data to collect from Government offices, NGOs, published literature Plankton net Sediment dredge Depth sampler Microscope Field binocular
F. Socio-economic				
<ul style="list-style-type: none"> ▪ Demographic structure ▪ Infrastructure resource base ▪ Economic resource base ▪ Health status: Morbidity pattern ▪ Cultural and aesthetic attributes 	Socio-economic survey is based on proportionate, stratified and random sampling method	Different impacts occurs during construction and operational phases of the project	Primary data collection through R&R surveys (if require) or community survey are based on personal interviews and questionnaire	Secondary data from census records, statistical hard books, toposheets, health records and relevant official records available with Govt. agencies

* Project Specific concerned parameters needs to be identified by the project proponent and shall be incorporated in the draft ToR, to be submitted to the Authority for the consideration and approval by the EAC/SEAC.

ANNEXURE IX
Sources of Secondary Data

Annexure VIIA: Potential Sources of Data For EIA

Information	Source
Air Environment	
1. Meteorology- Temperature, Rainfall, Humidity, Inversion, Seasonal Wind rose pattern (16 point compass scale), cloud cover, wind speed, wind direction, stability, mixing depth	<ul style="list-style-type: none"> ⊗ Indian Meteorology Department, Pune
2. Ambient Air Quality- 24 hourly concentration of SPM, RPM, SO ₂ , NO _x , CO	<ul style="list-style-type: none"> ⊗ Central Pollution Control Board (CPCB), ⊗ State Pollution Control Board (SPCB), ⊗ Municipal Corporations ⊗ Ministry of Environment and Forests (MoEF) ⊗ State Department of Environment (DoEN)
Water Environment	
3. Surface water- water sources, water flow (lean season), water quality, water usage, Downstream water users Command area development plan Catchment treatment plan	<ul style="list-style-type: none"> ⊗ Central Water Commission (CWC), ⊗ Central Pollution Control Board (CPCB), ⊗ State Pollution Control Board (SPCB), Central Water and Power Research Institute (CWPRS), Pune ⊗ State Irrigation Department ⊗ Hydel Power generation organizations such as NHPC, State SEBs
4. Ground Water- groundwater recharge rate/withdrawal rate, ground water potential groundwater levels (pre monsoon, post monsoon), ground water quality, changes observed in quality and quantity of ground water in last 15 years	<ul style="list-style-type: none"> ⊗ Central Ground Water Board (CGWB) ⊗ Central Ground Water Authority (CGWA) ⊗ State Ground Water Board (SGWB) ⊗ National Water Development Authority (NWDA)
5. Coastal waters- water quality, tide and current data, bathymetry	<ul style="list-style-type: none"> ⊗ Department of Ocean Development, New Delhi ⊗ State Maritime Boards ⊗ Naval Hydrographer's Office, Dehradun ⊗ Port Authorities ⊗ National Institute of Oceanography (NIO), Goa
Biological Environment	
6. Description of Biological Environment- inventory of flora and fauna in 7 km radius, endemic species, endangered species, Aquatic Fauna, Forest land, forest type and density of vegetation, biosphere, national parks, wild life sanctuaries, tiger reserve, elephant reserve, turtle nesting ground, core zone of biosphere reserve, habitat of migratory birds, routes of migratory birds	<ul style="list-style-type: none"> ⊗ District Gazetteers ⊗ National Remote Sensing Agency (NRSA), Hyderabad ⊗ Forest Survey of India, Dehradun ⊗ Wildlife Institute of India ⊗ World Wildlife Fund ⊗ Zoological Survey of India ⊗ Botanical Survey of India ⊗ Bombay Natural History Society, (BNHS), Mumbai ⊗ State Forest Departments ⊗ State Fisheries Department ⊗ Ministry of Environment and Forests ⊗ State Agriculture Departments ⊗ State Agriculture Universities
Land Environment	
7. Geographical Information-Latitude, Longitude, Elevation (above MSL)	<ul style="list-style-type: none"> ⊗ Toposheets of Survey of India, Pune ⊗ National Remote Sensing Agency (NRSA), Hyderabad ⊗ Space Application Centre (SAC), Ahmedabad

Information	Source
8. Nature of Terrain, topography map indicating contours (1:2500 scale)	<ul style="list-style-type: none"> ⊗ Survey of India Toposheets ⊗ National Remote Sensing Agency (NRSA), Hyderabad ⊗ State Remote Sensing Centre, ⊗ Space Application Centre (SAC), Ahmedabad
9. Hydrogeology- Hydrogeological report (in case of ground water is used/area is drought prone/wastewater is likely to discharged on land) Geomorphological analysis (topography and drainage pattern) Geological analysis (Geological Formations/Disturbances- geological and structural maps, geomorphological contour maps, structural features, including lineaments, fractures, faults and joints) Hydrogeological analysis (disposition of permeable formations, surface-ground water links, hydraulic parameter determination etc) Analysis of the natural soil and water to assess pollutant absorption capacity	<ul style="list-style-type: none"> ⊗ NRSA, Hyderabad ⊗ Survey of India Toposheets ⊗ Geological Survey of India ⊗ State Geology Departments ⊗ State Irrigation Department ⊗ Department of Wasteland Development, Ministry of Rural Areas ⊗ National Water Development Authority (NWDA)
10. Nature of Soil, permeability, erodibility classification of the land	<ul style="list-style-type: none"> ⊗ Agriculture Universities ⊗ State Agriculture Department ⊗ Indian Council for Agriculture Research ⊗ State Soil Conservation Departments ⊗ National Bureau of Soil Survey and Landuse Planning ⊗ Central Arid Zone Research Institute (CAZRI), Jodhpur
11. Landuse in the project area and 10 km radius of the periphery of the project	<ul style="list-style-type: none"> ⊗ Survey of India- Toposheets ⊗ All India Soil and Landuse Survey; Delhi ⊗ National Remote Sensing Agency (NRSA), Hyderabad ⊗ Town and County Planning Organisation ⊗ State Urban Planning Department ⊗ Regional Planning Authorities (existing and proposed plans) ⊗ Village Revenue Map- District Collectorate ⊗ Directorate of Economics and Statistics-State Government ⊗ Space Application Centre, Ahmedabad
12. Coastal Regulation Zones- CRZMP, CRZ classification, Demarcation of HTL and LTL*	<ul style="list-style-type: none"> ⊗ Urban Development Department ⊗ State Department of Environment ⊗ State Pollution Control Board ⊗ Space Application Centre* ⊗ Centre for Earth Sciences Studies, Thiruvanthapuram* ⊗ Institute of Remote Sensing, Anna University Chennai* ⊗ Naval Hydrographer's Office, Dehradun* ⊗ National Institute of Oceanography, Goa* ⊗ National Institute of Ocean Technology, Chennai ⊗ Centre for Earth Science Studies

* Agencies authorized for approval of demarcation of HTL and LTL

Information	Source
Social	
13. Socioeconomic - population, number of houses and present occupation pattern within 7 km from the periphery of the project	<ul style="list-style-type: none"> ⊗ Census Department ⊗ District Gazetteers- State Government ⊗ District Statistics- District Collectorate ⊗ International Institute of Population Sciences, Mumbai (limited data) ⊗ Central Statistical Organisation
14. Monuments and heritage sites	<ul style="list-style-type: none"> District Gazetteer Archeological Survey of India, INTACH District Collectorate Central and State Tourism Department State Tribal and Social Welfare Department
Natural Disasters	
15. Seismic data (Mining Projects)- zone no, no of earthquakes and scale, impacts on life, property existing mines	<ul style="list-style-type: none"> ⊗ Indian Meteorology Department, Pune ⊗ Geological Survey of India
16. Landslide prone zone, geomorphological conditions, degree of susceptibility to mass movement, major landslide history (frequency of occurrence/decade), area affected, population affected	<ul style="list-style-type: none"> ⊗ Space Application Centre
17. Flood/cyclone/droughts- frequency of occurrence per decade, area affected, population affected	<ul style="list-style-type: none"> ⊗ Natural Disaster Management Division in Department of Agriculture and Cooperation ⊗ Indian Meteorological Department
Industrial	
18. Industrial Estates/Clusters, Growth Centres	<ul style="list-style-type: none"> ⊗ State Industrial Corporation ⊗ Industrial Associations ⊗ State Pollution Control Boards ⊗ Confederation Indian Industries (CII) ⊗ FICCI
19. Physical and Chemical properties of raw material and chemicals (Industrial projects); fuel quality	<ul style="list-style-type: none"> ⊗ Material and Safety Data Sheets ⊗ ENVIS database of Industrial Toxicological Research Centre, Lucknow ⊗ Indian Institute Petroleum
20. Occupational Health and Industrial Hygiene-major occupational health and safety hazards, health and safety requirements, accident histories	<ul style="list-style-type: none"> ⊗ Central Labour Institute, Mumbai ⊗ Directorate of Industrial Safety ⊗ ENVIS Database of Industrial Toxicological Research Centre, Lucknow ⊗ National Institute of Occupational Health, Ahmedabad
21. Pollutant release inventories (Existing pollution sources in area within 10 km radius)	<ul style="list-style-type: none"> ⊗ Project proponents which have received EC and have commenced operations
22. Water requirement (process, cooling water, DM water, Dust suppression, drinking, green belt, fire service)	<ul style="list-style-type: none"> ⊗ EIA Reports ⊗ National and International Benchmarks

Annexure VIIB: Summary of Available Data with Potential Data Sources for EIA

Agency	Information Available
1. Archaeological Survey of India Department of Culture Government of India Janpath, New Delhi - 110011 Asi@del3.vsnl.net.in	<ul style="list-style-type: none"> ⊙ Inventory of monuments and sites of national importance- Listing and documentation of monuments according to world heritage, pre historic, proto historic and secular, religious places and forts
2. Botanical Survey Of India P-8, Brabourne Road Calcutta 700001 Tel#033 2424922 Fax#033 2429330 Email: envis@cal2.vsnl.net.in . RO - Coimbatore, Pune, Jodhpur, Dehradun, Allahabad, Gantok, Itanagar, Port Blair	<ul style="list-style-type: none"> ⊙ Photodiversity documentation of flora at National, State and District level and flora of protected areas, hotspots, fragile ecosystems, sacred groves etc ⊙ Identification of threatened species including endemics, their mapping, population studies ⊙ Database related to medicinal plants, rare and threatened plant species ⊙ Red data book of Indian plants (Vol 1,2, and 3) ⊙ Manual for roadside and avenue plantation in India
3. Bureau of Indian Standards Manak Bhawan, 9 Bahadur Shah Zafar Marg, New Delhi 110 002 Tel#3230131, 3233375, 3239402 (10 lines) Fax : 91 11 3234062, 3239399, 3239382 Email- bis@vsnal.com	<ul style="list-style-type: none"> ⊙ Bureau of Indian Standards Committees on Earthquake Engineering and Wind Engineering have a Seismic Zoning Map and the Wind Velocity Map including cyclonic winds for the country
4. Central Water Commission (CWC) Sewa Bhawan, R.K.Puram New Delhi - 110066 cmanoff@niccwc.delhi.nic.in RO- Bangalore, Bhopal, Bhubaneshwar, Chandigarh, Coimbatore/Chennai, Delhi, Hyderabad, Lucknow, Nagpur, Patna, Shillong, Siliguri and Vadodara	<ul style="list-style-type: none"> ⊙ Central Data Bank -Collection, collation and Publishing of Hydrological, Hydrometeorological, Sediment and Water Quality data- ⊙ Basin wise Master Plans ⊙ Flood atlas for India ⊙ Flood Management and Development and Operation of Flood Forecasting System- CWC operate a network of forecasting stations Over 6000 forecasts are issued every year with about 95% of the forecasts within the permissible limit. ⊙ Water Year Books, Sediment Year Books and Water Quality Year Books. ⊙ Also actively involved in monitoring of 84 identified projects through National, State and Project level Environmental Committees for ensuring implementation of environmental safeguards
5. Central Ground Water Board (HO) N.H.IV, New CGO Complex, Faridabad - 121001 RO - Guwahati, Chandigarh, Ahemadabad, Trivandrum, Calcutta, Bhopal, Lucknow, Banglore, Nagpur, Jammu, Bhubneshwar, Raipur, Jaipur, Chennai, Hyderabad, Patna	<ul style="list-style-type: none"> ⊙ surveys, exploration, monitoring of ground water development

¹⁶ Based on web search and literature review

6.	Central Pollution Control Board Parivesh Bhawan, CBD-cum-Office Complex East Arjun Nagar, DELHI - 110 032 INDIA E-mail : cpcb@alpha.nic.in	<ul style="list-style-type: none"> ⊗ National Air Quality Monitoring Programme ⊗ National River Water Quality Monitoring Programme- Global Environment Monitoring , MINARS ⊗ Zoning Atlas Programme ⊗ Information on 17 polluting category industries (inventory, category wise distribution, compliance, implementation of pollution control programmes)
7.	Central Arid Zone Research Institute, Jodhpur Email : cazri@x400.nicgw.nic.in Regional Centre at Bhuj in Gujarat	<ul style="list-style-type: none"> ⊗ AGRIS database on all aspects of agriculture from 1975 to date ⊗ Also have cell on Agriculture Research Information System; ⊗ Working on ENVIS project on desertification ⊗ Repository of information on the state of natural resources and desertification processes and their control ⊗ The spectrum of activities involves researches on basic resource inventories; monitoring of desertification, rehabilitation and management of degraded lands and other areas
8.	Central Inland Capture Fisheries Research Institute, Barrackpore- 743101, Tel#033-5600177 Fax#033-5600388 Email : cicfri@x400.nicgw.nic.in	<ul style="list-style-type: none"> ⊗ Data Base on Ecology and fisheries of major river systems of India. Biological features of commercially important riverine and estuarine fish species. Production functions and their interactions in floodplain wetlands. ⊗ Activities - Environmental Impact Assessment for Resource Management ; Fisheries Resource surveys
9.	Central Institute of Brackish Water Aquaculture 141, Marshalls Road, Egmore , Chennai - 600 008, Tel# 044-8554866, 8554891, Director (Per) 8554851 Fax#8554851,	<ul style="list-style-type: none"> ⊗ Repository of information on brackish water fishery resources with systematic database of coastal fishery resources for ARIS ⊗ Agricultural Research Information System (ARIS) database covers State wise data on soil and water quality parameters, land use pattern, production and productivity trends, ⊗ Social, economic and environmental impacts of aquaculture farming, ⊗ Guidelines and effluent standards for aquaculture farming
10.	Central Marine Fisheries Research Institute (CMFRI), Cochin	<ul style="list-style-type: none"> ⊗ Assessing and monitoring of exploited and un-exploited fish stocks in Indian EEZ ⊗ Monitoring the health of the coastal ecosystems, particularly the endangered ecosystems in relation to artisanal fishing, mechanised fishing and marine pollution ⊗ The institute has been collecting data on the catch and effort and biological characteristics for nearly half a century based on scientifically developed sampling scheme, covering all the maritime States of the country ⊗ The voluminous data available with the institute is managed by the National Marine Living Resources Data Centre (NMLRDC)
11.	Central Water and Power Research Station, Pune Tel#020-4391801-14; 4392511; 4392825 Fax #020-4392004,4390189	<ul style="list-style-type: none"> ⊗ Numerical and Physical models for hydro-dynamic simulations
12.	Central Institute of Road Transport, Bhosari, Pune 411 026, India. Tel : +91 (20) 7125177, 7125292, 7125493, 7125494	<ul style="list-style-type: none"> ⊗ Repository of data on all aspects of performance of STUs and a host of other related road transport parameters

13. Department of Ocean Development	<ul style="list-style-type: none"> ⑨ Assessment of environment parameters and marine living resources (primary and secondary) in Indian EEZ (Nodal Agency NIO Kochi) ⑨ Stock assessment, biology and resource mapping of deep sea shrimps, lobsters and fishes in Indian EEZ (Nodal agency-Fisheries Survey of India) ⑨ Investigations of toxical algal blooms and benthic productivity in Indian EEZ (Nodal agency- Cochin University of Science and technology) ⑨ Coastal Ocean Monitoring and Prediction System (COMAP) - monitoring and modelling of marine pollution along entire Indian coast and islands. Parameters monitored are temp, salinity, DO, pH, SS, BOD, inorganic phosphate, nitrate, nitrite, ammonia, total phosphorus, total nitrite, total organic carbon, petroleum hydrocarbons, pathogenic vibrios, pathogenic E.coli, shigella, salmonella, heavy metals (Cd, Hg, Pb) and pesticide residues (DDT, BHC, Endosulfan). Monitoring is carried out along the ecologically sensitive zones and urban areas (NIO Mumbai- Apex coordinating agency). ⑨ Sea Level Measurement Programme (SELMAM)- sea level measurement at selected stations (Porbandar, Bombay, Goa, Cochin, Tuticorin, Madras, Machilipatnam, Visakhapatnam, Paradeep, Calcutta and Kavaratti (Lakshadweep Island)) along Indian coast and islands using modern tide gauges ⑨ Detailed coastal maps through Survey of India showing contour at 1/2 a metre interval in the scale of 1:25000. (Nellore- Machhalipatnam work already over) ⑨ Marine Data Centre (MDC) IMD for Ocean surface meteorology, GSI for marine geology, SOI for tide levels, Naval Hydrographic Office for bathymetry, NIO Goa for physical chemical and biological oceanography, NIO Mumbai for marine pollution, CMFRI for coastal fisheries, Institute of Ocean Management Madras for coastal geomorphology ⑨ DOD has setup Indian National Centre for Ocean Information Services (INCOIS) at Hyderabad for generation and dissemination of ocean data products (near real time data products such as sea surface temperature, potential fishing zones, upwelling zones, maps, eddies, chlorophyll, suspended sediment load etc). MDC will be integrated with INCOIS ⑨ Integrated Coastal and Marine Area Management (ICMAM) programme - GIS based information system for management of 11 critical habitats namely Pichavaram, Karwar, Gulf of Mannar, Gulf of Khambat, Gulf of Kutch, Malvan, Cochin, Coringa mangroves, Gahirmata, Sunderbans and Kadamat (Lakshadweep) ⑨ Wetland maps for Tamil Nadu and Kerala showing the locations of lagoons, backwaters, estuaries, mudflats etc (1:50000 scale) ⑨ Coral Reef Maps for Gulf of Kachch, Gulf of Mannar, Andaman and Nicobar and Lakshadweep Islands (1:50,000 scale) indicating the condition of corals, density etc
14. Environment Protection Training and Research Institute Gachibowli, Hyderabad - 500 019, India Phone: +91-40-3001241, 3001242, 3000489 Fax: +91-40- 3000361 E-mail: info@eptri.com	<ul style="list-style-type: none"> ⑨ Environment Information Centre- has appointed EPTRI as the Distributed Information Centre for the Eastern Ghats region of India. EIC Collaborates with the Stockholm Environment Institute Sweden Database on Economics of Industrial Pollution Prevention in India Database of Large and Medium Scale Industries of Andhra Pradesh Environmental Status of the Hyderabad Urban Agglomeration Study on 'water pollution-health linkages' for a few Districts of A.P

		<ul style="list-style-type: none"> ⑨ Environment Quality Mapping <ul style="list-style-type: none"> Macro level studies for six districts in the State of Andhra Pradesh Micro level studies for two study zones presenting the permissible pollutant load and scoping for new industrial categories Zonation of the IDA, Parwada which helped APIIC to promote the land for industrial development Disaster management plan for Visakhapatnam Industrial Bowl Area
15.	<p>Forest Survey of India (FSI) Kaulagarh Road, P.O., IPE Dehradun - 248 195 Tel# 0135-756139, 755037, 754507 Fax # 91-135-759104 E-Mail : fsidir@nde.vsnl.net.in fsihq@nde.vsnl.net.in</p> <p>RO- Banglore, Calcutta, Nagpur and Shimla</p>	<ul style="list-style-type: none"> ⑨ State of Forest Report (Biannual) ⑨ National Forest Vegetation Map (Biannual exercise) (on 1: 1 million scale) ⑨ Thematic mapping on 1:50,000 scale depicting the forest type, species composition, crown density of forest cover and other landuse National ⑨ Basic Forest Inventory System ⑨ Inventory survey of non forest area ⑨ Forest inventory report providing details of area estimates, topographic description, health of forest, ownership pattern, estimation of volume and other growth parameters such as height and diameter in different types of forest, estimation of growth, regeneration and mortality of important species, volume equation and wood consumption of the area studied
16.	<p>Geological Survey of India 27 Jawaharlal Nehru Road, Calcutta 700 016, India Telephone +91-33-2496941 FAX 91-33-2496956 gsi_chq@vsnl.com</p>	<ul style="list-style-type: none"> ⑨ Environmental hazards zonation mapping in mineral sector ⑨ Codification of base line information of geo-environmental appreciation of any terrain and related EIA and EMP studies ⑨ Lineament and geomorphological map of India on 1:20,000 scale. ⑨ Photo-interpreted geological and structural maps of terrains with limited field checks.
17.	<p>Indian Council of Agriculture Research, Krishi Bhawan, New Delhi, Tel#011-338206</p> <ul style="list-style-type: none"> - ICAR complex, Goa- Agro metrology - Central Arid Zone Research Institute- Agro forestry - Central Soil salinity Research Institute, - Indian Institute of Soil Science - Central Soil and Water Conservation Research and Training Institute - National Bureau of Soil Survey and Landuse Planning 	<ul style="list-style-type: none"> ⑨ A total of 80,000 profiles at 10 kms grid across the country were analyzed to characterize the soils of India. ⑨ Detailed soil maps of the Country (1:7 million), State (1:250,000) and districts map (1:50,000) depicting extent of degradation (1:4.4 millions) have been prepared. ⑨ Thematic maps depicting soil depth, texture drainage, calcareousness, salinity, pH, slope and erosion have been published ⑨ Agro-climate characterization of the country based on moisture, thermal and sunshine regimes ⑨ Agro-ecological zones (20) and sub-zones (60) for the country were delineated based on physiography, soils, climate, Length of Growing Period and Available Water Content, and mapped on 1:4.4 million scale. ⑨ Digitization of physiography and soil resource base on 1:50,000 scale for 14 States have been completed. ⑨ .Soil fertility maps of N,P,K,S and Zn have also been developed ⑨ Water quality guidelines for irrigation and naturally occurring saline/sodic water ⑨ Calibration and verification of ground water models for predicting water logging and salinity hazards in irrigation commands
18.	<p>Indian Bureau of Mines Indira Bhawan, Civil Lines Nagpur Ph no - 0712-533 631, Fax- 0712-533 041</p>	<ul style="list-style-type: none"> ⑨ National mineral inventory for 61 minerals and mineral maps ⑨ Studies on environmental protection and pollution control in regard to the mining and mineral beneficiation operations ⑨ Collection, processing and storage of data on mines, minerals and mineral-based industries, collection and maintenance of world mineral intelligence, foreign mineral legislation and other related matters

19.	Indian Meteorology Department Shivaji nagar, Pune 41100 RO- Mumbai, Chennai, Calcutta, New Delhi, Nagpur, Guwahati	<ul style="list-style-type: none"> ⊙ Meteorological data ⊙ Background air quality monitoring network under Global Atmospheric Watch Programme (operates 10 stations) ⊙ Seismicity map, seismic zoning map; seismic occurrences and cyclone hazard monitoring; list of major earthquakes ⊙ Climatological Atlas of India , Rainfall Atlas of India and Agroclimatic Atlas of India ⊙ Monthly bulletin of Climate Diagnostic Bulletin of India ⊙ Environmental Meteorological Unit of IMD at Delhi to provide specific services to MoEF
20.	INTACH Natural Heritage, 71 Lodi Estate, New Delhi-110 003 Tel. 91-11-4645482, 4632267/9, 4631818, 4692774, 4641304 Fax : 91- 11-4611290 E-mail : nh@intach.net	<ul style="list-style-type: none"> ⊙ Listing and documentation of heritage sites identified by municipalities and local bodies (Listing excludes sites and buildings under the purview of the Archaeological Survey of India and the State Departments of Archaeology)
21.	Industrial Toxicology Research Centre Post Box No. 80, Mahatma Gandhi Marg, Lucknow-226001, Phone: +91-522- 221856,213618,228227; Fax : +91- 522 228227 Email: itrc@itrcindia.org	<ul style="list-style-type: none"> ⊙ Activities include health survey on occupational diseases in industrial workers, air and water quality monitoring studies, ecotoxicological impact assessment, toxicity of chemicals, human health risk assessment ⊙ Five databases on CD-ROM in the area of environmental toxicology viz: TOXLINE, CHEMBANK, POISINDEX, POLTOX and PESTBANK. The Toxicology Information Centre provides information on toxic chemicals including household chemicals ⊙ ENVIS centre and created a full-fledged computerized database (DABTOC) on toxicity profiles of about 450 chemicals
22.	Indian Institute of Forest Management Post Box No. 357, Nehru Nagar Bhopal - 462 003 Phone # 0755-575716, 573799, 765125, 767851 Fax # 0755-572878	<ul style="list-style-type: none"> ⊙ Consultancy and research on joint forest management (Ford Foundation, SIDA, GTZ, FAO etc)
23.	Indian Institute of Petroleum Mohkampur , Dehradun, India, 248005 0135- 660113 to 116 0135- 671986	<ul style="list-style-type: none"> ⊙ Fuel quality characterisation ⊙ Emission factors
24.	Ministry of Environment and Forest	<ul style="list-style-type: none"> ⊙ Survey of natural resources ⊙ National river conservation directorate ⊙ Environmental research programme for eastern and western ghats ⊙ National natural resource management system ⊙ Wetlands conservation programme- survey, demarcation, mapping landscape planning, hydrology for 20 identified wetlands National wasteland identification programme
25.	Mumbai Metropolitan Regional Development Authority	<ul style="list-style-type: none"> ⊙ Mumbai Urban Transport Project ⊙ Mumbai Urban Development Project ⊙ Mumbai Urban Rehabilitation Project ⊙ Information on MMR; statistics on councils and corporations Regional Information Centre- Basic data on population, employment, industries and other sectors are regularly collected and processed

26.	Municipal Corporation of Greater Mumbai	<ul style="list-style-type: none"> ⊗ Air Quality Data for Mumbai Municipal Area ⊗ Water quality of lakes used for water supply to Mumbai
27.	Ministry of Urban Development Disaster Mitigation and Vulnerability Atlas of India Building Materials & Technology Promotion Council G-Wing, Nirman Bhavan, New Delhi-110011 Tel: 91-11-3019367 Fax: 91-11-3010145 E-Mail: bmtpc@del2.vsnl.net.in	<ul style="list-style-type: none"> ⊗ Identification of hazard prone area ⊗ Vulnerability Atlas showing areas vulnerable to natural disasters ⊗ Land-use zoning and design guidelines for improving hazard resistant construction of buildings and housing ⊗ State wise hazard maps (on cyclone, floods and earthquakes)
28.	Natural Disaster Management Division in Department of Agriculture and Cooperation	⊗ Weekly situation reports on recent disasters, reports on droughts, floods, cyclones and earthquakes
29.	National Bureau Of Soil Survey & Land Use Planning P.O. Box No. 426, Shankar Nagar P.O., Nagpur-440010 Tel#91-712-534664,532438,534545 Fax#:91-712-522534 RO- Nagpur, New Delhi, Bangalore, Calcutta, Jorhat, Udaipur	<ul style="list-style-type: none"> ⊗ NBSS&LUP Library has been identified as sub centre of ARIC (ICAR) for input to AGRIS covering soil science literature generated in India ⊗ Research in weathering and soil formation, soil morphology, soil mineralogy, physicochemical characterisation, pedogenesis, and landscape-climate-soil relationship. ⊗ Soil Series of India- The soils are classified as per Soil Taxonomy. The described soil series now belong to 17 States of the country. ⊗ Landuse planning- watershed management, land evaluation criteria, crop efficiency zoning ⊗ Soil Information system is developed state-wise at 1:250,000 scale. Presently the soil maps of all the States are digitized, processed and designed for final output both digital and hardcopy. The thematic layers and interpreted layers of land evaluation (land capability, land irrigability and crop suitability), Agro-Ecological Zones and soil degradation themes are prepared. ⊗ Districts level information system is developed for about 15 districts at 1:50,000 scale. The soil information will be at soil series level in this system. Soil resource inventory of States, districts water-sheds (1:250,000; 1:50,000; 1:10,000/8000)
30.	National Institute of Ocean Technology, Velacherry-Tambaram main road Narayanapuram Chennai, Tamil Nadu Tel#91-44-2460063 / 2460064/ 2460066/ 2460067 Fax#91-44-2460645	<ul style="list-style-type: none"> ⊗ Waste load allocation in selected estuaries (Tapi estuary and Ennore creek) is one the components under the Integrated Coastal and Marine Area Management (ICMAM) programme of the Department of Ocean Development ICMAM is conducted with an IDA based credit to the Government of India under the Environmental Capacity Building project of MoEF (waste assimilation capacity of Ennore creek is over) ⊗ Physical oceanographic component of Coastal & Ocean monitoring Predictive System (COMAPS) a long term monitoring program under the Department of Ocean Development ⊗ Identification of suitable locations for disposal of dredge spoil using mathematical models & environmental criteria ⊗ EIA Manual and EIA guidelines for port and harbour projects
31.	National Institute of Oceanography, Goa RO- Mumbai, Kochi	<ul style="list-style-type: none"> ⊗ Coastal Ocean Monitoring and Predictions(COMAP)-Monitoring of coastal waters for physicochemical and biological parameters including petroleum hydrocarbons, trace metals, heavy metals, and biomass of primary (phytoplankton) and secondary (zooplankton, microbial and benthic organisms) ⊗ Marine Biodiversity of selected ecosystem along the West Coast of India

32.	National Botanical Research Institute, Post Box No 436 Rana Pratap Marg Lucknow- 226001, Tel: (+91) 522 271031-35 Fax: (+91) 522 282849, 282881 Lucknow	<ul style="list-style-type: none"> ⊗ Dust filtering potential of common avenue trees and roadside shrubs has been determined, besides studies have also been conducted on heavy-metals accumulation potential of aquatic plants supposedly useful as indicators of heavy metal pollution in water bodies and capable of reducing the toxic metals from water bodies. ⊗ Assessment of bio-diversity of various regions of India
33.	National Geophysical Research Institute, Uppal Road, Hyderabad Telephone:0091-40-7171124, FAX:0091-40-7171564	<ul style="list-style-type: none"> ⊗ Exploration, assessment and management of ground water resources including ground water modelling and pollution studies
34.	National Environmental Engineering Research Institute, Nagpur RO- Mumbai, Delhi, Chennai, Calcutta, Ahmedabad, Cochin, Hyderabad, Kanpur	<ul style="list-style-type: none"> ⊗ National Air Quality Monitoring (NAQM) for CPCB ⊗ Database on cleaner technologies of industrial productions
35.	National Hydrology Institute, Roorkee RO- Belgaum (Hard Rock Regional Centre), Jammu (Western Himalayan Regional Centre), Guwahati (North Eastern Regional Centre), Kakinada (Deltaic Regional Centre), Patna (Ganga Plains North Regional Centre), and Sagar (Ganga Plains South)	<ul style="list-style-type: none"> ⊗ Basin studies, hydrometeorological network improvement, hydrological year book, hydrological modelling, regional flood formulae, reservoir sedimentation studies, environmental hydrology, watershed development studies, tank studies, and drought studies.
36.	National Institute Of Urban Affairs, India Habitat Centre, New Delhi	<ul style="list-style-type: none"> ⊗ Urban Statistics Handbook
37.	National Institute of Occupational Health Meghaninagar, Ahmedabad RO- Banglore, Calcutta	<ul style="list-style-type: none"> ⊗ epidemiological studies and surveillance of hazardous occupations including air pollution, noise pollution, agricultural hazards, industrial hazards in organised sectors as well as small scale industries, carcinogenesis, pesticide toxicology, etc ⊗ WHO collaborative centre for occupational health for South East Asia region and the lead institute for the international programme on chemical safety under IPCS (WHO)
38.	NRSA Data Centre Department of Space, Balanagar, Hyderabad 500 037 Ph- 040-3078560 3078664 sales@nrsa.gov.in	<ul style="list-style-type: none"> ⊗ Satellite data products (raw data, partially processed (radiometrically corrected but geometrically uncorrected), standard data (radiometrically and geometrically corrected), geocoded data(1:50,000 and 1:25000 scale), special data products like mosaiced, merged and extracted) available on photographic (B&W and FCC in form of film of 240 mm X 240mm or enlargements/paper prints in scale varying between 1:1M and 1:12500 and size varying between 240mm and 1000mm) and digital media (CD-ROMs, 8 mm tapes)
39.	Rajiv Gandhi National Drinking Water Mission	<ul style="list-style-type: none"> ⊗ Database for groundwater using remote sensing technology (Regional Remote Sensing Service Centre involved in generation of ground water prospect maps at 1:50,000 scale for the State of Kerala, Karnataka, AP, MP and Rajasthan for RGNDWM)
40.	Space Application Centre Value Added Services Cell (VASC) Remote Sensing Application Area Ahmedabad 380 053 079-676 1188	<ul style="list-style-type: none"> ⊗ National Natural Resource Information System ⊗ Landuse mapping for coastal regulation zone (construction setback line) upto 1:12500 scale ⊗ Inventory of coastal wetlands, coral reefs, mangroves, seaweeds ⊗ Monitoring and condition assessment of protected coastal areas

	Fax- 079-6762735	<ul style="list-style-type: none"> ⊙ Wetland mapping and inventory ⊙ Mapping of potential hotspots and zoning of environmental hazards ⊙ General geological and geomorphological mapping in diverse terrain ⊙ Landslide risk zonation for Tehre area
41.	State Pollution Control Board	<ul style="list-style-type: none"> ⊙ State Air Quality Monitoring Programme ⊙ Inventory of polluting industries ⊙ Identification and authorization of hazardous waste generating industries ⊙ Inventory of biomedical waste generating industries ⊙ Water quality monitoring of water bodies receiving wastewater discharges ⊙ Inventory of air polluting industries ⊙ Industrial air pollution monitoring ⊙ Air consent, water consent, authorization, environment monitoring reports
42.	State Ground Water Board	
43.	Survey of India	<ul style="list-style-type: none"> ⊙ Topographical surveys on 1:250,000 scales, 1:50,000 and 1:25,000 scales ⊙ Digital Cartographical Data Base of topographical maps on scales 1:250,000 and 1:50,000 ⊙ Data generation and its processing for redefinition of Indian Geodetic Datum ⊙ Maintenance of National Tidal Data Centre and receiving/ processing of tidal data of various ports. ⊙ Coastal mapping along the Eastern coast line has been in progress to study the effect of submergence due to rise in sea-level and other natural phenomenon. Ground surveys have been completed for the proposed coastal region and maps are under printing. ⊙ District planning maps containing thematic information (135 maps) have been printed out of 249 maps covering half the districts of India. Districts planning maps for remaining half of the area are being processed by National Atlas and Thematic Mapping Organisation (NATMO)
44.	Town and Country Planning Organisation	<ul style="list-style-type: none"> ⊙ Urban mapping - Thematic maps and graphic database on towns (under progress in association with NRSA and State town planning department)
45.	Wildlife Institute of India Post Bag No. 18, Chandrabani Dehradun - 248 001, Uttaranchal Tel#0135 640111 -15, Fax#0135 640117 email : wii@wii .	<ul style="list-style-type: none"> ⊙ Provide information and advice on specific wildlife management problems. ⊙ National Wildlife Database
46.	Zoological Survey of India Prani Vigyan Bhawan 'M' Block, New Alipore Calcutta - 700 053 Phone # 91-33-4786893, 4783383 Fax # 91-33-786893 RO - Shillong, Pune, Dehradun, Jabalpur, Jodhpur, Chennai, Patna, Hyderabad, Canning, Behrampur, Kozikode, Itanagar, Digha, Port Blair, Solan	<ul style="list-style-type: none"> ⊙ Red Book for listing of endemic species ⊙ Survey of faunal resources

ANNEXURE X
Impact Prediction Tools

Table 1: Choice of Models for Impact Prediction: Air Environment*

Model	Application	Remarks
ISCST 3	<ul style="list-style-type: none"> ▪ Appropriate for point, area and line sources ▪ Application for flat or rolling terrain ▪ Transport distance up to 50 km valid ▪ Computes for 1 hr to annual averaging periods 	<ul style="list-style-type: none"> ▪ Can take up to 99 sources ▪ Computes concentration on 600 receptors in Cartesian on polar coordinate system ▪ Can take receptor elevation ▪ Requires source data, meteorological and receptor data as input.
AERMOD with AERMET	<ul style="list-style-type: none"> ▪ Settling and dry deposition of particles; ▪ Building wake effects (excluding cavity region impacts); ▪ Point, area, line, and volume sources; ▪ Plume rise as a function of downwind distance; ▪ Multiple point, area, line, or volume sources; ▪ Limited terrain adjustment; ▪ Long-term and short-term averaging modes; ▪ Rural or urban modes; ▪ Variable receptor grid density; ▪ Actual hourly meteorology data 	<ul style="list-style-type: none"> ▪ Can take up to 99 sources ▪ Computes concentration on 600 receptors in Cartesian on polar coordinate system ▪ Can take receptor elevation ▪ Requires source data, meteorological and receptor data as input.
PTMAX	<ul style="list-style-type: none"> ▪ Screening model applicable for a single point source ▪ Computes maximum concentration and distance of maximum concentration occurrence as a function of wind speed and stability class 	<ul style="list-style-type: none"> ▪ Require source characteristics ▪ No met data required ▪ Used mainly for ambient air monitoring network design
PTDIS	<ul style="list-style-type: none"> ▪ Screening model applicable for a single point source ▪ Computes maximum pollutant concentration and its occurrences for the prevailing meteorological conditions 	<ul style="list-style-type: none"> ▪ Require source characteristics ▪ Average met data (wind speed, temperature, stability class <i>etc.</i>) required ▪ Used mainly to see likely impact of a single source
MPTR	<ul style="list-style-type: none"> ▪ Appropriate for point, area and line sources applicable for flat or rolling terrain ▪ Transport distance up to 50 km valid ▪ Computes for 1 hr to annual averaging periods ▪ Terrain adjustment is possible 	<ul style="list-style-type: none"> ▪ Can take 250 sources ▪ Computes concentration at 180 receptors up to 10 km ▪ Requires source data, meteorological data and receptor coordinates
CTDM PLUS (Complex Terrain Dispersion Model)	<ul style="list-style-type: none"> ▪ Point source steady state model, can estimate hrly average concentration in isolated hills/array of hills 	<ul style="list-style-type: none"> ▪ Can take maximum 40 Stacks and computes concentration at maximum 400 receptors ▪ Does not simulate calm met conditions ▪ Hill slopes are assumed not to exceed 15 degrees ▪ Requires sources, met and terrain characteristics and receptor details
UAM (Urban	<ul style="list-style-type: none"> ▪ 3-D grid type numerical simulation model ▪ Computes O₃ concentration short term 	<ul style="list-style-type: none"> ▪

Model	Application	Remarks
Airshed Model)	<p>episodic conditions lasting for 1 or 2 days resulting from NO_x and VOCs</p> <ul style="list-style-type: none"> ▪ Appropriate for single urban area having significant O₃ problems 	
RAM (Rural Airshed Model)	<ul style="list-style-type: none"> ▪ Steady state Gaussian plume model for computing concentration of relatively stable pollutants for 1 hr to 1 day averaging time ▪ Application for point and area sources in rural and urban setting 	<ul style="list-style-type: none"> ▪ Suitable for flat terrains ▪ Transport distance less than 50 km.
CRESTER	<ul style="list-style-type: none"> ▪ Applicable for single point source either in rural or urban setting ▪ Computes highest and second highest concentration for 1hr, 3hr, 24hr and annual averaging times ▪ Tabulates 50 highest concentration for entire year for each averaging times 	<ul style="list-style-type: none"> ▪ Can take up to 19 Stacks simultaneously at a common site. ▪ Unsuitable for cool and high velocity emissions ▪ Do not account for tall buildings or topographic features ▪ Computes concentration at 180 receptor, circular wing at five downwind ring distance 36 radials ▪ Require sources, and met data
OCD (Offshore and coastal Dispersion Model)	<ul style="list-style-type: none"> ▪ It determines the impact of offshore emissions from point sources on the air quality of coastal regions ▪ It incorporates overwater plume transport and dispersion as well as changes that occur as the plume crosses the shore line ▪ Most suitable for overwater sources shore onshore receptors are below the lowest shore height 	<ul style="list-style-type: none"> ▪ Requires source emission data ▪ Require hrly met data at offshore and onshore locations like water surface temperature; overwater air temperature; relative humidity <i>etc.</i>
FDM (Fugitive Dust Model)	<ul style="list-style-type: none"> ▪ Suitable for emissions from fugitive dust sources ▪ Source may be point, area or line (up to 121 source) ▪ Require particle size classification max. up to 20 sizes ▪ Computes concentrations for 1 hr, 3hr, 8hr, 24hr or annual average periods 	<ul style="list-style-type: none"> ▪ Require dust source particle sizes ▪ Source coordinates for area sources, source height and geographic details ▪ Can compute concentration at max. 1200 receptors ▪ Require met data (wind direction, speed, Temperature, mixing height and stability class) ▪ Model do not include buoyant point sources, hence no plume rise algorithm
RTDM (Rough Terrain Diffusion Model)	<ul style="list-style-type: none"> ▪ Estimates GLC is complex/rough (or flat) terrain in the vicinity of one or more co-located point sources ▪ Transport distance max. up to 15 km to up to 50 km ▪ Computes for 1 to 24 hr. or annual average concentrations 	<ul style="list-style-type: none"> ▪ Can take up to 35 co-located point sources ▪ Require source data and hourly met data ▪ Computes concentration at maximum 400 receptors ▪ Suitable only for non reactive gases ▪ Do not include gravitational effects or depletion mechanism such as rain/ wash out, dry deposition
CDM(Climatolo	<ul style="list-style-type: none"> ▪ It is a climatologically steady state GPM for 	<ul style="list-style-type: none"> ▪ Suitable for point and area sources

Model	Application	Remarks
gically Dispersion Model)	determining long term (seasonal or annual) <ul style="list-style-type: none"> Arithmetic average pollutant concentration at any ground level receptor in an urban area 	in urban region, flat terrain <ul style="list-style-type: none"> Valid for transport distance less than 50 km Long term averages: One month to one year or longer
PLUVUE-II (Plume Visibility Model)	<ul style="list-style-type: none"> Applicable to assess visibility impairment due to pollutants emitted from well defined point sources It is used to calculate visual range reduction and atmospheric discoloration caused by plumes It predicts transport, atmospheric diffusion, chemical, conversion, optical effects, and surface deposition of point source emissions. 	<ul style="list-style-type: none"> Require source characteristics, met data and receptor coordinates & elevation Require atmospheric aerosols (back ground & emitted) characteristics, like density, particle size Require background pollutant concentration of SO₄, NO₃, NO_x, NO₂, O₃, SO₂ and deposition velocities of SO₂, NO₂ and aerosols
MESO-PUFF II (Meso scale Puff Model)	<ul style="list-style-type: none"> It is a Gaussian, Variable trajectory, puff superposition model designed to account for spatial and temporal variations in transport, diffusion, chemical transformation and removal mechanism encountered on regional scale. Plume is modeled as a series of discrete puffs and each puff is transported independently Appropriate for point and area sources in urban areas Regional scale model. 	<ul style="list-style-type: none"> Can model five pollutants simultaneously (SO₂, SO₄, NO_x, HNO₃ and NO₃) Require source characteristics Can take 20 point sources or 5 area source For area source – location, effective height, initial puff size, emission is required Computes pollutant concentration at max. 180 discrete receptors and 1600 (40 x 40) grided receptors Require hourly surface data including cloud cover and twice a day upper air data (pressure, temp, height, wind speed, direction) Do not include gravitational effects or depletion mechanism such as rain/ wash out, dry deposition

Table 2: Choice of Models for Impact Modeling: Noise Environment *

Model	Application
FHWA (Federal Highway Administration)	Noise Impact due to vehicular movement on highways
Dhwani	For predictions of impact due to group of noise sources in the industrial complex (multiple sound sources)
Hemispherical sound wave propagation Air Port	Fore predictive impact due to single noise source For predictive impact of traffic on airport and rail road

Table 3: Choice of Models for Impact Modeling: Land Environment *

Model	Application	Remarks
Digital Analysis Techniques	Provides land use / land cover distribution	
Ranking analysis for soil suitability criteria	Provides suitability criteria for developmental conversation activities	Various parameters viz. depth, texture, slope, erosion status, geomorphology, flooding hazards, GW potential, land use <i>etc.</i> , are used.

Table 4: Choice of Models for Impact Modeling: Biological Environment *

Name	Relevance	Applications	Remarks
Flora			
Sample plot methods	Density and relative density Density and relative dominance	Average number of individuals species per unit area Relative degree to which a species predominates a community by its sheer numbers, size bulk or biomass	The quadrant sampling technique is applicable in all types of plant communities and for the study of submerged, sessile (attached at the base) or sedentary plants
	Frequency and relative frequency importance value	Plant dispersion over an area or within a community	Commonly accepted plot size: 0.1 m ² - mosses, lichens & other mat-like plants
		Average of relative density, relative dominance and relative frequency	0.1 m ² - herbaceous vegetation including grasses
			10.20 m ² – for shrubs and saplings up to 3m tall, and
			100 m ² – for tree communities
Transects & line intercepts methods	Cover	Ratio of total amount of line intercepted by each species and total length of the line intercept given its cover	This methods allows for rapid assessment of vegetation transition zones, and requires minimum time or equipment of establish
	Relative dominance	It is the ratio of total individuals of a species and total individuals of all species	Two or more vegetation strata can be sampled simultaneously
Plot-less sampling methods	Mean point plant Mean area per plant	Mean point – plant distance Mean area per plant	Vegetation measurements are determined from points rather than being determined in an area with boundaries

Name	Relevance	Applications	Remarks
	Density and relative density		Method is used in grass-land and open shrub and tree communities
	Dominance and relative dominance		It allows more rapid and extensive sampling than the plot method
	Importance value		Point- quarter method is commonly used in woods and forests.
Fauna			
Species list methods	Animal species list	List of animal communities observed directly	Animal species lists present common and scientific names of the species involved so that the faunal resources of the area are catalogued
Direct Contact Methods	Animal species list	List of animals communities observed directly	This method involves collection, study and release of animals
Count indices methods (Roadside and aerial count methods)	Drive counts Temporal counts	Observation of animals by driving them past trained observers	Count indices provide estimates of animal populations and are obtained from signs, calls or trailside counts or roadside counts
	Call counts	Count of all animals passing a fixed point during some stated interval of time	These estimates, through they do not provide absolute population numbers, Provide an index of the various species in an area
			Such indices allow comparisons through the seasons or between sites or habitats
Removal methods	Population size	Number of species captured	Removal methods are used to obtain population estimates of small mammals, such as, rodents through baited snap traps
Market capture methods	Population size estimate (M)	Number of species originally marked (T) Number of marked animals recaptured (t) and total number of animals captured during census (n) $N = nT/t$	It involves capturing a portion of the population and at some later date sampling the ratio of marked to total animals caught in the population

Table 5: Choice of Models for Impact Predictions: Socio-economic Aspect *

Relevance		
Name	Application	Remarks
Extrapolative Methods	A prediction is made that is consistent with past and present socio-economic data, e.g. a prediction based on the linear extrapolation of current trends	
Intuitive Forecasting (Delphi techniques)	Delphi technique is used to determine environmental priorities and also to make intuitive predictions through the process of achieving group consensus	Conjecture Brainstorming Heuristic programming Delphi consensus
Trend extrapolation and correlation	Predictions may be obtained by extrapolating present trends Not an accurate method of making socio-economic forecasts, because a time series cannot be interpreted or extrapolated very far into the future with out some knowledge of the underlying physical, biological, and social factors	Trend breakthrough precursor events correlation and regression
Metaphors and analogies	The experience gained else where is used to predict the socio-economic impacts	Growth historical simulation commonsense forecasts
Scenarios	Scenarios are common-sense forecasts of data. Each scenario is logically constructed on model of a potential future for which the degrees of “confidence” as to progression and outcome remain undefined	Common-sense
Dynamic modeling (Input- Out model)	Model predicts net economic gain to the society after considering all inputs required for conversion of raw materials along with cost of finished product	
Normative Methods	Desired socio-economic goals are specified and an attempt is made to project the social environment backward in time to the present to examine whether existing or planned resources and environmental programmes are adequate to meet the goals	Morphological analysis technology scanning contextual mapping - functional array - graphic method Mission networks and functional arrays decision trees & relevance trees matrix methods scenarios

* **NOTE:** (i) If a project proponent prefer to use any model other than listed, can do so, with prior concurrence of concerned appraisal committee. (ii) Project-specific proposed prediction tools need to be identified by the project proponent and shall be incorporated in the draft ToR to be submitted to the Authority for the consideration and approval by the concerned EAC/SEAC.

ANNEXURE XI

**Form through which the State Governments/Administration of
the Union Territories Submit Nominations for SEIAA and SEAC
for the Consideration and Notification by the
Central Government**

Form for Nomination of a professional/expert as Chairperson / Member / Secretary of the SEIAA / EAC / SEAC						
1 Name (in block letters)						
2 Address for communication						
3 Age & Date of Birth (Shall be less than 67 years for the members and 72 years for the Chairman)						
4 Area of Expertise (As per Appendix VI)						
5	Professional Qualifications (As per Appendix VI)	Qualification(s)	University	Year of passing	Percentage of marks	
6	Work experience (High light relevant experience as per Appendix VI)	Position	Years of association		Nature of work. If required, attach separate sheets	
			From	to		Period in years
7	Present position and nature of job	Serving Central / State Government Office?			Yes/No	
		Engaged in industry or their associations?			Yes/No	
		Associated with environmental activism?			Yes/No	
		If no is the answer for above three, please specify the present position and name of the organization				
8	Whether experienced in the process of prior environmental clearance?	Yes/No. If yes, please specify the experience in a separate sheet (Please restrict to 500 words)				
9	Whether any out-standing expertise has been acquired?	Yes/ No If yes, please provide details in a separate sheet (Please restrict to 500 words).				
10	Any other relevant information?	May like to attach separate sheets (Research projects, consultancy projects, publications, memberships in associations, trainings undergone, international exposure cum experience etc.)				

The Government of.....is pleased to forward the Nomination of Dr./Sh. for the position of Chairperson / Member / Secretary of the SEIAA / SEAC / EAC to the Ministry of Environment & Forests, the Government of India for the Notification.

(Authorized Signature with Seal)

ANNEXURE XII
Composition of EAC/SEAC

Composition of the EAC/SEAC

The Members of the EAC shall be Experts with the requisite expertise and experience in the following fields /disciplines. In the event that persons fulfilling the criteria of “Experts” are not available, Professionals in the same field with sufficient experience may be considered:

- Environment Quality Experts: Experts in measurement/monitoring, analysis and interpretation of data in relation to environmental quality
- Sectoral Experts in Project Management: Experts in Project Management or Management of Process/Operations/Facilities in the relevant sectors.
- Environmental Impact Assessment Process Experts: Experts in conducting and carrying out Environmental Impact Assessments (EIAs) and preparation of Environmental Management Plans (EMPs) and other Management plans and who have wide expertise and knowledge of predictive techniques and tools used in the EIA process
- Risk Assessment Experts
- Life Science Experts in floral and faunal management
- Forestry and Wildlife Experts
- Environmental Economics Expert with experience in project appraisal

ANNEXURE XIII

Best Practices & Latest Technologies available and reference

Best Practices & Latest Technologies available and reference

The Government of India plans to study and possibly acquire new technologies from the cement industry of Japan. The government is discussing technology transfer in the field of energy conservation and environment protection to help improve efficiency of the Indian cement industry.

Under its Green Aid Plan, Japan's Ministry of Economy, Trade & Industry is providing assistance to a cement plant in India for implementing a project for power co-generation from waste heat for utilisation in the plant. Besides, the Japanese cement industry is using other superior technologies by utilising solid waste for producing eco-cement.

Kawasaki Heavy Industries, a leading manufacturer of high-performance cement plants, has supplied as many as 53 large-scale and energy-saving cement plants worldwide, including India. The company has produced various application plants such as limestone calcining system, fluidised bed limestone calcining system and fluidised bed coal moisture control system, while supplying cement plants.

New cement burning technique

FAKS or Fluidised Bed Advanced Cement Kiln System from KHIL is an innovative technology in cement burning, which is replacing the conventional rotary kiln system. Some of its features are:

- * High flexibility in fuel choices: Various coals are available, from low calorific value to low volatile coal such as petroleum coke.
- * Better thermal efficiency: 10-25 per cent reduction in heat consumption due to the configuration of the burning and cooling process by utilising the fluidised bed reactor.
- * Low environmental impact: 10-25 per cent reduction in CO₂ emission, 40 per cent or more reduction in NO_x emission.
- * Superior changeover productivity: Shorter changeover production time compared with conventional systems.
- * Economical advantages: 10-30 per cent of construction cost saving and around 70 per cent reduction in installation space, lower maintenance and running cost compared with conventional system.

Upgradation of Technology of Low Technology Cement Plants

The technological spectrum in the industry is very wide. At one end of the spectrum are the old wet process plants, while at the other end, are the new state-of-the-art technology plants presently being built by the Industry. In between these two extremes, are the large numbers of dry process plants built during the period 1965-90. These plants could not fully modernize or upgrade side by side with advent of newer technologies and had thus remained at intermediate technology level. Also, the level of technology is not same at all the plants built during the same period.

Majority of the cement plants in the country in the capacity range of 0.4 to 1.0 MTPA were set up more than 15-20 years ago i.e. before 1990's. They were based on state-of-art technology at that time. Since then, numerous developments have taken place in the cement manufacturing technology.

Though some of the old plants have been modernized to a limited extent by retrofitting the new technologies, substantial scope still exists for adopting the state-of-art technologies and bringing the old plants at par with world-class plants in terms of productivity, energy efficiency and environment friendliness, leading to cost competitiveness.

Moreover, the emission norms are likely to become more stringent in future and at the same time, the cement plants will be required to utilize waste derived raw materials and fuels to a large extent. The modifications of old plants to comply with these future requirements will also become inevitable. Therefore, there is a need to carry out a comprehensive assessment of all the earlier generation plants in the country to identify the extent of modernization required to improve their all round efficiency and enable them to meet the future criteria of viability, competitiveness and compliance with regard to energy consumption enabling them to comply with the provision of the Energy Conservation Act 2001.

Leading Experts

KHD Humboldt Wedag is a leading expert in modern grinding technology – designing, engineering and installing cement and minerals grinding plants across the world. KHD Tube Mills, Roller Presses and high efficient separators represents reliable and advanced high end process technology. Combining KHD Roller press and Separation technology in one hybrid system KHD concentrates grinding effectiveness and efficiency in narrow space.

Kiln plants from KHD Humboldt Wedag are top of the line. Highly efficient precalcining PYRO-Systems, rotary kilns on two piers with multi-channel burners for primary / secondary fuels, and clinker coolers with high recuperation efficiency are superior advantages for the customers. In addition to that modern KHD kiln plants fulfil high availability / stable operation and high specific through put rates to the capital outlay. Reduced emissions and flexibility to raw materials complete the benefits of KHD plants.

The **Loesche high efficiency classifier** produces products in a homogeneous field of streaming forces in conjunction with centrifugal forces.

Vane type classifier for the production of course and normal products

- Rotary classifier with or without central material feed
- High efficiency classifier
- The quality of the homogenous field can be optimized by static vanes in front of the cylindrical rotating vane cage.

The high efficiency classifier can be used on Loesche vertical roller mills and also for all air swept grinding mills.

The classifier is designed for central or without central material feed and can be used for all materials to be grind.

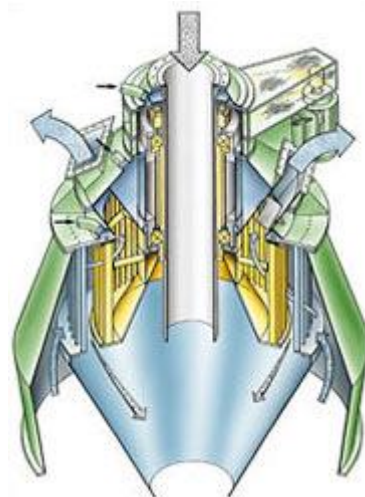

Perceived Benefits of Technology Upgradation

It is envisaged that the technology upgradation measures for the Pre-1990 era cement plants would result in :

- Increase in capacity : 2530 MTPA
- Reduction in thermal energy consumption : 1520 kcal/kg clinker
- Reduction in electrical energy consumption : 510 units/t
- Reduction in cost of production of cement : 5-10% because of above initiatives
- Reduction in energy costs through cōprocessing : 10–15%
- Reduction in the CO₂ emissions : 20% (through blended cements & energy conservation)

Future Modernization Needs of the Indian Cement Industry

Although the industry has largely set up plants with energy efficient equipment, there are still some areas for further improvements like:

- Appropriate preblending facilities for raw materials
- Fully automatic process control and monitoring facilities including auto samplers and controls.
- Appropriate cōprocessing technologies for use of hazardous and non hazardous wastes
- Interactive standard software expert packages for process and operation control with technical consultancy back-up
- Energy efficient equipment for auxiliary/minor operations
- Mechanized cement loading operations, palletization/shrink wrapping
- Bulk loading and transportation, pneumatic cement transport
- Low NO_x/SO₂ combustion systems and precalciners
- Standards for making composite cement so that all the flyash and other industrial wastes viz. slag are fully used.
- Cōgeneration of power through cost-effective waste heat recovery system (only one demonstration unit in operation)
- Horizontal roller mills (Horo Mills) for raw material and cement grinding
- Advanced computerized kiln control system based on artificial intelligence

Fuel Requirements and Alternate Sources of Energy

Fuel

Coal continues to be the main fuel for the Indian cement industry and will remain so in the near future as well. The industry is mainly using coal from various coalfields in the country. It is also procuring coal through open market and direct imports. Lignite from deposits in Gujarat and Rajasthan is also being used by cement plants. Pet coke has also been successfully utilized by some cement plants, mainly in Gujarat, Rajasthan and MP, thereby substituting main fossil and conventional fuel coal upto 100% in some plants. In the recent past, waste derived fuels including hazardous combustible wastes have also been tried due to economic pressures in cement manufacturing process owing to tough competition in domestic and global markets as well as ecological reasons on account of waste disposal and co-processing in cement rotary kilns being most effective mode of waste treatment.

Use of Industrial Wastes

- ❖ Cement plants in India utilized about 19% of flyash generated by power plants and 100% of granulated slag generated by steel plants (year 2005-06), as compared to almost 100% flyash and 84% of granulated slag in the Japanese cement industry.
- ❖ Recycling of Industrial wastes in manufacture of cement is highest in Japan followed by India.

Use of Alternate Fuels

- ❖ Use of hazardous and refuse derived combustibles and Municipal Solid Waste (MSW) as fuel is common in countries like Canada, EU, Japan and Korea, but regulations do not yet permit in India.
- ❖ CPCB is actively engaged in plant level trials in respect of wastes viz. used tyres, refinery sludge, paint sludge, Effluent Treatment Plant (ETP) sludge and Toluene Di-Isocyanate (TDI) tar waste from petroleum industries and in formulation of guidelines for use of these wastes as fuel by cement industry.

Energy Management

The industry's average consumption in 2005-06 was 725 kcal/kg clinker thermal energy and 82 kWh/t cement electrical energy. It is expected that the industry's average thermal energy consumption by the end of Year 2011-12 will come down to about 710 kcal/kg clinker and the average electrical energy consumption will come down to 78 kWh/t cement.

The best thermal and electrical energy consumption presently achieved in India is 667 kcal/kg clinker and 68 kWh/t cement which are comparable to the best figures of 650 kcal/kg clinker and 65 kWh/t cement in a developed country like Japan.

The improvements in energy performance of cement plants in the recent past have been possible largely due to:

- Retrofitting and adoption of energy efficient equipment
- Better operational control and Optimization
- Upgradation of process control and instrumentation facilities
- Better monitoring and Management Information System
- Active participation of employees and their continued exposure in energy conservation efforts etc.

Conclusion:

The emissions from modern dry preheater / precalciner kilns seem generally to be slightly lower than emissions from wet kilns. A common practise in many countries today is to co-process waste and alternative raw materials in dry preheater kilns, thereby saving fossil fuel and virgin raw materials. One example illustrates this: a UNEP project measured emissions between 0.0001-0.018 ng TEQ/m³ from a dry preheater kiln in Thailand replacing parts of the fossil fuel with tyres and hazardous waste; the lowest concentration was found when the kiln was co-processing hazardous waste, 0.0002 ng TEQ/m³.

Websites:

- ❖ www.CemNet.com
- ❖ <http://www.cementindustry.co.uk>
- ❖ http://www.anpm.ro/Files/bref/BREF/ES_Cement_and_Lime_Manufacturing_Industries_EN.pdf

Publications:

- ❖ European Commission, 2001. *Integrated Pollution Prevention and Control (IPPC), Reference Document on Best Available Techniques (BREF) in the Cement and Lime Manufacturing Industries, December 2001.*
- ❖ European Commission, 2007. *Integrated Pollution Prevention and Control (IPPC), Reference Document on Best Available Techniques (BREF) in the Cement and Lime Manufacturing Industries.* Draft September 2007. Available at <http://eippcb.jrc.es>. [Accessed 5 August 2009]
- ❖ IPCC, 2006. *2006 IPCC Guidelines for National Greenhouse Gas Inventories.* Eggleston, H.S., Buendia, L., Miwa, K., Ngara, T. and Tanabe, K. (eds), National Greenhouse Gas Inventories Programme. IGES, Japan.
- ❖ Kakareka, 2008. *Personal communication.* Institute for problems of use of natural resources and ecology, Belarusian National Academy of Sciences, Minsk.
- ❖ Visschedijk, A.J.H., Pacyna, J., Pulles, T., Zandveld, P. and Denier van der Gon, H., 2004.
- ❖ 'Coordinated European Particulate Matter Emission Inventory Program (CEPMEIP)'. In: Dilara, P. *et. al* (eds), *Proceedings of the PM emission inventories scientific workshop, Lago Maggiore, Italy, 18 October 2004.* EUR 21302 EN, JRC, pp. 163–174.

REFERENCES

Documents

- **Ministry of Environment and Forest, GoI** - “Environment Impact Assessment Notification” S.O.1533 dated 14th September 2006.
- **Ministry of Environment and Forest, GoI** – “Environment Impact Assessment Notification 2006 – Amendment” S.O. 195 (E) dated 1st December, 2009.
- **Ministry of Environment and Forest, GoI** – Charter on Corporate Responsibility for Environment Protection Action Points for 17 Categories of Industries, CPCB, March 2003.
- **Larry W. Canter**, “Environmental Impact Assessment”, Second Edition, McGraw Hill, University of Oklahoma, 1997.
- **European Commission** - “Integrated Pollution Prevention and Control (IPPC)”, Reference Document on Best Available Techniques in the Cement and Lime Manufacturing Industries, December 2001.
- **European Cement Association** - “Best Available Techniques for the Cement Industry”, December 1999.
- **Egyptian Environmental Affairs Agency (EEAA)** - “Environmental Impact Assessment Guidelines for Cement Manufacturing Plants”, Ministry of State for Environmental Affairs, January 2005.
- **Environmental Protection Agency** - “BAT Guidance Note on Best Available Techniques for the Production of Cement and for the Production of Lime in a Kiln (1st Edition)”, An Ghníomhaireacht um Chaomhnu Comhshaoil, 2008.
- **International Finance Corporation** - “Environmental, Health and Safety Guidelines for Cement and Lime Manufacturing”, World Bank Group, April 30, 2007.
- **International Association for Impact Assessment** in Cooperation with Institute of Environmental Assessment, UK – “Principles of Environmental Impact Assessment Best Practice, 1996
- **World Bank Group** - “Cement Manufacturing, Pollution Prevention and Abatement Handbook”, Effective July 1998.
- **Central Pollution Control Board** - “Assessment of Utilization of Industrial Solid Wastes in Cement Manufacturing”, Programme Objective Series Probes/103/2006-2007.
- **Central Pollution Control Board** - “Environmental Guidelines for Prevention and Control of Fugitive Emissions from Cement Plants”,.
- **Natural Environmental Research Council** - “Cement Raw Materials - Mineral Profile”, British Geological Survey, November 2005.

- “Emission Estimation Technique Manual for Cement Manufacturing”, Version 2.1, National Pollutant Inventory, Department of the Environment, Water, Heritage and the Arts, Australian Government, April 2008.
- “Environmental Impact Assessment (EIA) Report on Cement Project of Lafarge Surma Cement (LSC) at Chhatak, Sunamgonj”, Final Report, Envirocare (Pvt) Limited, Dhaka, Bangladesh, August 1997.
- “Modelling a Cement Manufacturing Process to Study Possible Impacts of Alternative Fuels”, Ursula Kääntee, Ron Zevenhoven, Rainer Backman, Mikko Hupa, Energy Engineering and Environmental Protection, Helsinki University of Technology, Finland, June 2002.
- “Report on Life Cycle Assessment Study for Cement Sector”, prepared by National Council for Cement & Building Materials (NCBM) and submitted to MoEF.
- “The European Cement Industry, Background Assessment, For the IPTS BAT – Competitive Project”, February 2000.
- **Ecosmart India Ltd.**, - Report on Secondary Data Collection for Environmental Information Centre, submitted to Ministry of Environment and Forests, 28th March 2003

Websites

- <http://business.mapsofindia.com/cement/>
- <http://envfor.nic.in/divisions/iass/eia.htm>
- <http://siadipp.nic.in/publicat/cement.htm>
- <http://www.cpcb.nic.in/>
- <http://www.cembureau.be/>
- http://www.cement.org/basics/concretebasics_history.asp
- <http://www.cement.org/manufacture/>
- http://www.energytechpro.com/Demo-IC/Business_Sector/Industrial/Cement_Manufacturing.htm
- <http://www.energymanagertraining.com/cement/CementManufacturing.htm>
- <http://www.epa.gov/>
- <http://www.iaia.org>
- <http://www.understanding-cement.com/manufacturing.html>
- www.cementcorporation.co.in
- www.cmaindia.org



IL&FS Ecosmart Limited
Flat # 408, Saptagiri Towers
Begumpet
Hyderabad – 500 016
Ph: + 91 40 40163016
Fax: + 91 40 40032220