

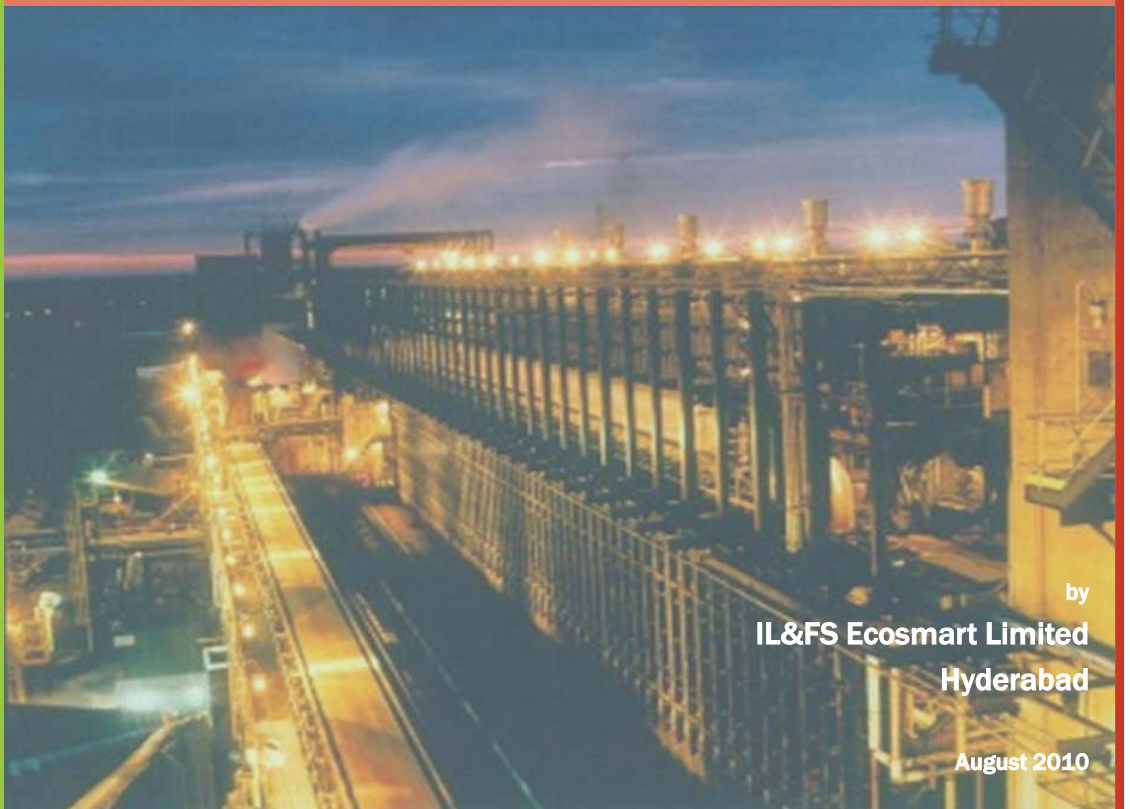

TECHNICAL EIA GUIDANCE MANUAL FOR COKE OVEN PLANTS

Prepared for
The Ministry of Environment and Forests
Government of India

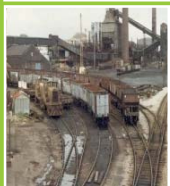

by
IL&FS Ecosmart Limited
Hyderabad

August 2010

PROJECT TEAM

Project Coordination Ministry of Environment & Forests	Dr. Nalini Bhat Advisor, Ministry of Environment and Forests Dr. T. Chandni Director, Ministry of Environment and Forests
Core Project Coordination Team IL&FS Environment	Mr. Mahesh Babu CEO Mr. N. Sateesh Babu Vice President & Project Director Mr. B.S.V. Pavan Gopal Manager –Technical Mr. Vijaya Krishna. D Senior Environmental Engineer Ms. Chaitanya Vangeti Assistant Manager Ms. Suman Benedicta Thomas Technical Writer
Resource Person	Mr. K.D. Choudhury Former GM (Environment), MECON
Expert Core & Peer Committee Chairman	Dr. V. Rajagopalan, IAS Additional Secretary Ministry of Chemicals & Fertilizers
Core Members	Dr. R. K. Garg Former Chairman, EIA Committee, Ministry of Environment and Forests Mr. Paritosh C. Tyagi Former Chairman, Central Pollution Control Board Prof. S.P. Gautam Chairman, Central Pollution Control Board Dr. Tapan Chakraborti Director, National Environmental Engineering Research Institute Mr. K. P. Nyati Former Head, Environmental Policy, Confederation of Indian Industry Dr. G.K. Pandey Former Advisor, Ministry of Environment and Forests Dr. Nalini Bhat Advisor, Ministry of Environment and Forests Dr. G.V. Subramaniam Advisor, Ministry of Environment and Forests Dr. B. Sengupta Former Member Secretary, Central Pollution Control Board Dr. R. C. Trivedi Former Scientist, Central Pollution Control Board
Peer Member	Prof. S.P. Mehrotra Director – National Metallurgical Laboratory
Member Convener	Mr. N. Sateesh Babu Project Director

TABLE OF CONTENTS

1. INTRODUCTION TO THE TECHNICAL EIA GUIDANCE MANUALS PROJECT	1-1
1.1 Purpose	1-2
1.2 Project Implementation.....	1-4
1.3 Additional Information	1-4
2. CONCEPTUAL FACETS OF EIA	2-1
2.1 Environment in EIA Context.....	2-1
2.2 Pollution Control Strategies.....	2-2
2.3 Tools for Preventive Environmental Management	2-2
2.3.1 Tools for assessment and analysis	2-3
2.3.2 Tools for action	2-5
2.3.3 Tools for communication	2-10
2.4 Objectives of EIA	2-10
2.5 Types of EIA	2-11
2.6 Basic EIA Principles.....	2-12
2.7 Project Cycle.....	2-13
2.8 Environmental Impacts.....	2-14
2.8.1 Direct impacts.....	2-14
2.8.2 Indirect impacts	2-15
2.8.3 Cumulative impacts.....	2-15
2.8.4 Induced impact	2-15
2.9 Significance of Impacts	2-16
2.9.1 Criteria/methodology to determine the significance of the identified impacts. 2-17	
3. ABOUT COKE OVEN PLANTS INCLUDING PROCESS AND POLLUTION CONTROL TECHNOLOGIES	3-1
3.1 Introduction	3-1
3.1.1 History and evolution of coking industry in India.....	3-1
3.2 Scientific Aspects and Industrial Processes.....	3-2
3.2.1 Coke Production	3-3
3.2.2 Coke properties.....	3-6
3.2.3 Technological interventions for improving quality of coke	3-9
3.2.4 Industrial processes in the context of environmental pollution.....	3-14
3.2.5 Specific energy consumption factors.....	3-25
3.2.6 Qualitative and quantitative analysis of rejects	3-26
3.2.7 Exposure Pathway	3-26
3.3 Technological Aspects.....	3-28
3.3.1 Cleaner technologies	3-28
3.3.2 Pollution control technologies.....	3-31
3.3.3 Best operating practices.....	3-33
3.4 Summary of Applicable National Regulatory Requirements	3-34

3.4.1	General description of major statutes	3-34
3.4.2	General standards for discharge of environmental pollutants	3-34
3.4.3	Industry specific standards	3-34
4.	OPERATIONAL ASPECTS OF EIA	4-1
4.1	Coverage of Coke oven plant under the Purview of Notification.....	4-1
4.2	Screening	4-5
4.2.1	Applicable conditions for Category B projects	4-5
4.2.2	Criteria for classification of Category B1 and B2 projects	4-5
4.2.3	Application for prior environmental clearance.....	4-6
4.2.4	Siting guidelines	4-6
4.3	Scoping for EIA Studies	4-7
4.3.1	Pre-feasibility report.....	4-9
4.3.2	Guidance for providing information in Form 1	4-10
4.3.3	Identification of appropriate valued environmental components	4-10
4.3.4	Methods for identification of impacts	4-11
4.3.5	Testing the Significance of Impacts	4-16
4.3.6	Terms of reference for EIA studies	4-16
4.4	Environmental Impact Assessment.....	4-21
4.4.1	EIA team.....	4-22
4.4.2	Baseline quality of the environment.....	4-23
4.4.3	Impact prediction tools	4-26
4.4.4	Significance of the impacts	4-26
4.5	Social Impact Assessment	4-27
4.6	Risk Assessment	4-29
4.6.1	Storage & Handling of hazardous materials.....	4-33
4.6.2	Hazard identification	4-33
4.6.3	Hazard assessment and evaluation	4-33
4.6.4	Disaster management plan.....	4-35
4.7	Mitigation Measures	4-38
4.7.1	Important considerations for mitigation methods.....	4-39
4.7.2	Hierarchy of elements of mitigation plan	4-40
4.7.3	Typical mitigation measures.....	4-41
4.8	Environmental Management Plan.....	4-44
4.9	Reporting	4-45
4.10	Public Consultation.....	4-47
4.11	Appraisal.....	4-50
4.12	Decision Making.....	4-51
4.13	Post-clearance Monitoring Protocol	4-53
5.	STAKEHOLDERS' ROLES AND RESPONSIBILITIES	5-1
5.1	SEIAA	5-3
5.2	EAC and SEAC	5-6

LIST OF TABLES

Table 3-1: Coke Quality Specifications	3-8
Table 3-2: Comparison of Ovens with different Heights and Useful Volumes	3-12
Table 3-3: Composition of Raw Coke Oven Gas	3-19
Table 3-4: Specific Emission of harmful substances in atmosphere from by-product recovery type coke oven plants	3-26
Table 3-5: Exposure Pathways.....	3-27
Table 3-6: Coke Oven Plants (By Product Recovery Type).....	3-35
Table 3-7: Coke Oven - Wastewater Discharge Standards	3-36
Table 4-1: Advantages and Disadvantages of Impact Identification Methods	4-11
Table 4-2: Impact Matrix	4-13
Table 4-3: List of Important Physical Environment Components and Indicators of EBM.....	4-24
Table 4-4: Choice of Models for Impact Predictions: Risk Assessment.....	4-31
Table 4-5: Typical Mitigation Measures.....	4-42
Table 4-6: Structure of EIA Report.....	4-45
Table 5-1: Roles and Responsibilities of Stakeholders Involved in Prior Environmental Clearance	5-1
Table 5-2: Organization-specific Functions.....	5-2
Table 5-3: SEIAA: Eligibility Criteria for Chairperson/ Members/ Secretary	5-5
Table 5-4: EAC/SEAC: Eligibility Criteria for Chairperson / Members / Secretary	5-8

LIST OF FIGURES

Figure 2-1: Inclusive Components of Sustainable Development.....	2-1
Figure 2-2: Types of Impacts.....	2-14
Figure 2-3: Cumulative Impact.....	2-15
Figure 3-1: By Product Recovery Type Coke Production Process.....	3-3
Figure 3-2: Top Charged Coke Oven Battery with By-Product Recovery (Red Hot Coke Being Charged in Quench Car in inset).....	3-4
Figure 3-3: Coke Side of a By-Product Coke Oven Battery.....	3-4
Figure 3-4: Incandescent coke in the oven waiting to be "pushed".....	3-5
Figure 3-5: Heat Recovery Technology Process.....	3-6
Figure 3-6: Blast Furnace Operating Zones and Coke Behavior.....	3-7
Figure 3-7: Development of Oven Chamber Volumes.....	3-11
Figure 3-8: CSQ-Quench System.....	3-13
Figure 3-9: Typical Flow Diagram of a Top Charged Coke Oven Plant Showing Emission Sources .	3-15
Figure 3-10: General Process Flow Chart - Stamp Charge Coke Oven Battery with other facilities	3-16
Figure 3-11: Typical scheme of a COG treatment plant with recovery of by-products.....	3-20
Figure 3-12: Schematic diagram of possible water flows in a coke oven plant.....	3-24
Figure 4-1: Prior Environmental Clearance Process for Activities Falling Under Category A.....	4-3
Figure 4-2: Prior Environmental Clearance Process for Activities Falling Under Category B.....	4-4
Figure 4-3: Approach for EIA Study.....	4-22
Figure 4-4: Risk Assessment – Conceptual Framework.....	4-31
Figure 4-5: Comprehensive Risk Assessment - At a Glance.....	4-32
Figure 4-6: Elements of Mitigation.....	4-40

ACRONYMS

AAQ	Ambient Air Quality
ADA	Anthraquinone Disulphonic Acid
ASK	Ammoniumsulphide Kreislaufwascher
B/C	Benefits Cost Ratio
BAT	Best Available Technology
BF	Blast Furnaces
BOD	Biological Oxygen Demand
BOQ	Bill of Quantities
BOT	Build Operate Transfer
CCA	Conventional Cost Accounting
CDQ	Coke Dry Quenching
CER	Corporate Environmental Reports
CEAA	Canadian Environmental Assessment Agency
CFE	Consent for Establishment
COG	Coke Oven Gas
COS	Carbon Oxisulphide
CPCB	Central Pollution Control Board
CREP	Corporate Responsibility for Environmental Protection
CRZ	Coastal Regulatory Zone
CS ₂	Carbon Disulphide
CSQ	Coke Stabilization Quenching
CSR	Coke Strength after Reaction
DfE	Design for Environment
DMP	Disaster Management Plan
EAC	Expert Appraisal Committee
ECI	Environmental Condition Indicators
EcE	Economic-cum-Environmental
EIA	Environmental Impact Assessment
EIS	Environmental Information System
EMA	Environmental Management Accounting
EMP	Environmental Management Plan
EMS	Environmental Management System
EPI	Environmental Performance Indicators
EPR	Extended Producers Responsibilities
ES	Environmental Statements
FCA	Full Cost Assessment

FCI	Fertilizer Corporation of India
GHG	Green House Gas
H ₂ S	Hydrogen Sulphide
HAZOP	Hazard and Operability Studies
HPALA	High Pressure Ammonia Liquor Aspiration System
HTL	High Tide Level
IL&FS	Infrastructure Leasing and Financial Services
IVI	Importance Value Index
ISO	International Standard Organization
JICA	Japan International Cooperation Agency
LCA	Life Cycle Assessment
LDAR	Leak Detection and Repair
LTL	Low Tide Level
MCA	Maximum Credible Accident
MoEF	Ministry of Environment & Forests
NAQM	National Air Quality Monitoring
NGO	Non-Government Organizations
O&M	Operation and Maintenance
OECD	Organization for Economic Co-operation and Development
PBCC	Partial Briquetting of Coal Charge
PDU	Process Development Unit
PLD	Percent Leaking Doors
PLL	Percent Leaking Lids
PLO	Percent Leaking Off takes
PM	Particulate Matter
PPA	Participatory Poverty Assessment
PRA	Participatory Rural Appraisal
QA/QC	Quality Assurance/Quality Control
QRA	Quantitative Risk Assessment
SEA	Strategic Environmental Assessment
SEAC	State Level Expert Appraisal Committee
SEIAA	State Level Environment Impact Assessment Authority
SEZ	Special Economic Zone
SIA	Social Impact Assessment
SME	Small and Medium Scale Enterprises
SPCB	State Pollution Control Board
SPM	Suspended Particulate Matter
SRC	Solvent Refining of Coal

LIST OF ANNEXURES

Annexure I

A Compilation of Legal Instruments

Annexure II

General Standards for Discharge of Environmental Pollutants as per CPCB

Annexure III

Form 1 (Application Form for Obtaining EIA Clearance)

Annexure IV

Critically Polluted Industrial Areas and Clusters / Potential Impact Zone

Annexure V

Pre-feasibility Report: Points for Possible Coverage

Annexure VI

Types of Monitoring and Network Design Considerations

Annexure VII

Guidance for Assessment of Baseline Components and Attributes

Annexure VIII

Sources of Secondary Data

Annexure IX

Impact Prediction Tools

Annexure X

Form through which the State Government/Administration of the Union Territories Submit Nominations for SEIAA and SEAC for the Consideration and Notification by the Central Government.

Annexure XI

Composition of EAC/SEAC

Annexure XII

Best Practices & Latest Technologies available and reference

Mahesh Babu
Chief Executive Officer

Acknowledgement

The Notification issued on the prior environmental clearance process by the Ministry of Environment and Forests (MoEF) on September 14, 2006 delegated substantial powers to the State Level Environment Impact Assessment Authorities (SEIAA) to grant environmental clearance for certain categories of developmental activities/projects. It was felt that proper guidance to the stakeholders would enhance appreciation of environmental impacts of proposed projects and possible mitigation measures. Further, such a guidance would also help ensure that decision making authorities across different States and Union Territories could adopt similar considerations and norms with due weightage for site-specific considerations.

We feel privileged to be part of the interventions being spearheaded by Sh. Jairam Ramesh, Hon'ble Minister, MoEF, Government of India, to mainstream environmental considerations in the decision making process. IL&FS Ecosmart as part of this important initiative, prepared Technical EIA Guidance Manuals for 27 identified development activities. In view of the diversity of 27 developmental activities entrusted to IL&FS Ecosmart Ltd., in consultation with the MoEF, an expert Peer and Core Committee was constituted to review and finalize each of the draft Manuals. The Manuals prepared by IL&FS were technically reviewed and up-dated by the respective sector-specific expert resource persons.

The Manuals designed by the Expert Committee have benefitted from the advise and feedback received from MoEF. The Manuals are designed to provide readers with an in-depth understanding of the environmental clearance mechanism, developmental activity specific environmental impacts with possible mitigation measures, environmentally compliant manufacturing/ production processes and pollution control technologies, etc.

IL&FS Ecosmart hopes that these Manuals are a step forward to realize the MoEF's desired objective of enhancing functional efficiency and effectiveness in the environmental clearance process. We hope the stakeholders will find the Manuals useful.

We take this opportunity to convey our appreciation to the MoEF team under the leadership of Mr. J.M. Mauskar, Additional Secretary, for the technical inputs, guidance and support extended throughout the project period for successful completion of the project. The technical guidance and support extended by the Expert Peer and Core Committee under the Chairmanship of Dr. V. Rajagopalan, former Chairman, Central Pollution Control Board and inputs of the sector-specific resource persons are gratefully acknowledged.

(Mahesh Babu)

15th November 2010



22nd December 2010

FOREWORD

The Ministry of Environment & Forests (MOEF) introduced the Environmental Impact Assessment (EIA) Notification 2006 on 14th September 2006, which not only reengineered the entire environment clearance (EC) process specified under the EIA Notification 1994, but also introduced a number of new developmental sectors which would require prior environmental clearance. The EIA Notification 2006 has notified a list of 39 developmental sectors which have been further categorised as A or B based on their capacity and likely environmental impacts. Category B projects have been further categorised as B1 and B2. The EIA Notification 2006 has further introduced a system of screening, scoping and appraisal and for the setting up of Environment Impact Assessment Authority (EIAA) at the Central level and State Level Environment Impact Assessment Authorities (SEIAAs) to grant environmental clearances at the Central and State level respectively. The Ministry of Environment & Forests is the Environment Impact Assessment Authority at the Central level and 25 State Level Environment Impact Assessment Authorities (SEIAAS) have been set up in the various States/UTs. The EIA Notification 2006 also stipulates the constitution of a multi-disciplinary Expert Appraisal Committee (EAC) at the Centre and State level Expert Appraisal Committees (SEACs) at State/UT Level for appraisal of Category A or B projects respectively and to recommend grant/rejection of environmental clearance to each project/activities falling under the various sectors to the EIAA/SEIAAs respectively.

Although the process of obtaining environmental clearance consisting of Screening, Scoping and Appraisal and for undertaking public consultation including the process of conduct of Public Hearing has been elaborated under the EIA Notification 2006, the Notification itself provides for bringing out guidelines from time to time on the EIA Notification 2006 and the EC process with a view to bringing clarity on the EC process for expediting environmental clearance. This need was further reinforced after the constitution of SEIAAs and SEACs in various States, who were assigned the task for the first time and for addressing the concerns of standardization of the quality of appraisal and in reducing inconsistencies between SEACs/SEIAAs in granting ECs for similar projects in different States.

The Technical Guidance Manual of "Coke oven Plants" sector describes types of process and pollution control technologies, operational aspects of EIA with model TOR of that Sector, technological options with cleaner production and waste minimization techniques, monitoring

of environmental quality, post clearance monitoring protocol, related regulations, and procedure of obtaining EC if linked to other clearances for e.g., CRZ, etc.

Coke oven plant emissions or rejects (gaseous, solid & hazardous as well as liquid effluents) can cause damage to human health, aquatic and terrestrial ecology as well as material due to various exposure routes (pathways). For example adverse effects of coke oven plants on human health can derive from the direct impact of noxious gases on the organism and/or their indirect impact via the food chain and changes in the environment. Injurious heavy metals (e.g., lead, mercury and cadmium) can enter the food chain and, hence, the human organism by way of drinking water and vegetable and animal products. India's industrial competitiveness and environmental future depends on Industries such as Coke oven Plants adopting energy and resource efficient technologies. Recycling and reuse of materials is critical.

To keep pace with changing technologies and needs of sustainable development, the manual would require regular updating in the future. The manual will be available on the MoEF website and we would appreciate receiving responses from stakeholders for further improvements.

I congratulate the entire team of IL&FS Ecosmart Ltd., experts from the sector who were involved in the preparation of the Manuals, Chairman and members of the Core and Peer Committees of various sectors and various Resource Persons whose inputs were indeed valuable in the preparation and finalization of the Manuals.



(Jairam Ramesh)

1. INTRODUCTION TO THE TECHNICAL EIA GUIDANCE MANUALS PROJECT

Environmental Impact Assessment (EIA) is a process of identifying, predicting, evaluating and mitigating the biophysical, social, and other relevant effects of development proposals prior to major decisions being taken and commitments made. These studies integrate the environmental concerns of developmental activities into the process of decision-making.

EIA has emerged as one of the successful policy innovations of the 20th Century in the process of ensuring sustained development. Today, EIA is formalized as a regulatory tool in more than 100 countries for effective integration of environmental concerns in the economic development process. The EIA process in India was made mandatory and was also given a legislative status through a Notification issued by the Ministry of Environment and Forests (MoEF) in January 1994. The Notification, however, covered only a few selected industrial developmental activities. While there are subsequent amendments, the Notification issued on September 14, 2006 supersedes all the earlier Notifications, and has brought out structural changes in the clearance mechanism.

The basic tenets of this EIA Notification could be summarized into the following:

- Pollution potential as the basis for prior environmental clearance instead of investment criteria; and
- Decentralization of clearing powers to the State/Union Territory (UT) level Authorities for certain developmental activities to make the prior environmental clearance process quicker, transparent and effective.

Devolution of the power to grant clearances at the state level for certain category of the developmental activities / projects is a step forward to fulfill the basic tenets of the re-engineering *i.e.*, quicker, transparent and effective process but many issues come on its way of functional efficiency. These issues could be in technical and operational domains as listed below:

Technical issues

- Ensuring level playing ground to avoid arbitrariness in the decision-making process
- Classification of projects which do not require public hearing and detailed EIA (Category B2)
- Variations in drawing Terms of Reference (ToR) of EIA studies for a given developmental activity across the States/UTs
- Varying developmental-activity-specific expertise requirement for conducting EIA studies and their appraisal
- Availability of adequate sectoral experts and variations in competency levels
- Inadequate data verification, cross checking tools and supporting institutional framework

- Meeting time targets without compromising with the quality of assessments/ reviews
- Varying knowledge and skill levels of regulators, consultants and experts
- Newly added developmental activities for prior environmental clearance, *etc.*

Operational issues

- State level /UT level EIA Authorities (SEIAA/UTEIAA) are formulated for the first time and many are functioning
- Varying roles and responsibilities of involved organizations
- Varying supporting institutional strengths across the States/UTs
- Varying manpower availability, *etc.*

1.1 Purpose

The purpose of developing the sector-specific technical EIA guidance manuals (TGM) is to provide clear and concise information on EIA to all the stakeholders *i.e.*, the project proponent, the consultant, the reviewer, and the public. The TGMs are organized to cover following:

Chapter 1 (Introduction): This chapter provides a brief introduction on the EIA, basic tenets of EIA Notification, technical & operational issues in the process of clearance, purpose of the TGMs, project implementation process and additional information.

Chapter 2 (Conceptual facets of an EIA): Provides an overall understanding to the conceptual aspects of control of pollution and EIA for the developmental projects. This basic understanding would set the readers at same level of understanding for proper interpretations and boundaries for identifying the environmental interactions of the developmental projects and their significance for taking mitigative measures. This chapter covers the discussion on environment in EIA context *i.e.* sustainable development, pollution control strategies, preventive environmental management tools, Objectives of EIA, types and basic principles of EIA, project cycle for coke oven industry, understanding on type of environmental impacts and the criteria for the significance analysis.

Chapter 3 (The coke oven industry): The purpose of this chapter is to provide the reader precise information on all the relevant aspects of the industry, which is essential to realize the likely interaction of such developmental activities on the receiving environment. Besides, this Chapter gives a holistic understanding on the sources of pollution and the opportunities of the source control.

The specific coverage which provides precise information on the industry include (i) introduction to the coke oven industry in India, (ii) Scientific Aspects and Industrial Processes - Coke Production, Coke properties, Technological interventions for improving quality of coke, Industrial processes in the context of environmental pollution, Specific energy consumption factors, Qualitative and quantitative analysis of rejects, Exposure Pathway, (iii) Technological aspects - cleaner and pollution control technologies, better operating practices and (vi) the summary of applicable national regulation for this developmental activity.

Chapter 4 (Operational aspects): The purpose of this chapter is to facilitate the stakeholders to extend clear guidance on coverage of legislative requirements, sequence

of procedures for obtaining the EIA clearance and each step-wise provisions and considerations.

The coverage of the Chapter include provisions in the EIA Notification regarding coke oven industry, screening (criteria for categorization of B1 and B2, siting guidelines, *etc.*), scoping (pre-feasibility report, guidance for filling form 1, identification of valued environmental components, identification of impacts, *etc.*), arriving at terms of reference for EIA studies, impact assessment studies (EIA team, assessment of baseline quality of environment, impact prediction tools, significance of impacts), social impact assessment, risk assessment considerations, typical mitigation measures, designing considerations for environmental management plan, structure of EIA report for incorporation of study findings, process of public consultation, project appraisal, decision making process and post-clearance monitoring protocol.

Chapter 5 (Roles and responsibilities of various organizations involved in the process of prior environmental clearance): The purpose of this Chapter is to brief the stakeholders on the institutional mechanism and roles & responsibilities of the stakeholders involved in the process of prior environmental clearance. The Coverage of the Chapter include (i) roles and responsibilities of the stakeholders, (ii) organization specific functions, (iii) constitution, composition and decision making process of SEIAA and (iv) EAC & SEAC and (v) other conditions which may be considered.

For any given industry, each topic listed above could alone be the subject of a lengthy volume. However, in order to produce a manageable document, this project focuses on providing summary information for each topic. This format provides the reader with a synopsis of each issue. Text within each section was researched from many sources, and was usually condensed from more detailed sources pertaining to specific topics.

The contents of the document are designed with a view to facilitate in addressing of the relevant technical and operational issues as mentioned in the earlier section. Besides, the TGM facilitates various stakeholders involved in the EIA clearance process *i.e.*,

- Project proponents will be fully aware of the procedures, common ToR for EIA studies, timelines, monitoring needs, *etc.*, in order to plan the projects/studies appropriately.
- Consultants across India will gain similar understanding about a given sector, and also the procedure for EIA studies, so that the quality of the EIA reports gets improved and streamlined
- Reviewers across the States/UTs will have the same understanding about an industrial sector and would able to draw a benchmark in establishing the significant impacts for the purpose of prescribing the ToR for EIA studies and also in the process of review and appraisal.
- Public who are concerned about new or expansion projects, use this manual to get a basic idea about the manufacturing/production details, rejects/wastes from the operations, choice of cleaner/control technologies, regulatory requirements, likely environmental and social concerns, mitigation measures, *etc.*, in order to seek clarifications appropriately in the process of public consultation. The procedural clarity in the document will further strengthen them to understand the stages involved in clearance and roles and responsibilities of various organizations.
- In addition, these manuals would substantially ease the pressure on reviewers at the scoping stage and would bring in functional efficiency at the central and state levels.

1.2 Project Implementation

The Ministry of Environment & Forests (MoEF), Government of India took up the task of developing sector-specific technical EIA guidance manuals for all the developmental activities listed in the re-engineered EIA Notification. The Infrastructure Leasing and Financial Services Ecosmart Limited (IL&FS Ecosmart), has been entrusted with the task of developing these manuals for 27 industrial and related sectors. Coke oven plants are one of these sectors, for which this manual is prepared.

The ability to design comprehensive EIA studies for specific industries depends on the knowledge of several interrelated topics. Therefore, it requires expert inputs from multiple dimensions *i.e.*, administrative, project management, technical, scientific, social, economic, risk *etc.*, in order to comprehensively analyze the issues of concern and to draw logical interpretations. Thus, Ecosmart has designed a well-composed implementation framework to factor inputs of the experts and stakeholders in the process of finalization of these manuals.

The process of manual preparation involved collection & collation of the secondary available information, technical review by sectoral resource persons and critical review & finalization by a competent Expert Committee composed of core and sectoral peer members.

The MoEF appreciates the efforts of Ecosmart, Expert Core and Peer Committee, resource persons and all those who have directly and indirectly contributed to this Manual.

1.3 Additional Information

This TGM is brought out by the MoEF to provide clarity to all the stakeholders involved in the 'Prior Environmental Clearance' process. As such, the contents and clarifications given in this document do not withstand in case of a conflict with the statutory provisions of the Notifications and Executive Orders issued by the MoEF from time-to-time.

TGMs are not regulatory documents. Instead these are the tools designed to assist in successful completion of an EIA.

For the purpose of this project, the key elements considered under TGMs are: conceptual aspects of EIA; developmental activity-specific information; operational aspects; and roles and responsibilities of involved stakeholders.

This manual is prepared considering the Notification issued on September 14, 2006 and latest amendments as on 1st December 2009. For recent updates, if any, may please refer the website of the MoEF, Government of India *i.e.*, <http://moef.nic.in/index.php>

2.

CONCEPTUAL FACETS OF EIA

It is an imperative requirement to understand the basic concepts concerned to the pollution control and the environmental impact assessment in an overall objective of the sustainable development. This Chapter highlights the pollution control strategies and their tools besides the objectives, types & principles of EIA, type of impacts their significance analysis, in order to provide consistent understanding to the reader before assessing the development of activity-specific environmental concerns in Chapter 3 and identification & prediction of significant impacts in order to design mitigation measures as detailed in Chapter 4.

2.1 Environment in EIA Context

“Environment” in EIA context mainly focuses, but is not limited to physical, chemical, biological, geological, social, economical, and aesthetic dimensions along with their complex interactions, which affect individuals, communities and ultimately determines their forms, character, relationship, and survival. In EIA context, ‘effect’ and ‘impact’ can often be used interchangeably. However, ‘impact’ is considered as a value judgment of the significance of an effect.

Sustainable development is built on three basic premises *i.e.*, economic growth, ecological balance and social progress. Economic growth achieved in a way that does not consider the environmental concerns, will not be sustainable in the long run. Therefore, sustainable development needs careful integration of environmental, economic, and social needs in order to achieve both an increased standard of living in short term, and a net gain or equilibrium among human, natural, and economic resources to support future generations in the long term.

“It is necessary to understand the links between environment and development in order to make choices for development that will be economically efficient, socially equitable and responsible, as well as environmentally sound.”

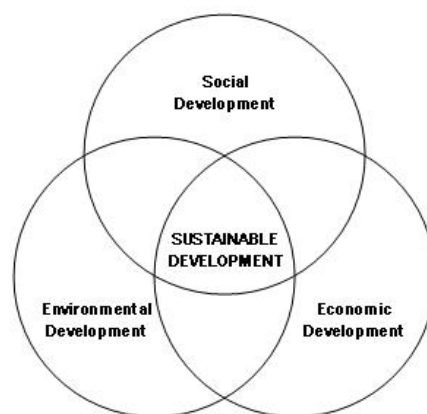

Figure 2-1: Inclusive Components of Sustainable Development

2.2 Pollution Control Strategies

Pollution control strategies can be broadly categorized into preventive and reactive. The reactive strategy refers to the steps that may be applied once the wastes are generated or contamination of the receiving environment takes place. The control technology or a combination of technologies to minimize the impact due to the process rejects/wastes varies with quantity and characteristics, desired control efficiency and economics.

Many combinations of techniques could be adopted for treatment of a specific waste or the contaminated receiving environment, but are often judged based on techno-economic feasibility. Therefore, the best alternative is to take all possible steps to avoid pollution it self. This preventive approach refers to a hierarchy that involves i) prevention & reduction; ii) recycling and re-use; iii) treatment; and iv) disposal, respectively.

Therefore, there is a need to shift the emphasis from the reactive to preventive strategy *i.e.*, to promote preventive environmental management. Preventive environmental management tools may be grouped into management based tools, process based tools and product based tools, which are given below:

Management Based Tools	Process Based Tools	Product Based Tools
Environmental Management System (EMS)	Environmental Technology Assessment	Industrial Ecology
Environmental Performance Evaluation	Toxic Use Reduction	Extended Producers Responsibility
Environmental Audits	Best Operating Practices	Eco-labeling
Environmental Reporting and Communication	Environmentally Best Practice	Design for Environment
Total Cost Accounting	Best Available Technology (BAT)	Life Cycle Assessment (LCA)
Law and Policy	Waste Minimization	
Trade and Environment	Pollution Prevention	
Environmental Economics	Cleaner Production	
	4-R Concept	
	Cleaner Technology	
	Eco-efficiency	

2.3 Tools for Preventive Environmental Management

The tools for preventive environmental management can be broadly classified into following three groups.

- Tools for assessment and analysis - risk assessment, life cycle assessment, total cost assessment, environmental audit / statement, environmental benchmarking, environmental indicators
- Tools for action - environmental policy, market based economic instruments, innovative funding mechanism, EMS and ISO certification, total environmental quality movement, eco-labeling, cleaner production, eco-efficiency, industrial ecosystem or metabolism, voluntary agreements
- Tools for communication - state of environment, corporate environmental reporting

Specific tools under each group are discussed precisely in next sections.

2.3.1 Tools for assessment and analysis

2.3.1.1 Risk assessment

Risk is associated with the frequency of failure and consequence effect. Predicting such situations and evaluation of risk is essential to take appropriate preventive measures. The major concern of the assessment is to identify the activities falling in a matrix of high & low frequencies at which the failures occur and the degree of its impact. The high frequency, low impact activities can be managed by regular maintenance *i.e.*, LDAR (Leak detection and repair) programmes. Whereas, the low frequency, high impact activities are of major concern (accidents) in terms of risk assessment. As the frequency is low, often the required precautions are not realized or maintained. However, the risk assessment identify the areas of major concerns, which require additional preventive measures; likely consequence distances considering domino effects, which will give the possible casualties and ecological loss in case of accidents. These magnitudes demand the attention for preventive and disaster management plans (DMP). Thus is an essential tool to ensure safety of operations.

2.3.1.2 Life cycle assessment

A broader approach followed to deal with environmental impacts during manufacturing is called LCA. This approach recognizes that environmental concerns are associated with every step of the processing w.r.t. manufacturing of products and also examines environmental impacts of the product at all stages of project life cycle. LCA includes product design, development, manufacturing, packaging, distribution, usage and disposal. LCA is concerned with reducing environmental impacts at all the stages and considering the total picture rather than just one stage of the production process.

By availing this concept, firms can minimize costs incurred on the environmental conservation throughout the project life cycle.

2.3.1.3 Total cost assessment

Total Cost Assessment (TCA) is an enhanced financial analysis tool that is used to assess the profitability of alternative courses of action ex. raw material substitution to reduce the costs of managing the wastes generated by process; an energy retrofit to reduce the costs of energy consumption. This is particularly relevant for pollution prevention options, because of their nature, often produce financial savings that are overlooked in conventional financial analysis, either because they are misallocated, uncertain, hard to quantify, or occur more than three to five years after the initial investment. TCA involves all of the relevant costs and savings associated with an option so that it can compete for scarce capital resources fairly, on a level playing field. The assessments are often beneficial in respect of the following:

- Identification of costly resource inefficiencies
- Financial analysis of environmental activities/projects such as investment in cleaner technologies
- Prioritization of environmental activities/projects
- Evaluation of product mix and product pricing
- Bench marking against the performance of other processes or against the competitors

A comparison of cost assessments is given below:

- Conventional cost accounting (CCA): Direct and indirect financial costs+ Recognized contingent costs
- Total Cost Assessment (TCA): A broader range of direct, indirect, contingent and less quantifiable costs
- Full Cost assessment (FCA): TCA + External social costs borne by society

2.3.1.4 Environmental audit/statement

The key objectives of an environmental audit includes compliance verification, problem identification, environmental impact measurement, environmental performance measurement, conforming effectiveness of EMS, providing a database for corrective actions and future actions, developing companies environmental strategy, communication and formulating environmental policy.

The MoEF, Government of India issued Notification on ‘*Environmental Statements*’ (ES) in April, 1992 and further amended in April 1993 – As per the Notification, the industries are required to submit environmental statements to the respective State Pollution Control Board (SPCB). ES is a pro-active tool for self-examination of the industry itself to reduce/minimize pollution by adopting process modifications, recycling and reusing of the resources. The regular submission of ES will indicate the systematic improvement in environmental pollution control being achieved by the industry. In other way, the specific points in ES may be used as environmental performance indicators for relative comparison, implementation and to promote better practices.

2.3.1.5 Environmental benchmarking

Environmental performance and operational indicators could be used to navigate, manage and communicate the significant aspects and give enough evidence of good environmental house keeping. Besides prescribing standards, an insight to identify the performance indicators and prescribing schedule for systematic improvement in performance of these indicators will yield better results.

Relative indicators may be identified for different industrial sectors and be integrated in the companies and organizations to monitor and manage the different environmental aspects of the company, to benchmark and compare two or more companies from the same sector. These could cover the water consumption, wastewater generation, energy consumption, solid/hazardous waste generation, chemical consumption *etc.*, per tonne of final product. Once these bench marks are developed, the industries which are below them may be guided and enforced to reach the level and those which are better than the bench mark may be encouraged further by giving incentives *etc.*

2.3.1.6 Environmental indicators

Indicators can be classified in to environmental performance indicators (EPI) and environmental condition indicators (ECI). The EPIs can be further divided into two categories *i.e.*, operational performance indicators and management performance indicators.

The operational performance indicators are related to the process and other operational activities of the organization, these would typically address the issue of raw material consumption, energy consumption, water consumption in the organization, the quantities of wastewater generated, other solid wastes generated, emission from the organization *etc.*

Management performance indicators are related to the management efforts to influence the environmental performance of the organizations operations.

The environmental condition indicators provide information about the environment. These indicators provide information about the local, regional, national or global condition of the environment. This information helps the organization to understand the environmental impacts of its activities and thus helps in taking decisions to improve the environmental performance.

Indicators basically used to evaluate environmental performance against the set standards and thus indicate the direction in which to proceed. Selection of type of indicators for a firm or project depends upon its relevance, clarity and realistic cost of collection and its development.

2.3.2 Tools for action

2.3.2.1 Environmental policy

An environmental policy is a statement of the organization's overall aim and principles of action w.r.t the environment, including compliance with all relevant regulatory requirements. It is a key tool in communicating the environmental priorities of the organizations to all its employees. To ensure organization's commitment towards a formulated environmental policy, it is essential for the top management to be involved in the process of formulating the policy and setting priorities. Therefore, the first step is to get the commitment from the higher levels of management. The organization should then conduct an initial environmental review and draft an environmental policy. This draft should be discussed and approved by the board of directors and finally the approved environmental policy statement must be communicated internally among all its employees and must also be made available to the public.

The MoEF, Government of India published the National Environment Policy, thus the individual firms while making their environmental policies may like to refer the national environment policy for synchronization.

2.3.2.2 Market-based economic instruments

Market based instruments are regulations that encourage behavior through market signals rather than through explicit directives regarding pollution control levels. These policy instruments such as tradable permits, pollution charge *etc.* are often described as harnessing market forces. Market based instruments can be categorized into the following four major categories which are discussed below.

- **Pollution charge:** Charge system will assess a fee or tax on the amount of pollution a firm or source generates. It is worthwhile for the firm to reduce emissions to the point, where its marginal abatement costs is equal to the tax rate. Thus firms control pollution to different degrees *i.e.* High cost controllers – less; low-cost controllers- more. The charge system encourages the industries to further reduce the pollutants. The collected charges can form a fund for restoration of the environment. Another form of pollution charge is a deposit refund system, where, consumers pay a surcharge when purchasing a potentially polluting product, and receive a refund on return of the product after useful life span at appropriate centers. The concept of

extended producers' responsibility brought in to avoid accumulation of dangerous products in the environment.

- **Tradable permits:** Under this system, firms that achieve the emission levels below their allotted level may sell the surplus permits. Similarly, the firms, which are required to spend more to attain the required degree of treatment/allotted levels, can purchase permits from others at lower costs and may be benefited.
- **Market barrier reductions:** Three known market barrier reduction types are as follows:
 - Market creation: Measures that facilitate the voluntary exchange of water rights and thus promote more efficient allocation of scarce water supplies.
 - Liability concerns: Encourage firms to consider potential environmental damages of their decisions
 - Information programmes: Eco-labeling and energy- efficiency product labeling requirements
- **Government subsidy reduction:** Subsidies are the mirror images of taxes and, in theory, can provide incentive to address environmental problems. However, it has been reported that the subsidies encourage economically inefficient and environmentally unsound practices, and often leads to market distortions due to differences in the area. However, these are important to sustain the expansion of production, in the national interests. In such cases, the subsidy may be comparable to the net social benefit.
- In India, the environmental laws are in the criminal domain, thus negotiation on the offense is restricted. However, there are instances, in which Bank Guarantees are imposed to drive the commitment for compliance. Besides, certain tax exemptions and subsidies are extended to promote pollution control in the country.

2.3.2.3 Innovative funding mechanism

There are many forums under which the fund is made available for the issues which are of global/regional concern *i.e.*, climate change, Basal convention and further fund sources are being explored for the Persistent Organic Pollutants Convention. Besides the global funding mechanism, there needs to be localized alternative mechanisms for boosting the investment in environmental pollution control. For example, in India the Government has established mechanism to fund the common effluent treatment plants, which are specifically serving the small and medium scale enterprises *i.e.*, 25% share by the State Government, matching grants from the Central Government and surety for 25% soft loan. It means that the industries need to invest only 25% initially, thus encouraging voluntary compliance.

There are some more options *i.e.*, if the pollution tax/charge is imposed on the residual pollution being caused by the industries, municipalities *etc.*, fund will automatically be generated, which in turn, can be utilized for funding the environmental improvement programmes. The emerging concept of build-operate-transfer (BOT) is an encouraging development, where there is a possibility to generate revenue by application of advanced technologies. There are many opportunities which can be explored. However, what is required is the paradigm shift and focused efforts.

2.3.2.4 EMS and ISO certification

EMS is that part of the overall management system, which includes the organizational structure, responsibilities, practices, procedures, process and resources for determining and implementing the forms of overall aims, principles of action w.r.t the environment. It encompasses the totality of organizational, administrative and policy provisions to be taken by a firm to control its environmental influences. Common elements of an EMS are the identification of the environmental impacts and legal obligations, the development of a plan for management & improvement, the assignment of the responsibilities and monitoring of the performance.

2.3.2.5 Total environmental quality movement (TEQM)

Quality is regarded as

- A product attribute that had to be set at an acceptable level and balanced against the cost
- Something delivered by technical systems engineered by experts rather than the organization as a whole
- Assured primarily through the findings and correction of mistakes at the end of the production process

One expression of the total environment quality movement (TEQM) is a system of control called Kaizen. The principles of Kaizen are:

- Goal must be continuous improvement of quality instead of acceptable quality
- Responsibility of the quality shall be shared by all members of an organization
- Efforts should be focused on improving the whole process and design of the products

With some modifications, TEQM approach can be applied in the improvement of corporate environmental performance in both process and product areas.

2.3.2.6 Eco-labeling

It is known as the practice of supplying information on the environmental characteristics of a product or service to the general public. These labeling schemes can be grouped in to three types:

- Type I: Multiple criteria base; third party (Govt. or non-commercial private organizations) programme claims overall environmental preferability.
- Type II: Specific attribute of a product; often issued by a company/industrial association
- Type III: Agreed set of indices; provides quantified information; self declaration

Among the above, Type I are more reliable because they are established by a third party and considers the environmental impacts of a product from cradle to grave. However, the labeling program will only be effective if linked with complementary program of consumer education and up on restriction of umbrella claims by the producers.

2.3.2.7 Cleaner production

Cleaner production is one of the tools, which has lot of bearing on environmental pollution control. It is also seen that the approach is changing with time *i.e.*, dumping-to-control-to-recycle-to-prevention. Promotion of cleaner production principles involves an insight into the production processes not only to get desired yield but also to optimize on raw material consumption *i.e.*, resource conservation and implications of the waste treatment and disposal.

2.3.2.8 4-R concept

The concept endorses utilization of the wastes as a by-product to the extent possible *i.e.*, Re-cycle, Recover, Reuse, Recharge. Recycling refers to using the wastes/by-products in the process again as a raw material to maximize the production. Recovery refers to engineering means such as solvent extraction, distillation, precipitation *etc.* to separate the useful constituents of the wastes, so that these recovered materials can be used. Re-use refers to the utilization of waste from one process as a raw material to other. Recharging is an option in which the natural systems are used for renovation of waste for further use.

2.3.2.9 Eco-efficiency

The World Business Council on sustainable development (WBCSD) defines eco-efficiency as “the delivery of competitively priced goods and services that satisfy human needs and bring quality of life, while progressively reducing ecological impacts and resource intensity throughout the life cycle, to a level at least in line with earth’s carrying capacity”. The business implements the eco-efficiency on four levels *i.e.* optimized processes, recycling of wastes, eco-innovation and new services. Fussler (1995) defined six dimensions of eco efficiency, which are given below to understand/examine the system.

- **Mass:** There is an opportunity to significantly reduce mass burdens (raw materials, fuels, utilities consumed during the life cycle)
- **Reduce Energy Use:** The opportunity is to redesign the product or its use to provide significant energy savings
- **Reduce Environmental Toxins:** This is concern to the environmental quality and human health. The opportunity here is to significantly control the dispersion of toxic elements.
- **Recycle when Practical:** Designing for recyclability is important
- **Working with Mother Nature:** Materials are borrowed and returned to the nature without negatively affecting the balance of the ecosystem.
- **Make it Last Longer:** It relates to useful life and functions of products. Increasing the functionality of products also increase their eco efficiency.

The competitiveness among the companies and long-term survival will continue and the successful implementation of eco efficiency will contribute to their success. There is a need to shift towards responsible consumerism equal to the efficiency gains made by corporations – doing more with less.

2.3.2.10 Industrial ecosystem or metabolism

Eco-industrial development is a new paradigm for achieving excellence in business and environmental performance. It opens up innovative avenues for managing business and conducting economic development by creating linkages among local ‘resources’, including businesses, non-profit groups, governments, unions, educational institutions, and communities can creatively foster the dynamic and responsible growth. Antiquated business strategies based on isolated enterprises are no longer responsive enough to market, environmental and community requirements.

Sustainable eco-industrial development looks at development, business and environment systematically, and attempts to stretch the boundaries of current practice. On one level, it is as directly practical as making the right connections between the wastes and resources needed for production and at the other level, it is a whole new way of thinking about doing business and interacting with communities. At the most basic level, it is each organization seeking higher performance within itself. However, most eco-industrial activity is moving to a new level by increasing the inter connections between the companies.

Strategic partnership, networked manufacturing and performed supplier arrangements are all the examples of ways used by the businesses to ensure growth, contain costs and to reach out for new opportunities.

For most businesses, the two essentials for success are the responsive markets and access to cost-effective, quality resources for producing products or delivering services. In absence of these two factors, virtually, every other incentive becomes a minor consideration.

Transportation issues are important at two levels, the ability to get goods to market in an expeditious way is essential to success in this day of just in time inventories. The use of least impact transportation with due consideration of speed and cost supports business success and addresses concerned in the community.

Eco-industrial development works because it consciously mixes a range of targeted strategies shaped to the contours of the local community, most importantly, it works because the communities wants nothing less than the best possible in or near their neighborhoods. For companies, it provides a path towards significantly higher operating results and positive market presence. For our environment, it provides great hope that the waste will be transformed in to valued product and that the stewardship will be a joint pledge of both businesses and communities.

2.3.2.11 Voluntary agreements

Voluntary environmental agreements among the industries, government, public representatives, NGOs and other concerned towards attaining certain future demands of the environment are reported to be successful. Such agreements may be used as a tool where Government would like to make the standards stringent in future (phase-wise-stringent). These may be used when conditions are temporary and requires replacing timely. Also these may be used as supplementary/ complimentary in implementation of the regulation. The agreements may include:

- Target objectives (emission limit values/standards)
- Performance objectives (operating procedures)

- R&D activities – Government and industry may have agreement to establish better control technologies.
- Monitoring & reporting of the agreement conditions by other agents (NGOs, public participants, civil authority *etc.*)

In India, the MoEF has organized such programme, popularly known as the corporate responsibility for environment protection (CREP) considering identified 17 categories of high pollution potential industrial sectors. Publication in this regard is available with Central Pollution Control Board (CPCB).

2.3.3 Tools for communication

2.3.3.1 State of environment

The Government of India brought out the state of environment report for entire country and similar reports available for many of the states. These reports are published at regular intervals to record trends and to identify the required interventions at various levels. These reports consider the internationally accepted DPSIR framework for the presentation of the information. DPSIR refers to

- D – Driving forces – causes of concern *i.e.* industries, transportation *etc.*
- P – Pressures – pollutants emanating from driving forces *i.e.* emission
- S – State – quality of environment *i.e.* air, water & soil quality
- I – Impact – Impact on health, eco-system, materials, biodiversity, economic damage *etc.*
- R – Responses – action for cleaner production, policies (including standards/guidelines), targets *etc.*

Environment reports including the above elements gives a comprehensive picture of specific target area in order to take appropriate measures for improvement. Such reports capture the concerns, which could be considered in EIAs.

2.3.3.2 Corporate environmental reporting

Corporate environmental reports (CERs) are only one form of environmental reporting defined as publicly available, stand alone reports, issued voluntarily by the industries on their environmental activities. CER is a means to environmental improvement and greater accountability, not an end in itself.

Three categories of environmental disclosure are:

- Involuntary Disclosure: Without its permission and against its will (env. Campaign, press *etc.*)
- Mandatory Disclosure: As required by law
- Voluntary Disclosure: Disclosure of information on a voluntary basis

2.4 Objectives of EIA

Objectives of EIA include the following:

- To ensure environmental considerations are explicitly addressed and incorporated into the development decision-making process;
- To anticipate and avoid, minimize or offset the adverse significant biophysical, social and other relevant effects of development proposals;
- To protect the productivity and capacity of natural systems and the ecological processes which maintain their functions; and
- To promote development that is sustainable and optimizes resource use and management opportunities.

2.5 Types of EIA

Environmental assessments could be classified into four types *i.e.* strategic environmental assessment, regional EIA, sectoral EIA and project level EIA. These are precisely discussed below:

Strategic environmental assessment

Strategic Environmental Assessment (SEA) refers to systematic analysis of the environmental effects of development policies, plans, programmes and other proposed strategic actions. SEA represents a proactive approach to integrate environmental considerations into the higher levels of decision-making – beyond the project level, when major alternatives are still open.

Regional EIA

EIA in the context of regional planning integrates environmental concerns into development planning for a geographic region, normally at the sub-country level. Such an approach is referred to as the economic-cum-environmental (EcE) development planning. This approach facilitates adequate integration of economic development with management of renewable natural resources within the carrying capacity limitation to achieve sustainable development. It fulfils the need for macro-level environmental integration, which the project-oriented EIA is unable to address effectively. Regional EIA addresses the environmental impacts of regional development plans and thus, the context for project-level EIA of the subsequent projects, within the region. In addition, if environmental effects are considered at regional level, then cumulative environmental effects of all the projects within the region can be accounted.

Sectoral EIA

Instead of project-level-EIA, an EIA should take place in the context of regional and sectoral level planning. Once sectoral level development plans have the integrated sectoral environmental concerns addressed, the scope of project-level EIA will be quite minimal. Sectoral EIA helps in addressing specific environmental problems that may be encountered in planning and implementing sectoral development projects.

Project level EIA

Project level EIA refers to the developmental activity in isolation and the impacts that it exerts on the receiving environment. Thus, it may not effectively integrate the cumulative effects of the development in a region.

From the above discussion, it is clear that EIA shall be integrated at all the levels *i.e.* strategic, regional, sectoral and the project level. Whereas, the strategic EIA is a structural change in the way the things are evaluated for decision-making, the regional EIA refers to substantial information processing and drawing complex inferences. The project-level EIA is relatively simple and reaches to meaningful conclusions. Therefore in India, largely, the project-level EIA studies are taking place and are being considered. However, in the re-engineered Notification, provisions have been incorporated for giving a single clearance for the entire industrial estate for *e.g.*, Leather parks, pharma cities *etc.*, which is a step towards the regional approach.

As we progress and the resource planning concepts emerge in our decision-making process, the integration of overall regional issues will become part of the impact assessment studies.

2.6 Basic EIA Principles

By integrating the environmental impacts of the development activities and their mitigation early in the project planning cycle, the benefits of EIA could be realized in all stages of a project, from exploration and planning, through construction, operations, decommissioning, and beyond site closure.

A properly-conducted-EIA also lessens conflicts by promoting community participation, informing decision makers, and also helps in laying the base for environmentally sound projects. An EIA should meet at least three core values:

- Integrity: The EIA process should be fair, objective, unbiased and balanced
- Utility: The EIA process should provide balanced, credible information for decision-making
- Sustainability: The EIA process should result in environmental safeguards

Ideally an EIA process should be:

- Purposive - should inform decision makers and result in appropriate levels of environmental protection and community well-being.
- Rigorous - should apply 'best practicable' science, employing methodologies and techniques appropriate to address the problems being investigated.
- Practical - should result in providing information and acceptable and implementable solutions for problems faced by proponents.
- Relevant - should provide sufficient, reliable and usable information for development planning and decision making.
- Cost-effective - should impose the minimum cost burdens in terms of time and finance on proponents and participants consistent with meeting accepted requirements and objectives of EIA.
- Efficient - should achieve the objectives of EIA within the limits of available information, time, resources and methodology.
- Focused - should concentrate on significant environmental effects and key issues; *i.e.*, the matters that need to be taken into account in making decisions.

- Adaptive - should be adjusted to the realities, issues and circumstances of the proposals under review without compromising the integrity of the process, and be iterative, incorporating lessons learned throughout the project life cycle.
- Participative - should provide appropriate opportunities to inform and involve the interested and affected publics, and their inputs and concerns should be addressed explicitly in the documentation and decision making.
- Inter-disciplinary - should ensure that the appropriate techniques and experts in the relevant bio-physical and socio-economic disciplines are employed, including use of traditional knowledge as relevant.
- Credible - should be carried out with professionalism, rigor, fairness, objectivity, impartiality and balance, and be subject to independent checks and verification.
- Integrated- should address the interrelationships of social, economic and biophysical aspects.
- Transparent - should have clear, easily understood requirements for EIA content; ensure public access to information; identify the factors that are to be taken into account in decision making; and acknowledge limitations and difficulties.
- Systematic - should result in full consideration of all relevant information on the affected environment, of proposed alternatives and their impacts, and of the measures necessary to monitor and investigate residual effects.

2.7 Project Cycle

The generic project cycle including that of the coke oven plants has six main stages:

- 1) Project concept
- 2) Pre-feasibility
- 3) Feasibility
- 4) Design and engineering
- 5) Implementation
- 6) Monitoring and evaluation

It is important to consider the environmental factors on an equal basis with technical and economic factors throughout the project planning, assessment and implementation phases. Environmental considerations should be introduced at the earliest in the project cycle and must be an integral part of the project pre-feasibility and feasibility stage. If the environmental considerations are given due respect in the site selection process by the project proponent, the subsequent stages of the environmental clearance process would get simplified and would also facilitate easy compliance to the mitigation measures throughout the project life cycle.

A project's feasibility study should include a detailed assessment of significant impacts, and the EIA include a detailed prediction and quantification of impacts and delineation of Environmental Management Plan (EMP). Findings of the EIA study should preferably be incorporated in the project design stage so that the project as well as the site alternatives is studied and necessary changes, if required, are incorporated in the project design stage. This practice will also help the management in assessing the negative impacts and in designing cost-effective remedial measures. In general, EIA enhances the project quality and improves the project planning process.

2.8 Environmental Impacts

Environmental impacts resulting from proposed actions can be grouped into following categories:

- Beneficial or detrimental
- Naturally reversible or irreversible
- Repairable via management practices or irreparable
- Short term or long term
- Temporary or continuous
- Occurring during construction phase or operational phase
- Local, regional, national or global
- Accidental or planned (recognized before hand)
- Direct (primary) or Indirect (secondary)
- Cumulative or single

The category of impact as stated above, and the significance will facilitate the Expert Appraisal Committee (EAC)/State Level EAC (SEAC) to take a look at the ToR for EIA studies, as well as, in decision making process about the developmental activity.

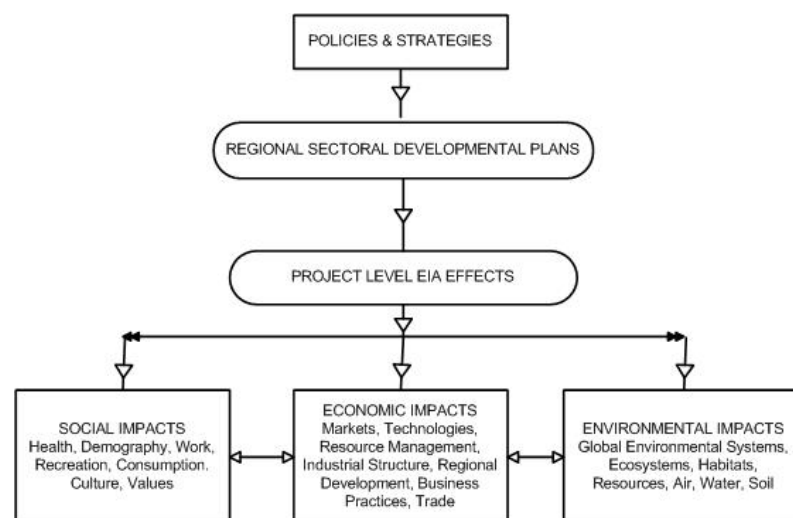

Figure 2-2: Types of Impacts

The nature of impacts could fall within three broad classifications *i.e.*, direct, indirect and cumulative, based on the characteristics of impacts. The assessment of direct, indirect and cumulative impacts should not be considered in isolation or considered as separate stages in the EIA. Ideally, the assessment of such impacts should form an integral part of all stages of the EIA. The TGM does not recommend a single method to assess the types of impacts, but suggests a practical framework/approach that can be adapted and combined to suit a particular project and the nature of impacts.

2.8.1 Direct impacts

Direct impacts occur through direct interaction of an activity with an environmental, social, or economic component. For example, a discharge of Coke oven plant or an effluent from the Phenolic Effluent Treatment Plant, normally a BOD plant, into a river may lead to a decline in water quality in terms of high biochemical oxygen demand (BOD) or dissolved oxygen (DO) or rise of water toxins.

2.8.2 Indirect impacts

Indirect impacts on the environment are those which are not a direct result of the project, often produced away from or as a result of a complex impact pathway. The indirect impacts are also known as secondary or even tertiary level impacts. For example, the H₂S contained in the CO gas upon combustion will get converted to SO₂ and ambient air SO₂ rise due to stack emissions may deposit on land as SO₄ and cause acidic soils. Another example of indirect impact is the decline in water quality due to rise in temperature of water bodies receiving cooling water discharge from the nearby industry. This in turn, may lead to a secondary indirect impact on aquatic flora in that water body and may further cause reduction in fish population. Reduction in fishing harvests, affecting the incomes of fishermen is a third level impact. Such impacts are characterized as socio-economic (third level) impacts. The indirect impacts may also include growth-inducing impacts and other effects related to induced changes to the pattern of land use or additional road network, population density or growth rate. In the process, air, water and other natural systems including the ecosystem may also be affected.

2.8.3 Cumulative impacts

Cumulative impact consists of an impact that is created as a result of the combination of the project evaluated in the EIA together with other projects in the same vicinity, causing related impacts. These impacts occur when the incremental impact of the project is combined with the cumulative effects of other past, present and reasonably foreseeable future projects. Figure 2-3 depicts the same. Respective EAC may exercise their discretion on a case-by-case basis for considering the cumulative impacts.

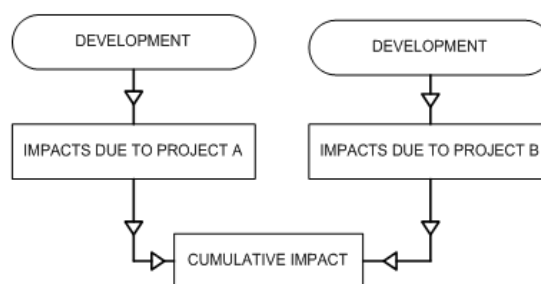

Figure 2-3: Cumulative Impact

2.8.4 Induced impact

The cumulative impacts can be due to induced actions of projects and activities that may occur if the action under assessment is implemented such as growth-inducing impacts and other effects related to induced changes to the pattern of future land use or additional road network, population density or growth rate (e.g., excess growth may be induced in the zone of influence around a coke oven plant, and in the process causing additional effects on air, water and other natural ecosystems). Induced actions may not be officially announced or be part of any official plan. Increase in workforce and nearby communities contributes to this effect.

They usually have no direct relationship with the action under assessment, and represent the growth-inducing potential of an action. New roads leading from those constructed for a project, increased recreational activities (e.g., hunting, fishing), and construction of new service facilities are examples of induced actions.

However, the cumulative impacts due to induced development or third level or even secondary indirect impacts are difficult to be quantified. Because of higher levels of uncertainties, these impacts cannot normally be assessed over a long time horizon. An EIA practitioner usually can only guess as to what such induced impacts may be and the possible extent of their implications on the environmental factors. Respective EAC may exercise their discretion on a case-by-case basis for considering the induced impacts by specifying it very early at ToR stage.

2.9 Significance of Impacts

This TGM establishes the significance of impacts first and proceeds to delineate the associated mitigation measures. So the significance here reflects the “worst-case scenario” before mitigation is applied, and therefore provides an understanding of what may happen if mitigation fails or is not as effective as predicted. For establishing significance of different impacts, understanding the responses and interaction of the environmental system is essential. Hence, the impact interactions and pathways are to be understood and established first. Such an understanding will help in the assessment process to quantify the impact as accurately as possible. Complex interactions, particularly in the case of certain indirect or cumulative impacts, may give rise to non-linear responses which are often difficult to understand and therefore their significance is difficult to assess. It is hence understood that indirect or cumulative impacts are more complex than the direct impacts. Currently the impact assessments are limited to direct impacts. In case mitigation measures are delineated before determining significance of the effect, the significance represents the residual effects.

However, the ultimate objective of an EIA is to achieve sustainable development. The development process shall invariably cause some residual impacts even after implementing an EMP effectively. Environmentalists today are faced with a vital, not-easy-to-answer question—“What is the tolerable level of environmental impact within the sustainable development framework?” As such, it has been recognized that every ecosystem has a threshold for absorbing deterioration and a certain capacity for self-regeneration. These thresholds based on concept of carrying capacity are as follows:

- Waste emissions from a project should be within the assimilative capacity of the local environment to absorb without unacceptable degradation of its future waste absorptive capacity or other important services.
- Harvest rates of renewable resource inputs should be within the regenerative capacity of the natural system that generates them; depletion rates of non-renewable inputs should be equal to the rate at which renewable substitutes are developed by human invention and investment.

The aim of this model is to curb over-consumption and unacceptable environmental degradation. But because of limitation in available scientific basis, this definition provides only general guidelines for determining the sustainable use of inputs and outputs. To establish the level of significance for each identified impact, a three-stage analysis may be referred:

- First, an impact is qualified as being either negative or positive.
- Second, the nature of impacts such as direct, indirect, or cumulative is determined using the impact network
- Third, a scale is used to determine the severity of the effect; for example, an impact is of low, medium, or high significance.

It is not sufficient to simply state the significance of the effect. This determination must be justified, coherent and documented, notably by a determination methodology, which must be described in the methodology section of the report. There are many recognized methodologies to determine the significance of effects.

2.9.1 **Criteria/methodology to determine the significance of the identified impacts**

The criteria can be determined by answering some questions regarding the factors affecting the significance. This will help the EIA stake-holders, the practitioner in particular, to determine the significance of the identified impacts eventually. Typical examples of such factors include the following:

- Exceedance of a threshold: significance may increase if a threshold is exceeded. *e.g.*, particulate matter emissions exceed the permissible threshold.
- Effectiveness of mitigation: significance may increase as the effectiveness of mitigation measures decreases. *e.g.*, control technologies, which may not assure consistent compliance to the requirements.
- Size of study area: significance may increase as the zone of effects increases.
- Incremental contribution of effects from action under review: significance may increase as the relative contribution of an action increases.
- Relative contribution of effects of other actions: significance may decrease as the significance of nearby larger actions increase.
- Relative rarity of species: significance may increase as species become increasingly rare or threatened.
- Significance of local effects: significance may increase as the significance of local effects is high.
- Magnitude of change relative to natural background variability: significance may decrease if effects are within natural assimilative capacity or variability.
- Creation of induced actions: significance may increase as induced activities also highly significant.
- Degree of existing disturbance: significance may increase if the surrounding environment is pristine.

For determining significance of impacts, it is important to remember that secondary and higher order effects can also occur as a result of a primary interaction between a project activity and the local environment. Wherever a primary effect is identified, the practitioner should always think if secondary or tertiary effects on other aspects of the environment could also arise.

The EIA should also consider the effects that could arise from the project due to induced developments, which take place as a consequence of the project. For *e.g.*, Population density and associated infrastructure and jobs for people attracted to the area by the project. It also requires consideration of cumulative effects that could arise from a combination of the effects due to other projects with those of other existing or planned developments in the surrounding area. So the necessity to formulate a qualitative checklist is suggested to test significance, in general.

3.

ABOUT COKE OVEN PLANTS INCLUDING PROCESS AND POLLUTION CONTROL TECHNOLOGIES

3.1 Introduction

Coke is produced from metallurgical grade coals and is an essential part of integrated steelmaking, because it provides the carbon to remove the oxygen from iron ore and the heat to produce molten iron in the blast furnace. Due to its strength and porous nature, coke is treated as an important contributor in the formation of the permeable bed required for the optimization of blast furnace performance. Coke making represents more than 50% of an integrated steel making's total energy use.

The two types of coke manufacturing technologies, which form an integral part of integrated iron and steel plant for commercial use are:

- Coke making through by-product recovery
- Coke making through non-recovery/heat recovery

3.1.1 History and evolution of coking industry in India

In India, building of coke oven batteries was initiated in the beginning of this century, but the major thrust came when batteries were built in fifties based on erstwhile USSR, UK and German designs as part of steel plants. As of now, about 3000 ovens are in operation/construction in coke oven plants.

Coke is basically a solid residue from the destructive distillation of coal at high temperatures (1100°C) in an oxygen deficient atmosphere and is a complex process involving several steps. The present day coking scenario across the world is a result of series of developments that have taken place since the latter half of 19th century. The evolution of the present day coke oven from the beehive oven is a result of continuous effort to optimize the coking process and introduction of innovative ideas to improve quality of coke, control of pollution and conservation of energy. Developmental efforts towards higher oven capacity include increase of height and width of the oven structures and improvement of silica brick quality.

By the year 2011-12, the world coking coal requirement will be about 433 metric tonnes (MT) in which India's requirement is estimated to be about 54 MT (12.5%). Import of low ash coking coal in the year 2007-08 is about 21.50 MT.

An analysis of coke making technologies – past and present makes it clear that technology development has taken place in the following three parallel paths with specific objectives:

- Emergence of new technologies *e.g.* stamp charging, preheating, selective crushing of coal, partial briquetting of coal, SRC (solvent refining of coal) with a view to conserve scarce coking coals and to improve productivity in some cases.
- Optimization of specific throughput capacity of oven and incorporation of innovative designs with a view to minimise number of pushing/charging operations, more of mechanization and automation thereby improving the overall working atmosphere of coke ovens.
- Introduction of energy conservation such as dry coke cooling technology and pollution control measures thereby making the coke manufacturing technologies more cost-effective and less polluting.

Several modern technologies have already made their entry into Indian coke oven industry. A 7 metre (m) tall coke oven battery was commissioned in 1987 and PBCC (Partial Briquetting of Coal Charge) in June 1990, in Bhilai Steel Plant. TISCO has adopted stamp charging technology & their battery 7 utilizing this technology went into operation in January, 1989. VSP coke oven battery with 7m tall ovens was commissioned in September 1989 with coke dry cooling facilities for the first time in the country. India's first selective crushing unit with pneumatic classifier was also introduced at VSP. Some of the facilities are under various stages of implementation in Indian coke oven plants.

Other technologies *e.g.* solvent refining of coal, formed coke manufacture and others are still under developmental stage and yet to be implemented in India. However, such innovative measures *e.g.*, mechanization, automation, emission control *etc.* are yet to find their impact in full strength in the existing plants. The constraints in this regard include retro-fitting in existing units, lack of awareness, resource constraints and non-availability of the technology indigenously. However, during recent rebuilding of coke ovens and planning of new installations, these facilities are being explored for incorporation.

Reasons for poor performance

Major portion of the coke comes from coke ovens installed in steel industry. To improve overall performance and quality of operation, suitable technologies should be adopted/absorbed from time-to-time in coke area. To assess the requirement of adoption/absorption of particular technology, it is necessary to carryout in-depth studies on the effects of various factors influencing the performance of coking industries. Poor quality and high ash content of Indian coking coal, inconsistent linkage of coal to coke making units, increased number of component in the blend and poor coal stock particularly in monsoon season, have put the coking industry under tremendous pressure. The ash level in coal charge has increased from 17-18% in 60's to 22-24% at present. This has increased ash level in coke to around 28-30%. Socio-economic pressures and industrial unrest along with various operational problems have affected the life of coke ovens in India.

3.2 Scientific Aspects and Industrial Processes

As discussed above coke making process involves carbonization of coal to high temperatures (1100°C) in an oxygen deficient atmosphere in order to concentrate the carbon. The commercial coke making process are a) By-product coke making and b) Non-recovery/heat recovery coke making. These two processes are described in this section.

3.2.1 Coke Production

3.2.1.1 By-product recovery type

In by-product recovery type coke making (Figure 3-1), coke and coke by-products including coke oven gas are produced by pyrolysis (heating in the absence of air) of suitable grade of coal (Figure 3-2). The process also includes processing of coke oven gas to remove tar, ammonia (usually recovered as ammonium sulphate), phenol, naphthalene, light oil, and sulphur before the gas is used as a fuel for heating in the ovens/reheating furnaces.

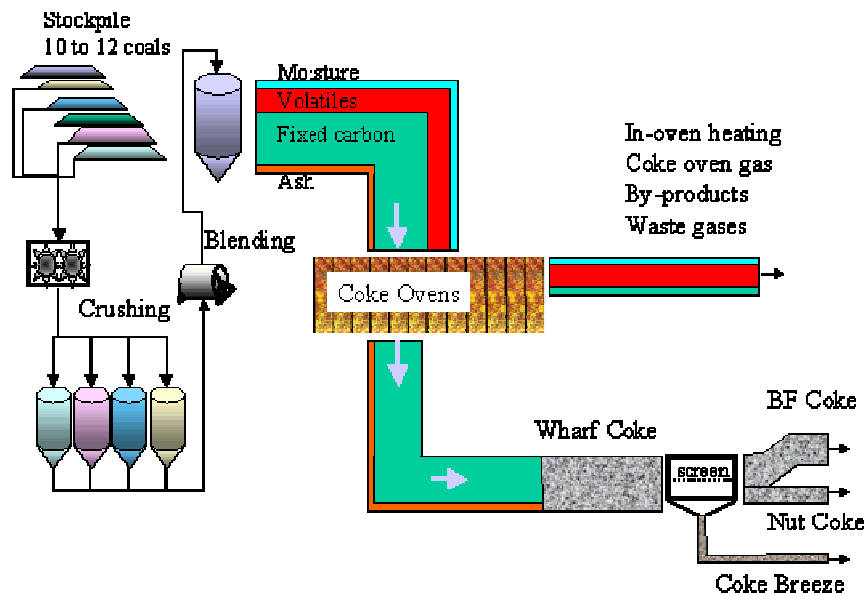

Figure 3-1: By Product Recovery Type Coke Production Process

The entire coke making operation is comprised of the following steps:

- i. Before carbonization, the selected coals are blended, pulverized and oiled/ moistured for proper bulk density control.
- ii. The blended coal is charged into a number of slot type ovens wherein each oven shares a common heating flue with the adjacent oven. This is applicable to both top charge and stamped charge coke ovens.
- iii. Coal is carbonized in a reducing atmosphere and the off gas is collected and sent to by-product plant where various by-products are recovered.
- iv. The off-gases so collected and treated are used as an energy source elsewhere in the steel production process, increasing overall energy efficiency.

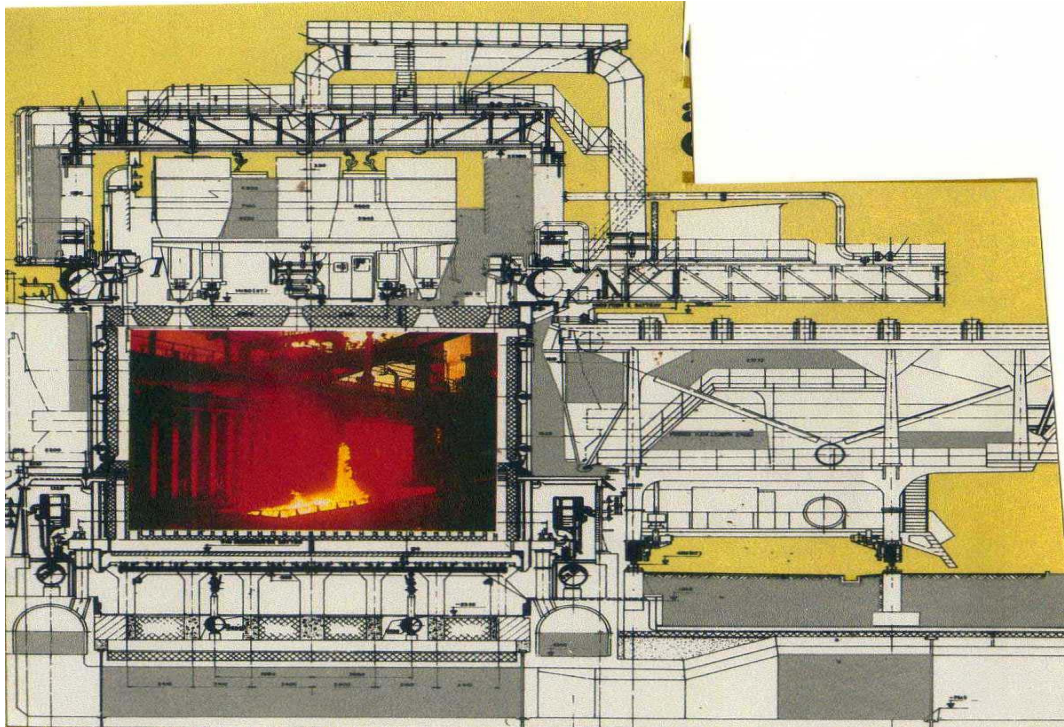

Figure 3-2: Top Charged Coke Oven Battery with By-Product Recovery (Red Hot Coke Being Charged in Quench Car in inset)

The majority of coke produced in India comes from wet-charge by-product coke oven batteries (Figure 3-3).



Figure 3-3: Coke Side of a By-Product Coke Oven Battery

The coal-to-coke transformation takes place as follows:

- The heat is transferred from the heated brick walls into the coal charge. From about 375°C to 475°C, the coal decomposes to form plastic layers near each wall.

- At about 475°C to 600°C, there is a marked evolution of tar, and aromatic hydrocarbon compounds, followed by resolidification of the plastic mass into semi-coke.
- At 600°C to 1100°C, the coke stabilisation phase begins. This is characterised by contraction of coke mass, structural development of coke and final hydrogen evolution.
- During the plastic stage, the plastic layers move from each wall towards the center of the oven trapping the liberated gas and creating in gas pressure build-up, which is transferred to the heating wall. Once, the plastic layers meet at the center of the oven, the entire mass becomes carbonized (Figure 3-4).
- The incandescent coke mass is pushed from the oven and is wet or dry quenched prior to its shipment to the blast furnace.



Figure 3-4: Incandescent coke in the oven waiting to be "pushed"

3.2.1.2 Non-recovery/heat recovery coke making

In non-recovery coke plants, originally referred to as beehive ovens, the coal is carbonized in large oven chambers (Figure 3-5). The carbonization process takes place from the top by radiant heat transfer and from the bottom by conduction of heat through the sole floor. The primary air for combustion is introduced into the oven chambers through several ports located above the charge level in pusher and coke side doors of the oven. Partially combusted gases exit the top chamber through 'down-comer' passages in the oven wall and enter the sole flue thereby heating the sole floor of the oven.

The combusted gases are collected in a common tunnel and exit via a stack, which creates a natural draft in the oven. Since the by-products are not recovered, the process is called 'non-recovery coke making'. In India, the waste gases are normally cleaned of dust only leaving SO₂ to be released. This is better controlled by providing a wet flue gas desulphurization, which can clean the gas of both dust as well as SO₂. In order to recover heat from the flue gases, waste heat recovery boilers are used which convert the excess heat into steam for power generation. Hence the process is also called 'heat recovery coke making'.

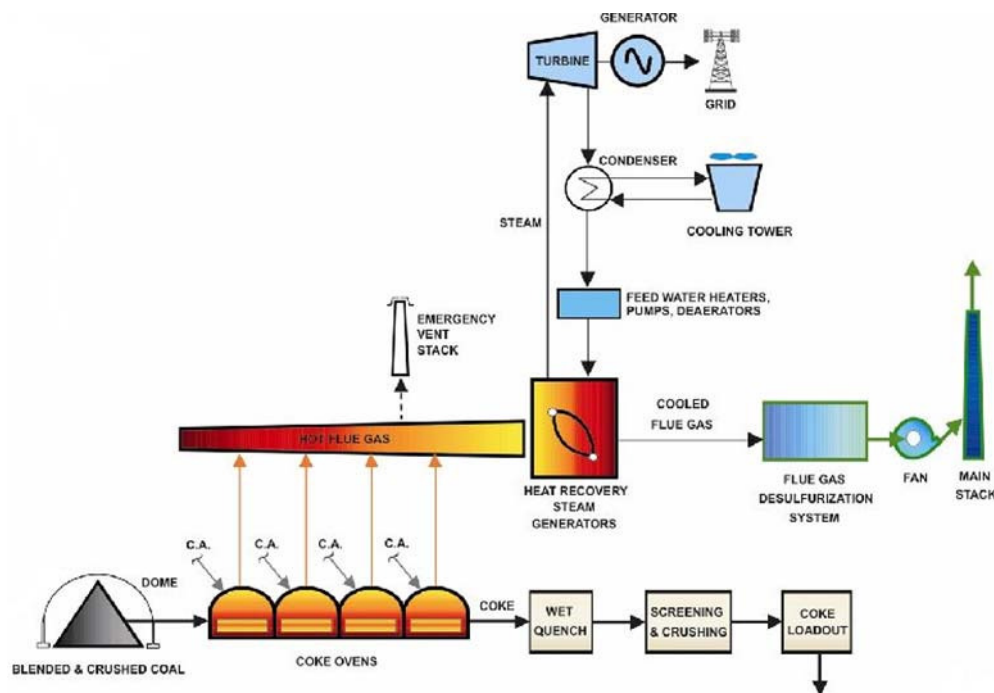

Figure 3-5: Heat Recovery Technology Process

The coke making process can be sub-divided in the following operations:

- Coal Preparation
 - Unloading of coal
 - Coal storage
 - Blending of coals of various grades
 - Coal crushing/screening
 - Coal transport to coal towers
- Coke Oven Battery
 - Coal charging (top charge/stamp charge)
 - Battery under fire and coking
- Coke Sorting
 - Coke pushing (on railroad car - quenching car)
 - Coke quenching
 - Coke crushing/screening and transport to destination plant
- Collection and cleaning of Coke Oven Gas (COG) and recovery of by-products from recovery ovens/recovery of waste gas from non-recovery ovens,
- Distribution of COG to waste heat recovery boilers, and
- Treatment of phenolic wastewater in BOD plant from Recovery Ovens

Major issues for coke making include availability of suitable coking coals, large capital investment and air pollution control strategies.

3.2.2 Coke properties

High quality coke is characterized by a definite set of physical and chemical properties that can vary within narrow limits.

3.2.2.1 Physical properties

Measurement of physical properties aid in determining coke behaviour, both inside and outside the blast furnace (Figure 3-6).

- The bulk specific gravity of coke is typically around 0.77. It is highly porous.
- The most important properties of coke are ash and sulphur content, which are linearly dependent on the coal used for production. Coke with less ash and sulphur content is highly priced in the market.
- Other important characteristics are the M10, M25, and M40 test crush indexes, which convey the strength of coke during transportation into the blast furnaces (BF); depending on BF size, finely crushed coke pieces must not be allowed into the BF because they would impede gas dynamics.
- The water content in coke is practically zero at the end of the coking process, but coke is often water quenched to reduce its temperature so that it can be transported inside the BF. The porous structure of coke absorbs some water, usually 3-6 % of its mass. In modern coke plants, cooling is practiced by air quenching.
- Coke stability is a property, which measures the ability of coke to withstand breakage at room temperature and reflects coke behaviour outside the blast furnace and in the upper part of the blast furnace.
- A related characteristic is the Coke Strength after Reaction (CSR) index; it represents coke's ability to withstand the conditions inside the blast furnace before turning into fine particles. A large mean size with narrow size variations helps maintain a stable void fraction in the blast furnace permitting the upward flow of gases and downward of molten iron and slag thus improving blast furnace productivity.

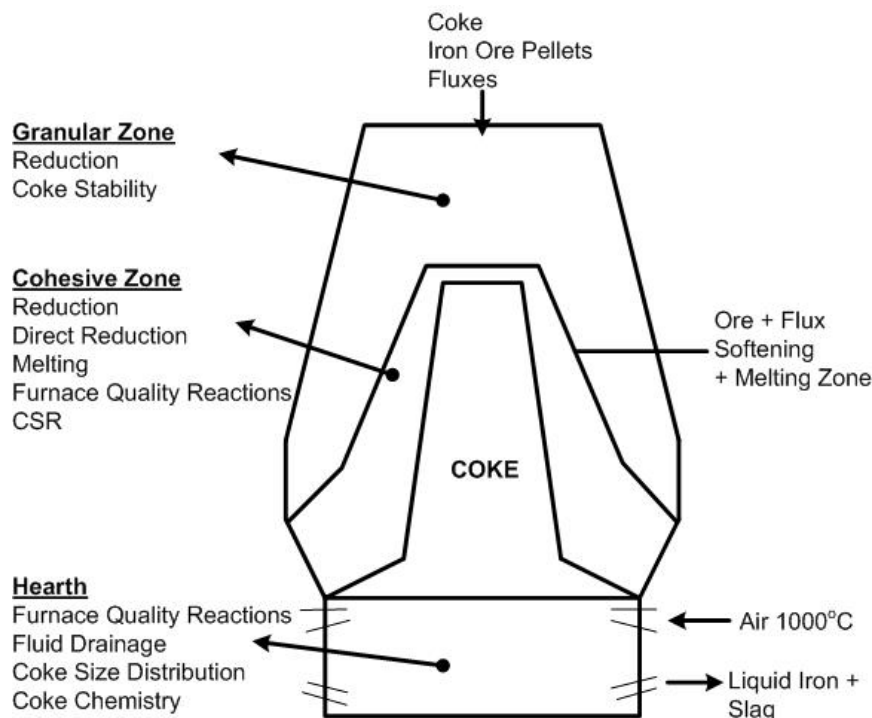

Figure 3-6: Blast Furnace Operating Zones and Coke Behavior

Table 3-1: Coke Quality Specifications

Physical : (measured at the blast furnace)	Mean	Range
Average Coke Size (mm)	52	45-60
Plus 4" (% by weight)	1	4 max
Minus 1" (% by weight)	8	11 max
Stability	60	58 min
CSR	65	61 min
Physical : (% by weight)		
Ash	8.0	9.0 max
Moisture	2.5	5.0 max
Sulphur	0.65	0.82 max
Volatile Matter	0.5	1.5 max
Alkali (K ₂ O + Na ₂ O)	0.25	0.40 max
Phosphorus	0.02	0.33 max

Usually, coke contains 80-86% carbon, 2-6 % moisture, from 0.4 -0.7 % sulphur (the best grade), upto 15% ash, and 0.7 to 2.5 % volatile matter. The heat value of coke is anywhere between 6500 and 7000 kcal/kg. Coke is usually crushed to a lump size of not less than 25 mm.

3.2.2.2 Chemical composition

The most important chemical properties are moisture, fixed carbon, ash, sulphur, phosphorus, and alkalis. Fixed carbon is the fuel portion of the coke; the higher the fixed carbon, the higher the thermal value of coke. The other components such as moisture, ash, sulphur, phosphorus, and alkalis are undesirable as they have adverse effects on energy requirements, blast furnace operation, hot metal quality, and/or refractory lining.

3.2.2.3 Factors affecting coke quality

A good quality coke is generally made from carbonization of good quality coking coal. Coking coals are defined as those coals that on carbonization pass through softening, swelling, and resolidification to coke. One important consideration in selecting a coal blend is that it should not exert a high coke oven wall pressure and should contract sufficiently to allow the coke to be pushed from the oven. The properties of coke and coke oven pushing performance are influenced by following coal quality and battery operating variables: rank of coal, petrographic, chemical and rheologic characteristics of coal, particle size, moisture content, bulk density, weathering of coal, coking temperature and coking rate, soaking time, quenching practice and coke handling. Coke quality variability is low, if all these factors are controlled. Coke producers use widely differing coals and employ many procedures to enhance the quality of the coke and to enhance the coke oven productivity and battery life.

3.2.3 Technological interventions for improving quality of coke

The current technological scenario suggests that the new technologies for iron production have still not reached sufficient levels to eliminate blast furnace route of iron making. Thus, coke ovens will continue to exist and the challenge of producing better quality coke for higher sophisticated blast furnaces will exist. Over the last two or three decades blast furnaces have increased considerably both in size and sophistication and these changes have necessitated a high standard performance of the coke used. Obviously coke oven operators are under constant threat of not reaching up to the desired standard.

One of the major problems encountered by Indian coke oven has been the continuous deterioration in quality of coal resulting in coke with high ash content and poor strength. This has contributed to phenomenal increase in the demand of coke in blast furnaces in India as compared to developed countries. Several technologies were developed in order to combat this problem. Technologies which can be considered for improving coke quality are:

- Pre-carbonization technologies
- Carbonization technologies
- Post-carbonization technologies

Each of the above technologies is discussed in subsequent sections.

3.2.3.1 Pre-carbonization technologies

Among the pre-carbonization technologies, the following are gaining more importance:

- Selective crushing of coal
- Stamp charging of coal
- Partial briquetting of coal charge
- Preheating of coal charge
- Solvent refining of coal

a) Selective crushing of coal

The selective crushing technology improves the quality of coal blend by ensuring fine crushing and even distribution of harder and mineral matter rich particles leading to homogeneity, and better control in variation of size consistency of coal charge thereby producing good quality coke (M10 index improves by 1.5 to 2 points w.r.t a base value of 12 to 14). The processes based on mechanical type screen (Umbra), electrical heated screen and centrifugal screen could not gain success on commercial scale due to operational and maintenance (O&M) problems and lower throughput capacities. The process based on pneumatic classifier as developed in erstwhile Soviet Union has become successful on commercial scale.

b) Stamp charging of coal

Stamp charging process has been in existence for the last 70 years. Even in India this technology was employed at Fertilizer Corporation of India (FCI), Sindri but this did not work successfully due to problems associated with breakage of coal cake. With further development of technology, especially the development of stamping machine, several plants have come up in late seventies and eighties with the latest one at TISCO, Jamshedpur based on Saarberg Interplan (Germany) technology.

The major benefits which can be derived from stamp charging technique are improvement in bulk density of coal charge (by about 35%), increase in oven throughput (7-15%), coking coal conservation due to use of higher proportion of high volatile and poor coking coal in the blend, improvement of coke quality (M-10 improves by 3-5 points with respect to a base value of 12 to 14), lower coke reactivity, increase in blast furnace coke yield (3 to 4%), *etc.* At TISCO, operation of stamp charged battery is stabilized. The improvement on the strength is reported to be quite substantial (M-10 value of 5.5 was achieved as against 7.2 for top charged battery). Apart from this, indigenous prime coking coal was totally eliminated from blend with the use of 80% medium coking coal and 20% imported coal.

c) Partial briquetting of coal charge (PBCC)

The PBCC process enables partial utilization of lower grade/non-coking coal in the form of briquettes along with coal charge. This process is quite suitable for a country like India, which does not have sufficient reserves of good coking coal. Presently there are two main commercialized briquette blend coking processes, *e.g.*

- Briquettes blend coking process developed by M/s Nippon Steel Co. (Nihon Otto K.K.) Japan.
- Sumi-coal system developed by M/s Sumitomo Metal Industries Ltd. Japan.

The first PBCC Plant was installed in 1971 in Tobata Works, Japan. India's first PBCC plant was commissioned in June 1990 at Bhilai Steel Plant by M/s Otto India. The Plant is reported to be working successfully giving an improvement of about 1.5 points in M-10 value over a base value of 11

d) Pre-heating of coal charge

Pre-heating of coal before charging enables use of blend containing substantial quantity of poor coking coal. In this process the coal charge is preheated to around 200-250 °C before charging. Preheating enables increased coal throughput per oven, improves coke quality and enables use of inferior grade coal. Other benefits are overall heat economy and less thermal stress on oven brickwork. The preheating processes which have been developed on commercial scale are:

- Coal-tek system
- Thermocharge system
- Precarbon process

This technology has not sustained well in the world due to problems associated with handling of preheated coal.

e) Solvent refining of coal

Solvent refining of coal (SRC) is a technology for beneficiation of high ash and poor coking coals to get a practically ash-free low sulphur product in solid and/or liquid form. When compared to other technologies available, SRC serves the dual objective of bringing down blend ash level and improving the coking characteristics of coal blend. It also allows substitution of a portion of prime coking coal by non-coking coal in the coal blend. SRC technology is presently in developmental stage. Extensive research work was carried out for SRC technology in USA, Germany and Japan and semi-commercial

plants were set up. In India developmental work on SRC has been continuing under SAIL-CSIR MISSION Programme. Presently CFRI, a unit of CSIR is planning to install a continuous process development unit (PDU) for generating data and optimizing process parameters. Japan International Cooperation Agency (JICA) has been entrusted by Government of India to jointly carry out tests on Indian coal and prepare a pre-feasibility report for setting up a 500 tonnes per day (TPD) SRC demonstration plant in India where MECON, RDCIS & CFRI are assisting JICA for conducting the study.

3.2.3.2 Carbonization technologies

Developments of carbonization technologies have taken place with a view to achieve maximum techno-economic benefits. With high capital intensive nature of coke ovens, the need was felt to get higher specific throughput per oven, which resulted in the emergence of high capacity high throughput ovens. Higher capacity ovens could be achieved by increasing the height and/or width of the ovens. In order to improve the coke output per oven, not only the oven sizes were increased, but faster carbonization was adopted by increasing flue temperature, narrowing oven width and by adoption of thinner walls. But with very high capacity and very tall ovens, the trend is reversed in today's scenario whereby the oven widths are becoming more. Chamber volumes of coke ovens started in earlier times with some 20 m³ in connection with oven heights of 4 m, reached approximately 50 m³ for 7 m batteries leading to 76 m³ with an oven height of 7.6 m. In addition to the increased oven heights also the chamber width has been changed from former 400 mm to 450 mm to approximately 600 mm. This development is shown in Figure 3-7 and Table 3-3.

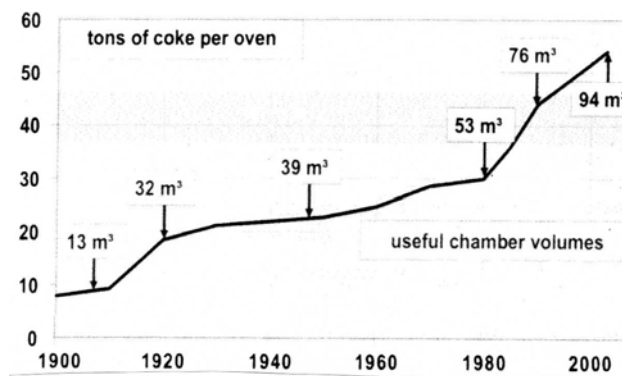

Figure 3-7: Development of Oven Chamber Volumes

At present, ovens with heights up to 7.85 m, width up to 610 mm and volume exceeding 70 m³ are available based on commercial scale plants installed/under installation. The world trend is clearly towards installation of such high volume ovens, one battery of which replaces 2 to 3 small batteries. Further improvements have been reached at least with the coking plant Schwelgern in Germany with an oven height of 8.4 m and a chamber volume of 93 m³.

Table 3-2 summarizes the main technical features of different units for an annual coke production of 2 Mt of coke.

Table 3-2: Comparison of Ovens with different Heights and Useful Volumes

Oven Height	7.6 m	6.0 m	4.3 m
Number of batteries	2	4	5
Number of ovens	140	220	325
Useful volume per oven	76 m ³	34 m ³	20 m ³
Number of pushes/ charges per day	135	300	520
Total length of sealing (doors, stand-pipes, charging holes)	4.8 km	6.0 km	6.5 km
Required space for batteries	40,000 m ²	50,000 m ²	55,000 m ²
Sets of oven machines	2	3	5
Operation teams	1	2	3

3.2.3.3 Post-carbonization technologies

One of the most significant areas of post-carbonization technologies is dry cooling of coke in an inert atmosphere. In conventional practice, hot coke is pushed from the oven and quenched by means of water spray. In wet quenching of coke about 0.36 to 0.42 Gcal heat is lost per tonne of coke. Coke quality also deteriorates and causes water pollution due to water quenching. Post-carbonization technologies are basically aimed at affecting the heat economy of coking process, increasing the coke strength and pollution control. With a view to improve economic recovery of sensible heat in hot coke, coke dry cooling technology was developed and adopted on a commercial scale.

Coke dry quenching (CDQ) is an alternative to the traditional wet quenching of the coke. It reduces dust emissions, improves the working climate, and recovers the sensible heat of the coke. Hot coke from the coke oven is cooled in specially designed refractory lined steel cooling chambers by counter-currently circulating an inert gas medium in a closed circuit consisting of a cooling chamber, dust collecting bunker, waste heat boiler, dust cyclones, mill fan, blowing device (to introduce the cold air from the bottom) and circulating ducts. Dry coke quenching is typically implemented as an environmental control technology. Various systems are used in India, Brazil, Finland, Germany, Japan and Taiwan, but all essentially recover the heat in a vessel where the coke is quenched with an inert gas (nitrogen). The heat is used to produce steam, which may be used on-site or to generate electricity.

During the first year of operation of coke dry cooling plant at Vishakapatnam, observed major highlights are:

- Improvement in coke quality in comparison to 7m tall battery at BSP.
 - M-40 - 6 points
 - M-10 - 2 points
- Steam generation 0.53 t / t of coke against a norm of 0.45 t / t of coke
- Thermal efficiency Over 80%
- Chamber availability Over 80%

M/s Kress Corporation, USA has developed a coke dry cooling system recently where instead of pushing into a coke car the hot coke is transferred and supported in a container and preserves it in loaf form during cooling, thereby retaining its natural fissures, porosity and cake cleavage produced during carbonization process and cooling carried out by circulation of water in the external annular chamber. This first-of-its-kind plant was reportedly commissioned in the last quarter of 1990. Another development under post-carbonization technologies is combi-coke process. Combi-coke process couples the coke dry cooling and preheating of coal to combine the benefits of both the technologies. Among the other post-carbonization technologies, coke stabilization is one of the simplest methods adopted for improving the strength of coke. Coke stabilization is an operation through which the larger and more friable lumps of coke are reduced to more stable coke lumps of required size range. This is done by mechanical conditioning operation, which involves either dropping the coke from predetermined height over an impact plate or subjecting the coke to rotations in large barrel drums or micum drums. The major advantages of coke stabilization include better coke strength indices and lesser generation of fines during handling.

Modified wet quenching

CSQ (Coke Stabilization Quenching) is an advanced wet quenching system with low environmental impact. It was developed as an environmental friendly alternative to CDQ (Coke Dry Quenching). The emissions of dust are as low as for a CDQ and the gaseous emissions are even less. Besides, investment and O&M costs are substantially lower. The process itself is a combination of bottom and top quenching methods, providing extremely short cooling time. CSQ system is shown in Figure 3-8.

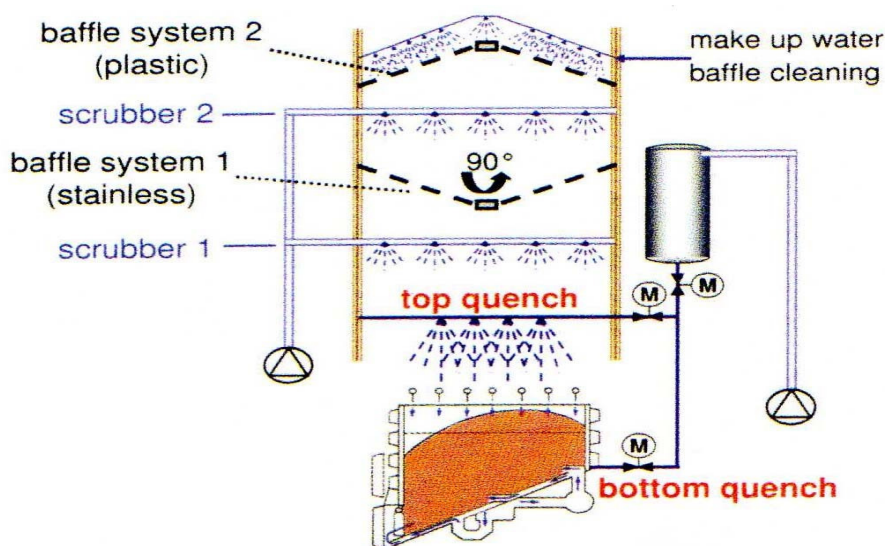

Figure 3-8: CSQ-Quench System

The coke is popped-up approximately 30 m during quenching. An additional hood inside the quench tower prevents the down falling coke from being deposited outside the quench car. The coke is fairly stabilized by the described handling and needs no further treatment except screening as usual.

Formed coke process

Good coking coal can be obtained from coal blends containing substantial proportions (70-100%) of poor coking coal (medium & weakly coking coal) and non-coking coal using the technique of formed coke. The first commercial plant was set up in USA by FMC Corporation in 1961. Since then several formed coke plants came into existence with variation in the process scheme. Some of the major formed coke processes are:

- FMC formed coke process
- Consol BNR Process
- Clean coke process
- BF-L process
- Ancit process
- HBNPC process
- DKS formed coke process
- CFRI process

Though there are differences in various processes, the basic process steps can be summarised as:

- Breaking/crushing of coal to a required size
- Carbonize either lumps or fines to drive out the volatile matter (some of the processes do not require carbonization before briquetting) resulting in char (carbonized coal fines/crushed carbonized lumps)
- Addition of binder (processed tar) to char or coal fines (some of the processes use coking coals partly as binder instead of tar/pitch)
- Shapping/briquetting the above mixture in processes to give it a particular shape and size, strength and permeability
- Calcine or heat harden the shape/briquettes, cure the same to produce formed coke.

3.2.4 Industrial processes in the context of environmental pollution

3.2.4.1 Process description for by-product recovery type

Coking process is the most important aspect to make comprehensive usage of coal. It shows that coal was carbonized and becomes coke under high temperature with generation of coke oven gas and various chemical products. A coking plant mainly comprises of coal preparation, coking, coke quenching and screening, and gas purification, *etc.* Typical flow diagram of a coke-oven plant showing sources of emissions/wastes is depicted in Figure 3-9.

Coke Oven Plants

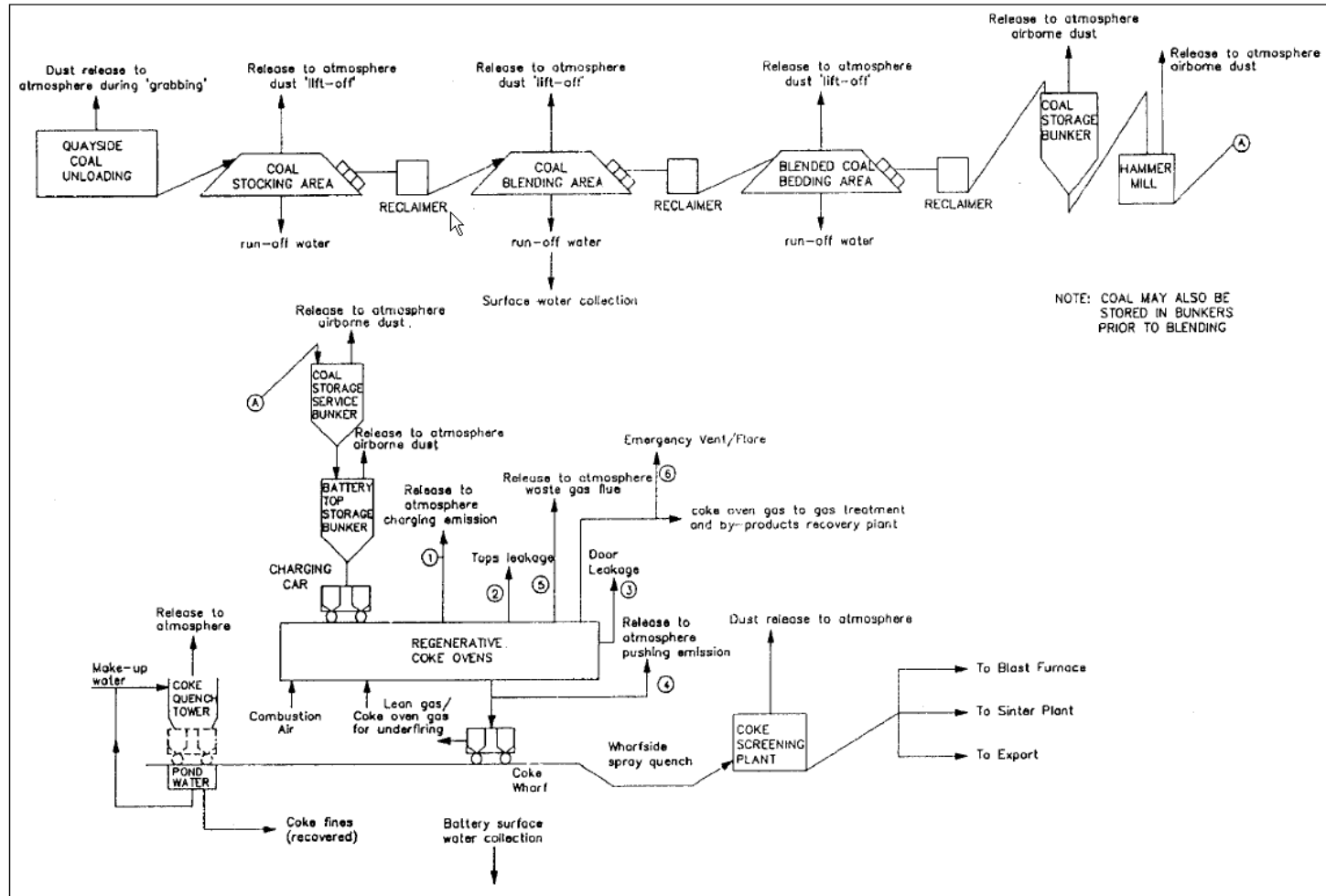

Figure 3-9: Typical Flow Diagram of a Top Charged Coke Oven Plant Showing Emission Sources

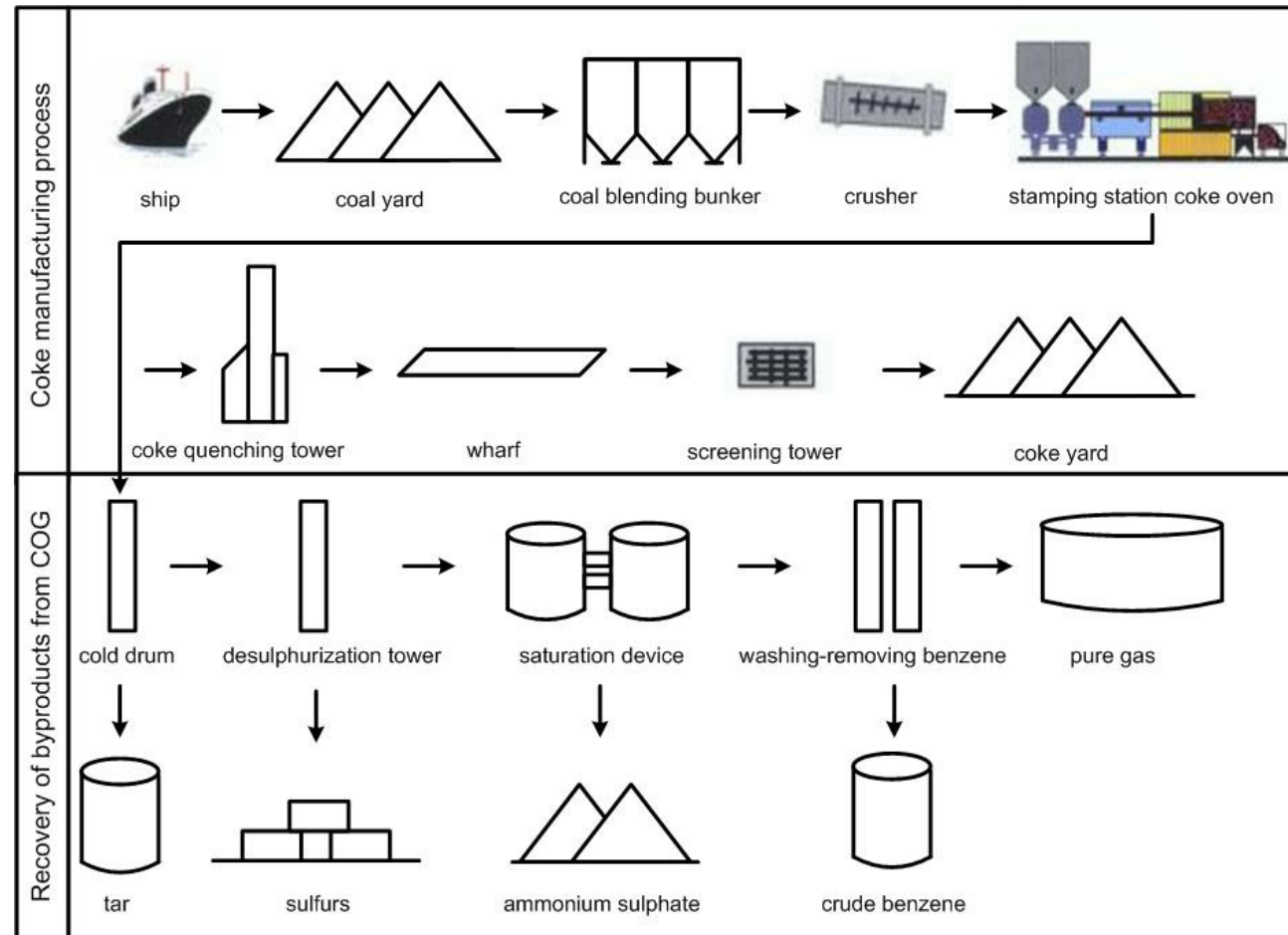

Figure 3-10: General Process Flow Chart - Stamp Charge Coke Oven Battery with other facilities

Coal Preparation

This stage includes coal receiving, blending, crushing and mixing. Coal is stored in coal yard separately as per different categories and delivered to different coal blending hoppers by belt conveyor. Several categories of coal will be proportioned in blending hopper, then, crushed and mixed in crushing house and delivered to coal tower. Coking is the process of blended coal being carbonized under high temperature in carbonization chambers to produce coke and crude gas. Coal can be charged in the ovens in two broad ways:

- From top through coal charge cars traveling on the top of the batteries. Lids are provided on battery top for receiving coal charge. This is the most commonly followed practice in India.
- From side after preparing the coal charge in the form of a cake and sliding the cake through pusher side doors. This is a new practice followed by some of the Indian plants. All other processes remain the same as top charge battery. The process is composed of coal stamping, charging, coking, coke discharging. After stamping, formed cake will be charged to the carbonization chamber by charging car for softening, melting, solidification, shrinkage, and then forms coke. The final coke will be pushed out of the carbonization chambers by pushing and charging car and transfer to the next stage treatment. Abundant crude gas produced during carbonization process will be cooled down to around 83°C at high line by spraying ammonia water and then via header delivered to gas purification shop for treatment. This section includes the following main equipment:
 - Coke oven
 - Stamping station
 - Charging and pushing car
 - Coke guarding car
 - Quenching car
 - Quenching & Screening

Temperature for carbonization chamber is around 1000 °C. Wet quenching method is the most popular method to be used at present. Dry quenching being the latest technique is slowly becoming popular in India. Hot coke will be delivered to quenching tower, cooling water will quench and cool own coke to environment temperature, then it will be discharged onto wharf and remained for 30 minutes, then delivered to screening tower. After screening, coke grade will meet client requirement.

Cold condensation & air blowing

Temperature of crude gas in the header is around 83 °C. It is mingled with abundant tar and gas. To facilitate the utility and delivery, crude gas needs to be cooled down to 25 °C. Tar and ammonia water are condensed and drawn out. In order to induce crude gas from coke oven smoothly and maintain gas pressure, which is required by the sequential process of coal gas purification, cooled gas needs to be pressurised by compressor. Pressurised coal gas will be brought to desulphurization section for desulphurization treatment.

Main equipment in this section mainly composes of cooler, electrical tar trapper, air blower. The main product is tar.

Desulphurization

The content of sulphur in gas shall be de-sulphured to below 200mg/m³ in order to meet the requirements of gas users and recovering consequent chemical products. Presently, we adopt wet-type oxidation desulphurization process, which was widely accepted with the salient features like – eco-friendliness, compact, easy-to-operate, highly efficient desulphurization, *etc.* In addition, sulphur will be produced in the section of desulphurization, which can be used to produce sulphuric acid.

The major equipment of desulphurization section is as follows:

- Desulphurization tower, regenerating tower, ammonia vaporising tower
- Main product: sulphur

Sulphur-Ammonium Section

The content of ammonia in gas shall be purified below 100 milligrams per cubic metre (mg/m³) to meet the requirements of gas users and gas transportation. Presently, there are two widely adopted and applied technologies: sulphur-ammonium process and ammonia decomposition process. However, the former is more widely used, due to the reason that it can produce sulphur-ammonium products with low cost, and it is more economic and practicable. The principle of sulphur-ammonium process is to use sulphuric acid to absorb ammonia in the gas, and then produce sulphur-ammonium products.

- The major equipment of sulphur-ammonium section : saturator
- Main product: ammonium sulfate

Benzol Scrubbing

Benzene is an important chemical material, which has high economic value. Benzene scrubbing means to use washing oil (tar or petroleum) to absorb benzene in gas. After passing through scrubbing tower, benzene can be separated and made into semi-finished benzene products, which can be further refined or for sale, washing oil can be recycled after benzene scrubbing.

The major equipment of washing-removing benzene section shows as follows:

- Benzene scrubbing tower, benzene removing tower
- Main products: semi-finished benzene products, pure gas

Crude gas from coke oven can be purged into high caloric coke oven gas after purification process and chemical product recovering. It can be used for both industrial and civil usage, and can also be sent to chemical plant as materials of chemical synthesis.

3.2.4.2 Recovery of by-products from COG

Raw COG has a relatively high calorific content due to the presence of hydrogen, methane, carbon monoxide and hydrocarbons. Furthermore, the raw coke oven gas contains valuable products such as tar, light oil (mainly consisting of BTX (benzene, toluene and xylenes), sulphur and ammonia. Table 3-3 shows the typical composition of raw coke oven gas. The coke oven gas must be treated before used as a fuel.

Table 3-3: Composition of Raw Coke Oven Gas

Raw gas yield [m ³ /h/t coal]	Raw gas density [kg/Nm ³]	H ₂ [vol.%]	CH ₄ [vol.%]	C _x H _y [vol.%]	CO [vol.%]	H ₂ S [vol.%]	BTX [g/Nm ³]	PAH [mg/Nm ³]	NH ₃ [g/Nm ³]	CO ₂ [vol.%]
12-25	0.53-0.62	39-65	32-42	3.0-8.5	4.0-6.5	3-4	23-30	n/a	6-8	2-3

Coke oven gas composition depends on coking time and coal composition. The data given refer to water-free and ash-free coal. The H₂S content of the example given is relatively high. Other plants are typically in the range 3.5 - 4.5 g H₂S/Nm³. Tar and naphthalene in the raw gas may clog the piping and equipment and should be removed first. For each tonne of coke produced, approximately 35 to 45 kg of tar may be recovered. Several products can be recovered from the tar, such as pitch, anthracene oil, wash oil, naphthalene oil, carbolic oil (phenol) and light oil. Sulphur compounds and ammonia cause corrosion of piping and equipment and the sulphur compounds cause emissions of SO₂ when the coke oven gas is used as a fuel. For each tonne of coke produced, approximately 3 kg of ammonia and 2.5 kg of H₂S are generated. In some cases light oil, and especially BTX is recovered from the raw coke oven gas as a valuable by-product. Up to 15 kg of light oil may be recovered per tonne of coke produced. This oil contains benzene, toluene, xylenes, non-aromatics, homologous aromatics, phenol, pyridine bases and other organic compounds such as polycyclic aromatic hydrocarbons (PAH).

Figure 3-11 shows a typical COG treatment plant. The main steps in the process are described in the figure below:

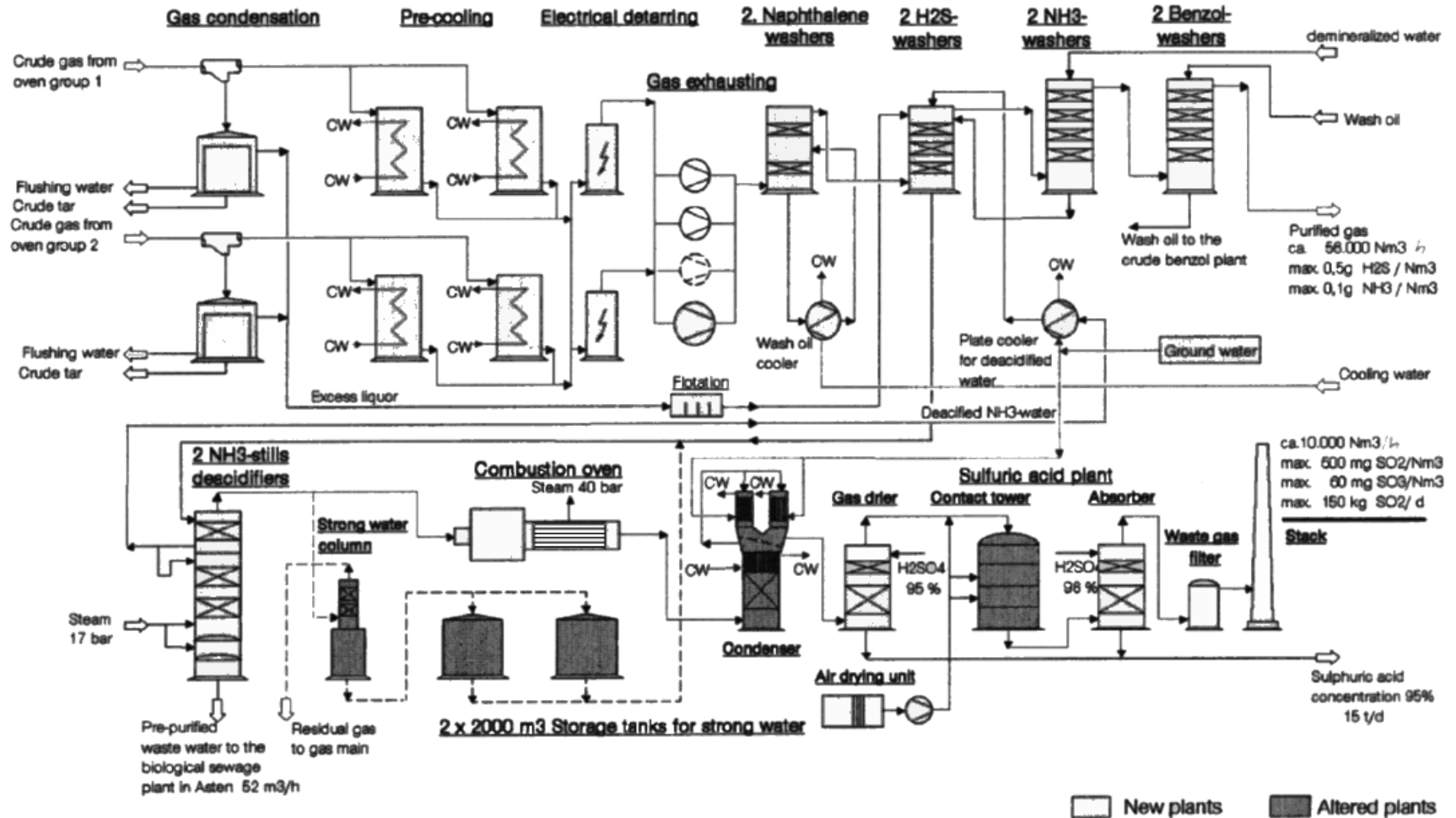

Figure 3-11: Typical scheme of a COG treatment plant with recovery of by-products

Gas cooling

Hot crude oven gas enters the ascension pipes at a temperature of approximately 800°C. In the goose neck it is directly cooled by an ammonia liquor spray to a steam saturation temperature of around 80°C. This requires 2-4 m³ of ammonia liquor for each tonne of coal carbonised. The liquid phase, *i.e.* the condensate, is fed to the tar/water separator, whilst the gas phase is led to the primary coolers. It used to be common for primary coolers to be operated as open systems. Nowadays, indirect cooling with closed cooling systems is more frequent. When sufficient cooling water of the right temperature is used, the gas can be cooled to below 20°C, given a moderate ambient temperature. Under these conditions most of the higher boiling point compounds and the water from the steam fraction of the gas will condense. Droplets and particles are precipitated in the down-stream electrostatic tar precipitators before the gas is drawn into the washing facilities by exhausters (suction fans). Occasionally electrostatic tar precipitators are installed down-stream of the exhausters. The precipitate from the electrostatic tar precipitator is also led to the tar/water separator. The suction fans cause compression of the gas, and even if the fans are such that this is only slight, the attendant temperature increase cannot be tolerated in view of the down-stream processing conditions. This makes it essential to use so called final coolers. Final coolers may be indirect or direct, in which case the cooling water of which is used to absorb the impurities from the COG. Consequently, at the end of the cooling cycle, during return-flow cooling using natural draft or fan coolers, emissions are inevitably generated. Closed systems are therefore usually preferred for final cooling, though open cycles are still operated at some plants.

Tar recovery from the coke oven gas

Most of the water and the high boiling point hydrocarbons are condensed during coke oven gas cooling. The condensate from the pipes and the electrostatic tar precipitator is led to the tar/water separator, where the tar is recovered. The water phase is separated off as so called “coal water” and led through the ammonia stripper/still prior to further treatment. Sometimes scrapers are installed to remove tar from the condensate. These chunks are usually fed back to the coal feed.

Desulphurisation of coke oven gas

Coke oven gas contains hydrogen sulphide (H₂S) and various organosulphur compounds (carbon disulphide (CS₂), carbon oxisulphide (COS), mercaptans *etc.*). All desulphurization techniques currently in use are highly efficient in removing H₂S. They are less efficient at removing organosulphur compounds. Commercial coke oven gas desulphurisation processes can be divided into two categories:

- processes using wet oxidation to produce elemental sulphur (S⁰);
- processes which absorb and strip H₂S for subsequent conversion into sulphuric acid (H₂SO₄) or elemental sulphur (S⁰).

All wet oxidation processes utilise a reduction-oxidation catalyst to facilitate the wet oxidation of hydrogen sulphide to elemental sulphur (S⁰) or sulphate. All these processes are characterized by very efficient removal of hydrogen sulphide (as low as 2 mg/Nm³), but have the disadvantage of producing highly contaminated wastewater and/or air, which make elaborate treatment facilities a necessary part of the process. Absorption/stripping processes are characterised by generally lower H₂S removal (0.5-1 g/Nm³ after cleaning), but, since air is not included in the regenerating system and no toxic catalysts are used, emissions to air

and water of process related chemicals are minimised or eliminated. The processes can be operated to produce sulphuric acid (sulphuric acid plants), or a very high purity elemental sulphur (Claus plants).

A common process combination is $\text{NH}_3/\text{H}_2\text{S}$ circuit scrubbing in the low pressure stage and potassium carbonate scrubbing (vacuum carbonate process) in the high pressure stage, combined with a BTX washer either at low or at enhanced pressure. Potassium scrubbing at both the pressure stages, combined with a BTX washer is also common.

Recovery of ammonia from the coke oven gas

The ammonia formed during coking appears in both the coke oven gas and the condensate (weak liquor) from the gas. Typically 20-30% of the ammonia is found in the weak liquor. Three techniques are applied commercially to remove ammonia from the coke oven gas:

- **The $\text{NH}_3/\text{H}_2\text{S}$ scrubbing circuit:** In this process, the ammonia is scrubbed from the coke oven gas in an ammonia scrubber using water or dilute liquor wash as a scrubbing liquid. The effluent from the ammonia scrubber is used as scrubbing liquor in the H_2S scrubber. The effluent from the H_2S scrubber contains H_2S and NH_3 and is led to the ammonia stripper and the still. This process is also known as the Carl Still, Diamex or Ammoniumsulfide Kreislaufwäscher (ASK) process.
- **Direct recovery as ammonium sulphate ($(\text{NH}_4)_2\text{SO}_4$):** Two processes can be used i.e the Otto-type absorber and Wilputte low differential controlled crystallization process. In both systems, the COG is sprayed with a dilute sulphuric acid solution and ammonium sulphate is yielded;
- **Direct recovery as anhydrous ammonia (NH_3):** The recovery of ammonia from the gas as anhydrous ammonia has been developed by the United States Steel Corporation under the name USS PHOSAM. In this process, ammonia is scrubbed from the coke oven gas by counter-current contact with an ammonia-lean phosphate solution (phosphoric acid). Ammonia removal efficiency is 98-99%.

Recovery of light oil from coke oven gas

The gas leaving the ammonia absorbers contains light oil, clear yellow-brown oil with a specific gravity of 0.88. It is a mixture of the products of COG with boiling points mostly between 0 and 200°C, containing well over a hundred constituents. Most of these are present in such low concentrations that their recovery is seldom practicable. The light oil is usually referred to as BTX. The principle usable constituents are benzene (60-80%), toluene (6-17%), xylene (1-7%) and solvent naphtha (0.5-3%). Three main methods are used for the recovery of light oil:

- Refrigeration and compression to temperatures below -70°C and pressures of 10 bar.
- Absorption by solid absorbents, in which the light oil is removed from the gas by passing the latter through a bed of activated carbon and recovering the light oil from the carbon by heating with indirect or direct steam.
- Absorption by solvents, consisting of washing the COG with a petroleum wash oil, a coal tar fraction or other absorbent, followed by steam distillation of the enriched absorbent to recover the light oil.

Coke oven water flows

A number of water flows are generated during the coking process and coke oven gas cleaning. Some of these flows are related to coking operations themselves and others are related to coke oven gas treatment. Figure 3-12 shows an example of possible water flows in a coke oven plant. However, many other alternative layouts exist. The water vapour present in the collecting main originates from several sources: coal moisture, "chemical water" (which is formed during the coking process), and steam or ammonia liquor used in the goose necks for the suction of the charging gases.

The crude coke oven gas is led through the primary cooler and the electrostatic precipitator, during which the water vapour and the tar are mostly condensed. The condensed water and tar from the collecting main, the coolers and the electrostatic precipitator are led to the tar/water separator. The water from the tar/water separator contains high concentrations of ammonia and is led to the ammonia liquor storage tank.

The ammonia liquor storage tank provides water for the goose neck spray equipment. The ascension pipe lids are sealed. The surplus water in the ammonia liquor storage tank is led to the ammonia stripper/still. It should be noted that usually all water flows, except for water from closed cooling systems and wet oxidative desulphurisation systems, are eventually drained from the ammonia still and led to a wastewater treatment plant. High concentrations of NH_3 are present in the ammonia still. Ammonia concentration in the wastewater is to be reduced before discharging the water to a wastewater treatment plant or to the environment due to the following specific concerns:

- the ammonia can be recovered as a valuable energy source (in a sulphuric acid plant) or as a valuable by-product (as ammonium sulphate or anhydrous ammonia).
- free ammonia is highly toxic for aquatic ecosystems (including biological wastewater treatment plants);
- ammonia has a very high specific oxygen demand (it requires 4.5 times its own weight of oxygen for oxidation to nitrates). Thus, there is a risk for oxygen depletion of the wastewater treatment plant or the recipient water.

Therefore, ammonia strippers are being installed virtually in all coke oven plants. This device strips H_2S and NH_3 from the liquid by steam and alkaline additives. The vapours are subsequently led to the crude gas or to the $\text{NH}_3/\text{H}_2\text{S}$ scrubbing circuit (to improve H_2S scrubbing efficiency) or to a sulphuric acid plant, where NH_3 and H_2S are incinerated together. Sometimes the NH_3 is removed from these vapours in saturators, producing ammonium sulphate.

The most commonly used alkali is caustic soda (NaOH). Formerly, slaked lime (CaOH_2) was often used. Some possible water flows which may include:

- Wastewater from BTX recovery is led to the tar/water separator.
- Phenol (concentration > 3 g/l) may be recovered from the coal water by a solvent extraction process, before the coal water is led to the ammonia liquor storage tank.
- Wastewater from oxidative desulphurisation processes is usually discharged separately after pre-treatment.
- Chemical water from the (optional) sulphuric acid plant is usually led to the still.

- Chemical water from the (optional) Claus-process will usually not be condensed but discharged to the atmosphere via a stack. An alternative is to inject this water into the raw gas before treatment.
- Cooling water. Indirect gas cooling water is recirculated and will not influence the wastewater quantity. In the case of direct gas cooling, the cooling water has to be considered to be washing liquor and it is eventually drained via the still.

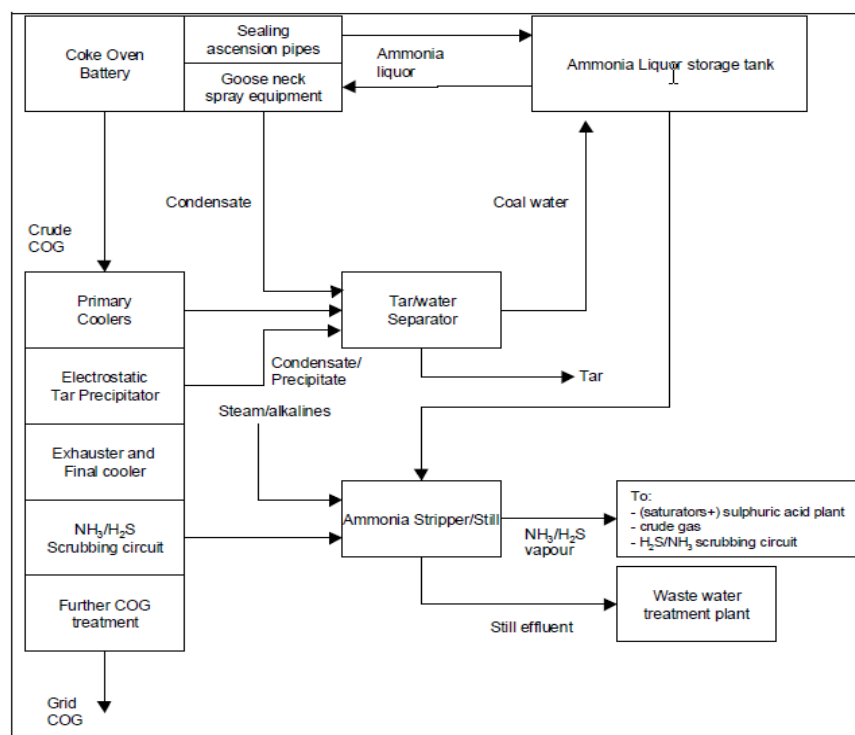

Figure 3-12: Schematic diagram of possible water flows in a coke oven plant

Treatment of phenols, ammonium cyanide in effluent from Recovery Coke Ovens

Wastewater generated during the process of cleaning coke oven gases is toxic in nature due to presence of high phenol, ammonia, thiocyanate and cyanide. This wastewater is commonly treated using biological methods of treatment. In steel industry, these treatment plants are known as Biochemical Oxidation and Dephenolisation Plants (BOD Plants) which have two or three stage biological treatment units. However, functioning of these BOD plants is often affected due to high inlet concentrations, biodegradability and improper operational control. The overall efficiency of biological treatment of coke oven wastewater, even after employing well acclimatized microorganisms, is constrained due to its resistance to biodegradability and inhibition. As all recovery type coke oven plants have a BOD plant for phenolic effluents, it will be advantageous if these can be made more efficient without totally changing the technology.

SAIL, R&D, (RDCIS), Ranchi, has observed that it is essential to increase biodegradability of the effluents by breaking the refractory chemicals prior to biological process in order to achieve high level of overall efficiency. Advanced Oxidation Processes (AOPs) have the potential to enhance biodegradability of toxic constituents and can be a viable pre-treatment and /or post treatment technology for treatment of coke oven wastewater. AOPs are of special interest for wastewater treatment due to their efficiency in minimizing a great variety

of pollutants, including recalcitrant compounds, through the oxidation by generated hydroxyl radicals. AOPs are suited for destroying dissolved organic contaminants such as halogenated hydrocarbons, aromatic compounds (BTX), pentachlorophenols, detergents, pesticides, *etc.* AOPs can also be used to oxidize inorganic contaminants such as cyanides, sulphides, and nitrites.

A partial list of AOP techniques include:

- homogeneous ultraviolet irradiation
- using semiconductor catalysts
- X-ray or gamma ray radiolysis
- ultrasonic irradiation
- electro hydraulic cavitations

Of all these, photochemical and electrochemical techniques were chosen for experiment. The experiment done by RDCIS focused on key parameters like COD, cyanide, ammonia, TSS, turbidity, colour *etc.*

RDCIS recommended the following;

- Electrolytic coagulation coupled with electro-oxidation was found to be having potential application in the steel plant wastewater treatment system. Arrangements can be introduced just before mixing units.
- It was observed that significant amount of floc was generated during electrolysis, which was found to float. This may lead to easier removal of constituents.
- The process needs to be optimized on a plant scale by controlling reaction chamber materials (iron, aluminum, titanium, graphite, *etc.*), amperage, voltage, flow rate, and the pH of water. The technology can handle mixed waste streams (oil, metals, and bacteria).

3.2.5 Specific energy consumption factors

An integrated iron and steel plant in India has poor records of specific energy consumption and it touches about 5 GCal/t crude steel. There are considerable possibilities of reduction in specific energy consumption from coke oven plants. As stated before, coke production consumes about 50% energy of an integrated iron and steel plant. About 45% of this is the sensible heat of red hot coke coming out of the coke oven. Conventionally, red hot coke comes immediately after coking, which have the temperature of about 1000-1200 °C, are cooled by water spray, and the sensible heat is dissipated into the atmosphere. Coke dry quenching is to recover this waste heat by performing heat exchange with inert gas in a sealed vessel, heating the gas up to 800 °C and generating steam by a waste heat boiler. Reduction of energy consumption is about 291,000 kCal/t coke. (1217 MJ/t coke) Another possible specific energy consumption reduction is coal drying. Energy saving of 40,000-80,000 kCal/t coke can be achieved to reduce moisture from 7-11% to 6%. This is more relevant if coking coal is imported as Indian coal supplied has generally less moisture. Automatic combustion control of coke ovens is yet another source to reduce specific energy consumption. Amount of carbonization energy reduced is about 40,000 kCal/t coke at coke production of 1,500 kt/year.

3.2.6 Qualitative and quantitative analysis of rejects

The approximate amount of important harmful substances exhausted into the atmosphere from the by product type coke oven plant is given in the Table 3-5 below:

Table 3-4: Specific Emission of harmful substances in atmosphere from by-product recovery type coke oven plants

Name of the shop	Volume of exhaust products, m ³ /t	Amount of pollutants released, g/t of coke										
		Dust	H ₂ S	NH ₃	HCN	C ₆ H ₅ O H	HC	SO ₂	CO	NO ₂	3,4 benzp yrene	
Coal Preparation	3000	700										
Battery, fired with COG	1400											0.06
Battery, fired with BF Gas	1750											
Battery, top Coal Charging	185	400	21.8	47	0.6	1.1	190	32	46	88		
Battery, Coke Pushing	190	750	7.6	51		0.5	36	22		3.4		
Coke transfer to Quenching station	100	110	0.2				70	16	31	2.9		
Wet Quenching Tower	600-650		20	42	9.1	85						
Coke Wharf	735		0.3	0.5	0.2	0.2						
CDQ		390										
Coke Sorting plant		700										

3.2.7 Exposure Pathway

Exposure pathway is the path due to which exposure of the receptor takes place. The “exposure” has been defined as contact with a chemical or physical agent. It is the process by which an organism acquires a dose. The estimation of exposure of a target organism requires an exposure scenario that answers to four questions:

- given the output of fate models, which media (ecosystem components) are significantly contaminated
- to which contaminated media are the target organisms exposed
- how are they exposed (pathways and rates of exposure)
- given an initial exposure, will the organism modify its behaviour to modify exposure pathways or rates (attraction or avoidance)

For environmental risk management there are three major risk factors and exposure pathway is one of three factors. To determine whether the risk management actions are warranted, the following assessment approach should be applied to establish whether the three risk factors of ‘Contaminants’, ‘Receptors’, and ‘Exposure Pathways’ co-exist, or are likely to co-exist, at the project site after the operational phase of the proposed development.

- Contaminant(s): Presence of pollutants and/or any hazardous materials, waste, or oil in any environmental media at potentially hazardous concentrations
- Receptor(s): Actual or likely contact of humans, wildlife, plants, and other living organisms with the contaminants of concern
- Exposure pathway(s): A combination of the route of migration of the contaminant from its point of release (e.g., leaching into potable groundwater) and exposure routes

Table 3-5 identifies some of the major exposure pathways.

Table 3-5: Exposure Pathways

Media	Pathways	Comment
Air-Gases and Aerosols	Respiration	Assuming accurate fate model estimates, exposure is relatively predictable based on assumption of homogenous distribution in air
Water – Soluble Chemicals	Respiration	Assuming accurate fate model estimates, exposure is relatively predictable based on assumption of homogenous distribution in water
Sediment (Solids and pore water)	Benthic animals absorb chemicals, respire pore water or food or food from the water column. Plants rooted in the sediment may take up material from sediments, surface water and air	Processes are very complicated and usually simplifying assumptions are required
Soil (solids, pore water and pore air)	Organisms in soils may absorb material from soil, pore water, pore air, ingest soil, soil – associated food.	Processes are very complicated and usually simplifying assumptions are required.
Ingested Food and Water	Consumption by fish and wildlife	Assume the test animal consumption rates in laboratory for a given availability of food or water are the same as those occurring naturally in the environment.
Multimedia	More than one of the above pathways	It is often possible to assume one pathway is dominant. In some cases, it will be necessary to estimate the combined dosage.

Coke oven plant emissions or rejects (gaseous, solid & hazardous as well as liquid effluents) can cause damage to human health, aquatic and terrestrial ecology as well as material due to various exposure routes (pathways). For example adverse effects of coke oven plants on human health can derive from the direct impact of noxious gases on the organism and/or their indirect impact via the food chain and changes in the environment. Especially in connection with high levels of fine particulates, noxious gases like SO₂ and NO_x can lead to respiratory diseases. SO₂ and NO_x can have health-impairing effects even at concentrations below those of standard of 120 µg/m³. The duration of exposure is decisive. Injurious heavy metals (*e.g.*, lead, mercury and cadmium) can enter the food chain and, hence, the human organism by way of drinking water and vegetable and animal products. Climatic changes such as warming and acidification of surface waters, Forest depletion can occur due to acid rain and/or the greenhouse effect of CO₂ and other trace gases can have long-term detrimental effects on human health. Similarly important are the effects of climatic changes on agriculture and forestry (and thus on people's standard of living), *e.g.*, large-scale shifts of cultivation to other regions and/or deterioration of crop yields due to climate change impacts. Hence, the construction and operation of coke oven plants can have both socio-economic and socio-cultural consequences; appropriate preparatory studies, gender-specific and otherwise, are therefore required, and the state of medical services within the project area must be clarified in advance. In addition, noise pollution generated from turbines is an important source of occupational exposure, has direct effect on humans and animals. The main sources of noise are the mouth of the smokestack, belt conveyors, fans, motors/engines, transformers, flues, piping and turbines.

3.3 Technological Aspects

3.3.1 Cleaner technologies

a) Modified wet quenching

CSQ is an advanced wet quenching system with low environmental impact. It was developed as an environmental friendly alternative to CDQ. The emissions of dust are as low as for a CDQ, the gaseous emissions are even less. Investment, O&M costs are substantially lower. The process itself is a combination of bottom and top quenching, providing extreme short cooling time.

Energy/Environment/Cost/Other Benefits:

- No energy recovery is possible
- Emission of less than 10g of particles per ton of coke has been reached
- Cost is low

b) Coke dry quenching

Coke dry quenching is an alternative to the traditional wet quenching of the coke. It reduces dust emissions, improves the working climate, and recovers the sensible heat of the coke. Hot coke from the coke oven is cooled in specially designed refractory lined steel cooling chambers by counter-currently circulating an inert gas media in a closed circuit consisting of a cooling chamber, a dust collecting bunker, a waste heat boiler, dust cyclones, a mill fan, a blowing device (to introduce the cold air from the bottom) and circulating ducts. Dry coke quenching is typically implemented as an environmental control technology. Various

systems are used in Brazil, Finland, Germany, Japan and Taiwan, but all essentially recover the heat in a vessel where the coke is quenched with an inert gas (nitrogen). The heat is used to produce steam, which may be used on-site or to generate electricity. It is now adopted in India in a big way for Greenfield steel plants.

Energy/Environment/Cost/Other Benefits:

- Energy recovered is approximately 400-500 kg steam/t, equivalent to 800-1200 MJ/t coke. Others estimate energy conservation through steam generation (0.48t/t coke). Electricity generation.
- New plant costs are estimated to be \$50/t coke, based on the construction costs of a recently built plant in Germany; retrofit capital costs depend strongly on the lay-out of the coke plant and can be very high, up to \$70 to \$90/GJ saved
- Decreased dust, CO₂ and SO_x emissions
- Increased water efficiency
- Better quality coke produced, improved strength of coke by 4%

c) Coal moisture control

Coal Moisture Control (CMC) operation has been introduced in coke manufacturing process in Japan. This process is aiming at decreasing the quantity of heat consumption for carbonization, improving the coke quality and raising the productivity by decreasing moisture content in coal charge. Although CMC operation offers such advantages, the negative aspect is carbon deposits on the coke oven chamber, which is under study.

Coal moisture control uses the waste heat from the coke oven gas to dry the coal used for coke making. The moisture content of coal varies, but it is generally around 8-9% for good coking coal. Drying further reduces the coal moisture content to a constant 3-5%, which in turn reduces fuel consumption in the coke oven. The coal can be dried using the heat content of the coke oven gas or other waste heat sources.

Energy/Environment/Cost/Other Benefits:

- Fuel savings of approximately 0.3 GJ/t
- Coal moisture control costs for a plant in Japan were \$21.9/t of steel
- Coke quality improvement (about 1.7%)
- Coke production increase (about 10%)
- Shorter cooking times
- Decrease in water pollution (ammonia reduction)

d) High pressure ammonia liquor aspiration system (HPALA)

The HPALA system is effective for controlling charging emissions in coke oven batteries. This is very popular in India. In this system, the ammoniacal liquor, which is a byproduct in the coke oven, is pressurized to about 35-40 bar and injected through special nozzles provided in the gooseneck at the time of charging. This creates sufficient suction inside the oven, thereby retaining pollutants from being released into the atmosphere. The system consists of high-pressure multistage booster pumps, sturdy pipe-work, specially designed spray nozzles, suitable valves and control instruments.

Energy/Environment/Cost/Other Benefits:

- Emissions control
- High reliability and simplicity of operation
- Low operational and maintenance costs
- Appreciable saving in quantity of process steam required and increased raw gas yield/byproducts generation, due to elimination of gases vented into the atmosphere

e) Modern leak-proof door

Coke oven leaking doors can be a major source of pollution. With the advent of recovery type ovens, the design of oven doors has gone through a process of evolution, beginning from luted doors to the present generation self-regulating zero-leak doors. Such doors are now available in India and are being installed by many steel plants. The important features of the leak-proof door include: (1) a thin stainless steel diaphragm with a knife edge as a sealing frame built in between the door body and the brick retainer, (2) spring loaded regulation on the knife edge for self-sealing, (3) provision for air cooling of the door body, and (4) large size gas canals for easier circulation of gas inside oven.

Energy/Environment/Cost/Other Benefits:

- Minimisation of door leakage
- Regulation free operation
- Longer life due to less warping of the air cooled door body
- Reduced maintenance frequency
- Conventional doors can be replaced by leak-proof doors without altering battery/door frame Design Ikio design Simplex doors have achieved a PLD of 1% against the CPCB norm of 5% while retrofitted at Battery 3 of BSP in India.

f) Land-based pushing emission control system

The smoke and fumes produced during the pushing of red hot coke contains a huge amount of coke dust (estimated at 11% of the total pollution in the coke oven). Land-based pushing emission control systems mitigate this pollution. New steel plants in India are installing this system as technology is now available. It consists of three parts: (1) a large gas suction hood fixed on the coke guide car and moving with the coke guide, sending fumes to the coke side dust collecting duct; (2) the dust collection duct; and (3) the final equipment for smoke purification on the ground (ground piping, accumulator cooler, pulse bag dust collector, silencer, ventilation unit, stack, etc). The large amount of paroxysmal high-temperature smoke produced during coke discharging is collected under the hot float fan into the large gas suction hood installed in the coke guide car, and enters the dust collection duct through the other equipment.

The air is dissipated into the atmosphere after purification by the pulse dust collector and after being cooled by the accumulator cooler. The total de-dusting system is controlled by PLC.

Energy/Environment/Cost/Other Benefits:

- Elimination of pushing emission up to a large extent

g) Advanced technologies for desulphurization of coke oven gas

Because of hydrogen sulphide (H_2S) content up to 9 g/Nm^3 in unpurified coke oven gas, it is unsuited for use in many industrial applications. $3.5 - 4.5 \text{ g/Nm}^3$ is observed in Indian coke oven plants. Also, as per the MoEF guidelines, the sulphur content in coke oven gas used for heating should be limited to 800 mg/Nm^3 . When the gas has been desulphurized, its use for a variety of applications becomes potentially viable. Among many processes, Wet Oxidation Process (Stratford process) and Absorption/Stripping Process (ASK or Diamex process) described here can reduce H_2S content satisfactorily. In Stetford process, H_2S is scrubbed from the coke oven gas by a sodium carbonate solution (Na_2CO_3) and elemental sulphur (S^0) is yielded using vandate (VO_3) as an intermediate. Regeneration of the scrubbing liquid takes place by aeration (O_2), using anthraquinone disulphonic acid (ADA) as an intermediate. In ASK or Diamex process, H_2S is scrubbed from the coke oven gas by a NH_3 solution. The NH_3 solution is derived from the NH_3 scrubber. The H_2S and NH_3 are stripped from the washing liquor by steam stripping and the vapours are led to a Clause plant or a Sulphuric Acid plant.

Energy/Environment/Cost/Other Benefits:

- H_2S reduction up to 2 mg/Nm^3 is possible in wet oxidation process.
- In absorption process, H_2S reduction up to 500 mg/Nm^3 is possible.
- Annual debt service on capital cost is around 11% and annual maintenance on capital cost is around 4% in both the cases.

3.3.2 Pollution control technologies

a) Recovery type coke oven battery

The recovery type coke oven plant is the source of pollution of the air and water. Air pollutants cover dusts and chemical substances. Non-process dust is generated from open stock piles, coal handling and coke sorting plants. Process dust is generated from battery during coal charging, coke pushing, coke transfer to quenching towers and coke dry quenching, if provided. Along with process dusts, chemicals like hydrogen sulphide, sulphur dioxide, carbon monoxide, pyridine bases, aromatic hydrocarbons, phenols, ammonia, naphthalene, carbon disulphide, 3, 4 benzopyrene, hydrocyanic acid and other compounds are generated.

Non-process dust during coal handling and coke sorting are controlled by providing dust extraction systems. Due to explosive nature of coal dust, utmost precautions are to be taken while selecting a dry dust catching plant. Wet scrubbers are safe, but the problem is generation of effluents which need to be treated. Bag filters of spark proof type are also installed. Dust suppression systems by spraying water at the source with or without additives and dry fog systems have become popular. However, it has limitations that it cannot be sprayed when the material is hot. Dust suppression systems are most useful for open stock piles where dust extraction systems cannot be installed.

Process dust during coke pushing along with fumes can be extracted by specially designed moving hoods located over guide car and quenching cars connected to stationary land based pollution control equipment, which is fabric filter with section to catch tar in the fume. The smoke and fumes produced during the pushing of red hot coke contains a huge amount of coke dust (estimated at 11% of the total pollution in the coke oven). Land-based pushing emission control systems mitigate this pollution. It consists of three parts: (1) a large gas

suction hood fixed on the coke guide car and moving with the coke guide, sending fumes to the coke side dust collecting duct; (2) the dust collection duct; and (3) the final equipment for smoke purification on the ground (ground piping, accumulator cooler, pulse bag dust collector, silencer, ventilation unit, stack, *etc.*). The large amount of paroxysmal high-temperature smoke produced during coke discharging is collected under the hot float fan into the large gas suction hood installed in the coke guide car, and enters the dust collection duct through the other equipment.

The air is dissipated into the atmosphere after purification by the pulse dust collector and after being cooled by the accumulator cooler. The total de-dusting system is controlled by PLC.

Process dust and fume during coal charging emitting through charging lids can be controlled by creating negative pressure in the battery during coal charging. This is done by HPALA systems. The HPALA system is effective for controlling charging emissions in coke oven batteries. In this system, the ammoniacal liquor, which is a byproduct in the coke oven, is pressurized to about 35-40 bar and injected through special nozzles provided in the gooseneck at the time of charging. This creates sufficient suction inside the oven, thereby retaining pollutants from being released into the atmosphere. The system consists of high-pressure multistage booster pumps, sturdy pipe-work, specially designed spray nozzles, suitable valves and control instruments.

Chemical substances leaking from battery can be controlled only by reducing leakages. It is practically impossible to locate suction hoods from various leaking parts of the battery like doors, lids, off-takes, *etc.*, when these are opened or when these leak. As such, coke oven leaking doors can be a major source of pollution. With the advent of recovery type ovens, the design of oven doors has gone through a process of evolution, beginning from luted doors to the present generation self-regulating zero-leak doors. The important features of the leak-proof door include:

- a thin stainless steel diaphragm with a knife edge as a sealing frame built-in between the door body and the brick retainer,
- spring loaded regulation on the knife edge for self-sealing,
- provision for air cooling of the door body, and
- large size gas canals for easier circulation of gas inside oven.

The wastewater effluents contain various organic compounds such as phenols, ammonia and cyanide. These can be treated in a BOD plant through microorganisms.

Waste minimization and pollution prevention in by – product plant

Usage of caustic soda rather than lime in the ammonia still; though more costly, it minimises sludge formation, reduces down time due to scaling problems, and may solve disposal problems.

- Indirect cooling of the coke oven gas to eliminate any contact of the process water with pollutants in the coke oven gas with the exception of flushing liquor.
- Elimination of the recovery of naphthalene and the naphthalene sump.
- The use of an indirect type system for light oil recovery eliminates process waste water steams since no water comes into contact with the gas, the wash oil, the light oil or the final cooler.

- All pumping stations, oil storage tanks and oil transfer points should be located on impervious, dyked pads with the pad effluent directed to the waste ammonia liquor steam for treatment in order to prevent contamination of ground water.
- The wet oxidation sulfur removal processes for coke oven gas has created highly contaminated waste water streams. Alternative processes like Zimpro Modified Wet Air Oxidation Process, the Dofasco Fixed Salts Recovery Process, or the Nippon Steel HIROHAX process exists.
- Tar by products should be recycled in-plant after processing (*e.g.*, for use as a fuel) or sold as a by-product.
- The sludge generated by the biological treatment system can be recycled to the coke oven.
- Tar decanter sludge can be circulated through a solvent grinding pump and then sprayed onto the coal prior to charging into oven.

b) Non-recovery type coke oven battery

The pollution problem from such batteries are low due to the fact that the batteries work under slight negative pressure unlike recovery type batteries, which work under slight positive pressure. As such, emission of pollutants from battery is eliminated. Also, as the COG is completely combusted inside the battery, organic pollutants like PAH are fully broken down. As there is no by-product plant, liquid effluents and a BOD plant are avoided. Solid wastes are completely avoided as there are no crude tar and benzol involved.

Environmental, occupational health and safety problems and mitigation measures for non-recovery beehive type batteries include:

- Battery being charged manually from top while it is still hot causes inhalation of emissions. Coal charging may be mechanized for safe guarding health of workers.
- Manual jobs like – pushing and pulling of coke on wharf after quenching and water spraying using hose pipes – cause health and safety problems due to inhalation of carcinogenic fumes. Mechanization of pushing, pulling and spraying can avoid workers' exposure to heat and steam.
- Combusted coke oven gas is often let off without effective cleaning of dust and fumes. High efficiency battery cyclones with exhaust fans may have pollution problems.
- Coal handling and coke sorting plants are usually without effective dedusting systems. Dust and fume extraction systems at transfer points can avoid air pollution.
- Foundry industry requires coke and same is catered by the small beehive batteries. Tiny size and lack of technological updations are the prevailing causes for pollution from the beehive batteries. However, these tiny beehive plants shall also update their technological provisions in order to meet the desired norms *i.e.*:
 - particulate emissions - 150 mg/m³
 - Work zone norm of 10 mg/m³ for dust

3.3.3 Best operating practices

The industry may initiate the following clean technologies/measures to improve the performance of industry towards production, energy, environment and occupational health and safety.

- Mechanisation of operations to prevent exposure to heat and inhalation of emissions such as battery charging from top, coke pushing, pulling and spray of water by hose pipes.
- Providing exhaust fans, high efficiency battery cyclones, discharging combusted coke oven gas after effective cleaning.
- Effective dedusting of coal handling & coke sorting plants and providing dust & fume extraction systems at transfer points.
- Installation of continuous stack monitoring system and its calibration in major stacks and setting up of online ambient air quality monitoring stations
- Charge of tar sludge/ETP sludge to coke oven
- Operating CO-BP ETP efficiently to achieve the notified effluent discharge standards
- Implementing rainwater harvesting
- Efficient usage of existing pollution control equipment to keep proper record of run hours, failure time and efficiency
- Reduction of Green House Gases by:
 - Reduction in power consumption
 - Use of by-products gases for power generation
 - Promotion of energy optimization technology including energy audit
- To set targets for resource conservation such as raw material, energy and water consumption to match International Standards.
- Upgrading the monitoring and analysis facilities for air and water pollutants. Also to impart elaborate training to the manpower so that realistic data is obtained in the environmental monitoring laboratories.
- To Improve overall house keeping.

3.4 Summary of Applicable National Regulatory Requirements

3.4.1 General description of major statutes

A compilation of legal instruments which are applicable for coke oven plants is provided as **Annexure I**.

3.4.2 General standards for discharge of environmental pollutants

General standards for discharge of environmental pollutants as per CPCB are given in **Annexure II**.

3.4.3 Industry specific standards

Coke oven plants (by product recovery type), for the existing entries, the following entries shall be substituted as given in the following table.

Table 3-6: Coke Oven Plants (By Product Recovery Type)

	New Batteries (at Green Field Site)	Rebuild Batteries	Existing Batteries
Fugitive Visible Emissions			
(a) Leakage from door	5 (PLD)*	10 (PLD)*	10 (PLD)*
(b) Leakage from charging lids	1 (PLL)*	1 (PLL)*	1 (PLL)*
(c) Leakage from AP Covers	4 (PLO)*	4 (PLO)*	4 (PLO)*
(d) Charging emission (second/charge)	16 (with HPLA)*	50 (with HPLA)*	75
Stack Emission of Coke Oven			
(a) SO ₂ (mg/Nm ³)	800	800	800
(b) NO _x (mg/Nm ³)	500	500	500
(c) SPM (mg/Nm ³)	50	50	50
(d) SPM emission during charging- for stamp charging batteries (stack emission mg/Nm ³)	25	25	25
(e) SPM emission during coke pushing (stack emission) gm/ton of coke	5	5 (applicable to stationary land based system)	-
(f) Sulphur in Coke Oven gas used for heating (mg/Nm ³)	800	-	-
Emission for quenching operation			
(a) Particulate matter gm/tonne of coke produced	50	50	-
Benzo-Pyrene (BaP) concentration in work zone air (µg/m³)			
(a) Battery area (top of the battery)	5	5	5
(b) Other units in coke oven plant	2	2	2
(c) Ambient air standards (mg/Nm ³)	10	10	10

For control of emissions and to maintain environmental quality in work zone area, the following guidelines shall be followed, namely:

- (i) New coke oven units shall follow any of the low-emission procedures, such as, coke dry cooling, non-recovery coke-ovens. Indirect quenching process, jumbo coke oven reactor, modified wet quenching system with appropriate environmental controls (e.g. baffles, filtering media, collection and treatment of residual water from quench tower and recycling;

treated effluent conforming to the effluent discharge standards can be used for quenching. Use of untreated process water as quenching water shall not be permissible).

(ii) Effective pollution control measures *e.g.* extensive maintenance and cleaning of oven doors and frame seals, ascension pipes, charging holes and lids and other equipment; On-main charging system (HPLA);

Luting charging holes with clay-suspension; Modified guide/transfer car with emission control system *etc.* shall be used to reduce coal charging and coke pushing emissions.

(iii) During rebuilding or installing new coke oven batteries, the following clean technology and pollution control measures be adopted:

- (a) air-cooled self-sealing doors
- (b) the hydro-jet cleaning system shall be provided for the door and door frame cleaning with a facility of hydro jet pressure of 600 kg/cm²
- (c) the charging should be accomplished with hermetically sealed charging sleeves and screw feeder in charging car. The charging car should also be equipped with magnetic lid lifter, lid and frame cleaning mechanism (applicable to top charging batteries)
- (d) to provide aspiration through high-pressure ammonia liquor (HPLA) injection in goose neck and emission should be transferred directly to gas collecting mains
- (e) water sealed AP covers should be provided
- (f) computerized combustion control and moisture control systems

(iv) In addition to the above the new coke oven batteries, which will be installed after the date of publication of this notification at green field site and rebuild batteries wherever technically feasible should also be equipped to treat their pushing emissions with stationary land-based system with collection hood and wet scrubbing units for gas cleaning.

(v) In the case of existing coke ovens with wet quenching, the new procedures as in (i) and (ii) shall be adopted.

(vi) The fugitive visible emission standards *i.e.* PLD*, PLL* and PLO*, charging emission (second/charge).

Note: Units set up after the publication of this notification shall be treated as new units.

- *HPLA - Aspiration through high pressure liquor injection in gooseneck
- *PLD - Percent leaking doors
- * PLL - Percent leaking lids
- * PLO - Percent leaking off takes

Table 3-7: Coke Oven - Wastewater Discharge Standards

Parameter	Concentration in the effluent when discharged into inland surface water not to exceed, mg/l (except for pH)
pH	5.5 to 9.0
Biochemical oxygen demand (27 °C, 3days)	30
Suspended solids	100

Parameter	Concentration in the effluent when discharged into inland surface water not to exceed, mg/l (except for pH)
Phenolic compounds (As C ₆ H ₅ OH)	5
Cyanides (As CN)	0.2
Oil & grease	10
Ammonical nitrogen (As N)	50

Source: EPA Notification [S.O. 64(E), dt. 18th Jan., 1988]

4. OPERATIONAL ASPECTS OF EIA

Prior environmental clearance process has been revised in the Notification issued on 14th September, 2006, into following four major stages *i.e.*, screening, scoping, public consultation and appraisal. Each stage has certain procedures to be followed. This section deals with all the procedural and technical guidance, for conducting objective-oriented EIA studies, their review and decision-making. Besides, the Notification also classifies projects into Category A, which requires prior environmental clearance from MoEF and Category B from SEIAA/UTEIAA.

Consistency with other requirements

- Clearance from other regulatory bodies is not a prerequisite for obtaining the prior environmental clearance and all such clearances will be treated as parallel statutory requirements.
- Consent for Establishment (CFE) and Prior Environmental Clearance are two different legal requirements a project proponent should acquire. Therefore, these two activities can be initiated and proceeded with simultaneously.
- If a project falls within the purview of CRZ and EIA Notifications, then the project proponent is required to take separate clearances from the concerned Authorities.
- Rehabilitation and Resettlement (R&R) issues need not be dealt under the EIA Notification as other statutory bodies deal with these issues. However, socio-economic studies may be considered while taking environmental decisions.

4.1 Coverage of Coke oven plant under the Purview of Notification

Normally, coke oven plants are inseparable units of an integrated iron and steel plant, which falls under Category A, and are considered while taking composite environmental clearance of the entire new steel plant, irrespective of the capacity of the coke oven plants. However, all the stand alone new coke oven plants including expansion and modernization, whether recovery, non-recovery or beehive types, require separate prior environmental clearance. The technical details given in this TGM applies to both types, *i.e.*, whether a part of an integrated steel plant or a stand alone unit. Based on pollution potential, these stand alone projects are classified into Category A and Category B *i.e.*

- Category A: projects having $\geq 2,50,000$ tonnes/annum coke production capacity
- Category B: projects having $< 2,50,000$, tonnes/annum and $\geq 25,000$ tonnes/annum coke production capacity.

Besides, there is general condition, when it applies, a Category B project will be treated as Category A project. These conditions are discussed in subsequent sections.

The sequence of steps in the process of prior environmental clearance for Category A projects and the Category B projects are shown in Figure 4.1 and Figure 4.2 respectively. Specific duration mentioned in the figures are maximum times that can be taken for processing at various stages. The time for preparation of draft/ summary/ final EIA and time for environmental monitoring is in addition to the duration mentioned for procedural

Operational Aspects of EIA

(clearance) requirements. Each stage in the process of prior environmental clearance for the coke oven plants are discussed in subsequent sections.

In case of expansion or modernization of the developmental activity:

- Any developmental activity, which has an EIA clearance (existing plant), when undergoes expansion or modernization (change in process or technology) with increase in production capacity or any change in product mix beyond the list of products cleared in the issued prior environmental clearance is required to submit new application for EIA clearance.
- Any developmental activity, which is listed in Schedule of the EIA Notification and due to expansion of its total capacity, if falls under the purview of either Category B or Category A, then such developmental activity requires clearance from respective authorities.

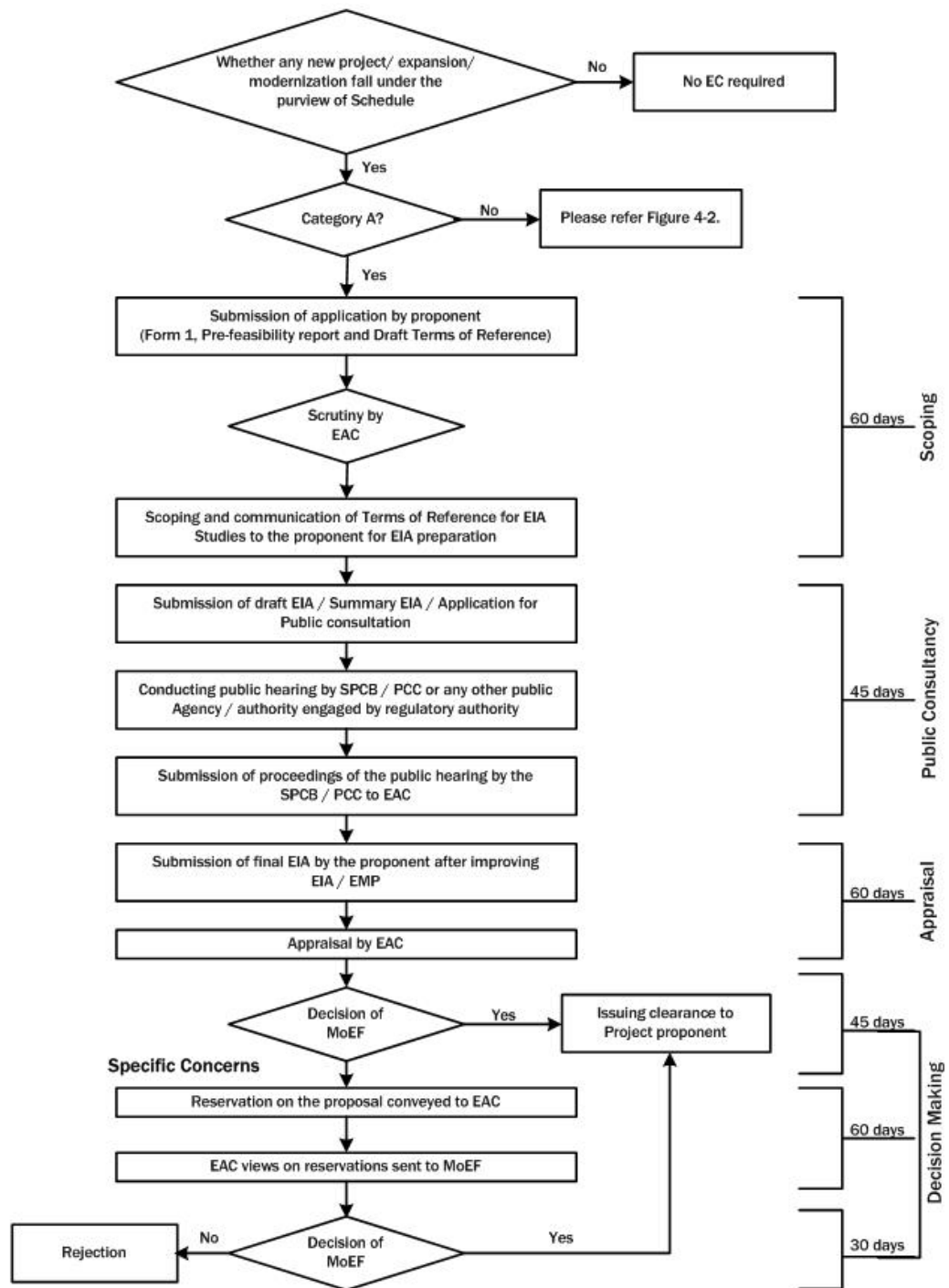

Figure 4-1: Prior Environmental Clearance Process for Activities Falling Under Category A

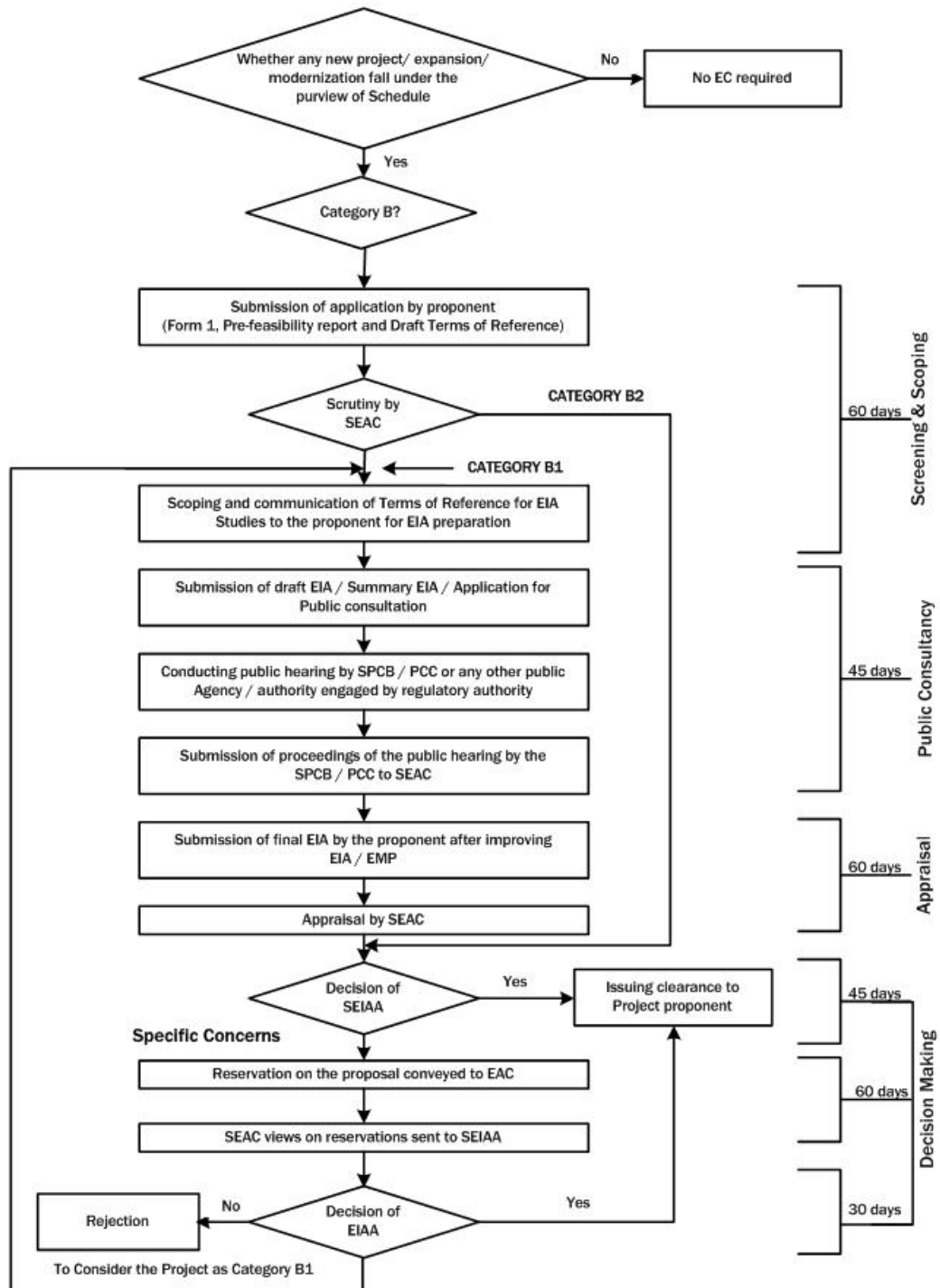

Figure 4-2: Prior Environmental Clearance Process for Activities Falling Under Category B

4.2 Screening

Screening of the project shall be performed at the initial stage of the project development so that proponents are aware of their obligations before deciding on the budget, project design and execution plan.

This stage is applicable only for Category 'B' developmental activity *i.e.* if general conditions are applicable for a Category B project, then it will be treated as Category A project. Besides, screening also refers to the classification of Category B projects into either Category B1 or Category B2. Category B1 projects require to follow all the stages, that are applicable for a Category A project, but are processed at the SEIAA/UTEIAA. Category B2 projects, on the other hand, require neither an EIA nor public consultation.

As per the Notification, classification of Category B projects falls under the purview of the SEAC. This manual provides certain guidelines to the stakeholders for classification of Category B1 and Category B2.

4.2.1 Applicable conditions for Category B projects

General condition

- Any coke oven plant that has a production capacity of <2,50,000 tonnes per annum and $\geq 25,000$ tonnes per annum (usually falling under Category B) will be treated as Category A, if located in whole or in part within 10 km from the boundary of:
 - Protected areas notified under the Wild Life (Protection) Act, 1972
 - Critically polluted areas as notified by the CPCB from time to time
 - Eco-sensitive areas as notified under Section 3 of the E(P) Act, 1986, such as Mahabaleshwar, Panchgani, Matheran, Panchmarhi, Dahanu, Doon valley and
 - Inter-State boundaries and international boundaries – provided that the requirement regarding distance of 10 km of the inter-state boundaries can be reduced or completely done away with by an agreement between the respective States/UTs sharing the common boundary in case the activity does not fall within 10 km of the areas mentioned above
- The SEIAA shall base its decision on the recommendations of a State/UT level EAC for the purpose of prior environmental clearance.
- In absence of a duly constituted SEIAA or SEAC, a Category B project shall be appraised at the Central level *i.e.* at the MoEF.
- The EAC at the State/UT level shall screen the projects or activities in Category B. SEAC shall meet at least once every month.
- If any Category B coke oven project/activity, after proposed expansion of capacity/production or fuel change, falls under the purview of Category A in terms of production capacity, then clearance is required from the Central Government.

4.2.2 Criteria for classification of Category B1 and B2 projects

The classification of Category B projects or activities into B1 or B2 (except the project or activities listed in item 8(b) in the Schedule to the EIA Notification, 2006) will be determined based on whether or not the project or activity requires further environmental studies for preparation of an EIA for its appraisal prior to the grant of prior environmental clearance. The necessity of this will be decided, depending upon the nature and location

specificity of the project, by SEAC after scrutiny of the applications seeking prior environmental clearance for Category B projects or activities.

The projects requiring an EIA report shall be included in Category B1 and remaining projects will fall under Category B2 and will not require an EIA report and public consultation.

Situations which could be considered for Category B2 are:

- **Coke Oven Projects with total capacity less than 25,000 tonnes/annum:** In such cases, the proponent is required to submit Form 1, pre-feasibility report including conceptual plan, one season air quality monitoring data for review and appraisal by the respective Expert Committee.

4.2.3 Application for prior environmental clearance

- The project proponent, after identifying the site and carrying out a pre-feasibility study, is required to apply for the prior environmental clearance using Form 1 given in **Annexure III**. The proponent has to submit the filled in Form 1 along with the pre-feasibility report and draft ToR for EIA studies to the concerned Authority *i.e.* MoEF, Government of India for Category A projects and the SEIAA in case of Category B projects. Please refer subsequent sections for the information on how to fill the Form 1, contents of pre-feasibility report and draft ToR for coke oven plants.
- Prior environmental clearance is required before starting any construction work, or preparation of land on the identified site/project or activity by the project management, except for securing the land.
- If the application is made for a specific developmental activity, which has an inherent area development component as a part of its project proposal and the same project also attracts the construction and area development provisions under 8a and 8b of the Schedule, then the project will be seen as a developmental activity other than 8a and 8b of the Schedule.

4.2.4 Siting guidelines

These are the guidelines, stakeholders may consider while siting the developmental projects, to minimize the associated possible environmental impacts. In some situations, adhering to these guidelines is difficult and unwarranted. Therefore, these guidelines may be kept in the background, as far as possible, while taking the decisions.

Areas preferably be avoided

While siting industries, care should be taken to minimize the adverse impacts of the industries on immediate neighborhood as well as distant places. Some of the natural life sustaining systems and some specific landuses are sensitive to industrial impacts because of the nature and extent of fragility. With a view to protect such sites, the industries may maintain the following distances, as far as possible, from the specific areas listed:

- Ecologically and/or otherwise sensitive areas: Preferably 5 km; depending on the geo-climatic conditions the requisite distance may be decided appropriately by the agency.
- Coastal areas: Preferably ½ km away from high tide line (HTL) and 100m from coastal rivers under influence of tidal action as per CRZ regulations.

- Flood plain of the riverine system: Preferably ½ km away from flood plain or modified flood plain affected by dam in the upstream or flood control systems.
- Transport/Communication System: Preferably ½ km. away from highway and railway line.
- Major settlements (3,00,000 population): Distance from major settlements is difficult to maintain because of urban sprawl. At the time of siting of the industry, if the notified limit of any major settlement is found to be within 50 km from the project boundary, the spatial direction of growth of the settlement for at least a decade must be assessed. Subsequently, the industry may be sited at least 25 km from the projected growth boundary of the settlement. As such, it is difficult for the EIA consultant to do the projection. Hence, Master Plan of the area should be referred, if available.
- Critically polluted areas are identified by MoEF, from time to time. Current list of critically polluted areas is given in **Annexure IV**.

Note:

Ecological and/or otherwise sensitive areas include (i) Religious and Historic Places; (ii) Archaeological Monuments (e.g. identified zone around Taj Mahal); (iii) Scenic Areas; (iv) Hill Resorts; (v) Beach Resorts; (vi) Health Resorts; (vii) Coastal Areas rich in Corals, Mangroves, Breeding Grounds of Specific Species; (viii) Estuaries rich in Mangroves, Breeding grounds of Specific Species; (ix) Gulf Areas; (x) Biosphere Reserves; (xi) National Parks and Sanctuaries; (xii) Natural lakes, Swamps; (xiii) Seismic Zones; (xiv) Tribal Settlements; (xv) Areas of Scientific and Geological Interest; (xvi) Defence Installations, specially those of security importance and sensitive to pollution; (xvii) Border Areas (International) and (xviii) Air Ports.

Pre-requisite: State and Central Governments are required to identify such areas on a priority basis.

General siting factors

In any particular selected site, the following factors must also be recognized.

- No forest land shall be converted into non-forest activity for the sustenance of the industry (Ref: Forest Conversation Act, 1980).
- No prime agricultural land shall be converted into industrial site.
- Land acquired shall be sufficiently large to provide space for appropriate green cover including green belt, around the battery limit of the industry.
- Layout of the industry that may come up in the area must conform to the landscape of the area, without affecting the scenic features of that place.
- Associated township of the industry may be created at a space having physiographic barrier between the industry and the township.

4.3 Scoping for EIA Studies

Scoping exercise is taken up soon after the project contours are defined. The primary purpose of scoping is to identify the concerns and issues which may affect the project decisions. Besides, scoping defines the requirements and boundaries of the EIA study.

Scoping refers to the process by which the EAC, in case of Category ‘A’ projects or activities, and SEAC in case of Category ‘B1’ projects, including applications for expansion and/or modernization of existing projects, determine ToR for EIA studies

addressing all relevant environmental concerns for preparation of an EIA Report for a particular project.

- Project proponent shall submit the application to the concerned authority. The application (Form 1 as given in **Annexure II**) shall be attached with pre-feasibility report and proposed ToR for EIA Studies. The proposed sequence to arrive at the draft ToR is discussed below:
 - Pre-feasibility report provides a summary of project details and also the likely environmental concerns based on the secondary information, which will be availed for filling the Form 1.
 - From pre-feasibility report and the Form 1, valued environmental components (VECs) may be identified for a given project (receiving environment/social components, which are likely to get effected due to the project operations/activities).
 - Once the project details from the pre-feasibility report & Form 1; and VECs are identified, a matrix establishing the interactions which can lead to the effects/impacts could be developed (Qualitative analysis).
 - For each identified possible effect in the matrix, significance analysis could be conducted to identify the impacts, which needs to be further studied (quantitative analysis) in the subsequent EIA studies. All such points will become the part of The draft ToR shall include applicable baseline parameters (refer annexure VII) and impact prediction tools (refer annexure IX) proposed to be applied.
 - The information to be provided in pre-feasibility report, guidelines for filling Form 1 and guidelines for developing draft ToR is summarized in the subsequent sections.
 - Authority consults the respective EAC/SEAC to reply to the proponent. The EAC/SEAC concerned reviews the application form, pre-feasibility report and proposed draft ToR by the proponent and make necessary additions/deletions to make it a comprehensive ToR that suits the statutory requirements for conducting the EIA studies.
- The concerned EAC/SEAC may formulate a sub-committee for a site visit, if considered necessary. The sub-committee will act up on receiving a written approval from the chairperson of EAC/SEAC concerned. Project proponent will facilitate such site visits of the sub-committees.
- EAC/SEAC shall provide an opportunity to the project proponent for presentation and discussions on the proposed project and related issues as well as the proposed ToR for EIA studies. If the State Government desires to present its views on any specific project in the scoping stage, it can depute an officer for the same at the scoping stage to EAC, as an invitee but not as a member of EAC. However, non-appearance of the project proponent before EAC/SEAC at any stage will not be a ground for rejection of the application for the prior environmental clearance.
- If a new or expansion project is proposed in a problem area as identified by the CPCB, then the Ministry may invite representative SEIAA to the EAC to present their views, if any at the stage of scoping.
- The final set of ToR for EIA Studies shall be conveyed to the proponent by the EAC/SEAC within sixty days of the receipt of Form 1 and pre-feasibility report. If the finalized ToR for EIA studies is not conveyed to the proponent within sixty days of the

receipt of Form 1, the ToR suggested by the proponent shall be deemed as the final and will be approved for EIA studies.

- The final ToR for EIA Studies shall be displayed on the website of the MoEF/SEIAA.
- Applications for prior environmental clearance may be rejected by the concerned Authority based on the recommendations by the concerned EAC/SEAC at the scoping stage itself. In case of such rejection, the decision together with reasons for the same shall be communicated to the proponent in writing within sixty days of the receipt of the application.
- The final EIA report and other relevant documents submitted by the applicant shall be scrutinized by the concerned Authority strictly with reference to the approved ToR for EIA studies.

4.3.1 Pre-feasibility report

The pre-feasibility report should include, but not limited to highlight the proposed project information, keeping in view the environmental sensitivities of the selected site, raw material, technology options and its availability. Information required in pre-feasibility report varies from case to case even in the same sector depending upon the local environmental setting within which the plant is located/proposed. However, the environmental information which may be furnished in the pre-feasibility report may include as under:

I. Executive summary

II. Project details: Description of the project including in particular;

- a description of the main characteristics of the production processes, for instance, nature and quantity of materials used,
- an estimate, by type and quantity, of expected residues and emissions (water, air and soil pollution, noise, vibration, light, heat, radiation, *etc.*) resulting from the operation of the proposed project.
- a description of the physical characteristics of the whole project and the land-use requirements during the construction and operational phases

III. Selection of site based on least possible impacts

- An outline of the main alternatives studied by the developer and an indication of the main reasons for this choice, taking into account the environmental effects.

IV. Anticipated impacts based on project operations on receiving environment

- A description of the aspects of the environment likely to be significantly affected by the proposed project, including, in particular, population, fauna, flora, soil, water, air, climatic factors, material assets, including the architectural and archaeological heritage, landscape and the inter-relationship between the above factors.
- A description of the likely significant effects of the proposed project on the environment resulting from:
 - existence of project
 - use of natural resources needed for production
 - emission of pollutants, creation of nuisances and elimination of waste

- project proponent’s description of the forecast methods used to assess the effects on environment

V. Proposed broad mitigation measures which could effectively be internalized as project components to have environmental and social acceptance of the proposed site

- A description of key measures envisaged to prevent, reduce and where possible offset any significant adverse effects on the environment

VI. An indication of any difficulties (technical deficiencies or lack of know-how) encountered by the developer in compiling the required information

Details of the above listed points which may be covered in pre-feasibility report are listed in **Annexure V**.

4.3.2 Guidance for providing information in Form 1

The information given in specifically designed pre-feasibility report for this developmental activity may also be availed for filling Form 1.

Form 1 is designed to help users identify the likely significant environmental effects of proposed projects right at the scoping stage. There are two stages for providing information under two columns:

- First - identifying the relevant project activities from the list given in column 2 of Form 1. Start with the checklist of questions set out below and complete Column 3 by answering:
 - Yes - if the activity is likely to occur during implementation of the project
 - No - if it is not expected to occur
 - May be - if it is uncertain at this stage whether it will occur or not
- Second - For each activity for which the answer in Column 3 is “Yes” the next step is to refer to the fourth column which quantifies the volume of activity which could be judged as significant impact on the local environmental characteristics, and identify the areas that could be affected by that activity during construction /operation / decommissioning of the project. Form 1 requires information within 15 km around the project, whereas actual study area for EIA will be as prescribed by respective EAC/SEAC. Project proponent will need information about the surrounding VECs in order to complete this Form 1.

4.3.3 Identification of appropriate valued environmental components

VECs are components of natural resources and human world that are considered valuable and are likely to be affected by the project activities. Value may be attributed for economic, social, environmental, aesthetic or ethical reasons. VECs represent the investigative focal point for further EIA process. The indirect and/or cumulative effects can be concerned with indirect, additive or even synergistic effects due to other projects or activities or even induced developments on the same environmental components as would be considered direct effects. But such impacts tend to involve larger scale VECs such as within entire region, river basins or watersheds; and, broad social and economic VECs such as quality of life and the provincial economy. Once VECs are identified then appropriate indicators are selected for impact assessments on the respective VECs.

4.3.4 Methods for identification of impacts

There are various factors which influence the approach adopted for the assessment of direct, indirect, cumulative impacts, *etc.* for a particular project. The method should be practical and suitable for the project given the data, time and financial resources available. However, the method adopted should be able to provide a meaningful conclusion from which it would be possible to develop, where necessary, mitigation measures and monitoring. Key points to consider when choosing the method(s) include:

- Nature of the impact(s)
- Availability and quality of data
- Availability of resources (time, finance and staff)

The method chosen should not be complex, but should aim at presenting the results in a way that can be easily understood by the developer, decision maker and the public. A comparative analysis of major impact identification methods is given in Table 4-1:

Table 4-1: Advantages and Disadvantages of Impact Identification Methods

S. No.	Description	Advantages	Disadvantages
Checklists	<ul style="list-style-type: none"> ▪ Annotate the environmental features that need to be addressed when identifying the impacts of activities in the project 	<ul style="list-style-type: none"> ▪ Simple to understand and use ▪ Good for site selection and priority setting ▪ Simple ranking and weighting 	<ul style="list-style-type: none"> ▪ Do not distinguish between direct and indirect impacts ▪ Do not link action and impact ▪ The process of incorporating values can be controversial
Matrices	<ul style="list-style-type: none"> ▪ Identify the interaction between project activities (along one axis) and environmental characteristics (along other axis) using a grid like table ▪ Entries are made in the cells which highlights impact severity in the form of symbols or numbers or descriptive comments 	<ul style="list-style-type: none"> ▪ Link action to impact ▪ Good method for displaying EIA results 	<ul style="list-style-type: none"> ▪ Difficult to distinguish direct and indirect impacts ▪ Significant potential for double-counting of impacts
Networks	<ul style="list-style-type: none"> ▪ Illustrate cause effect relationship of project activities and environmental characteristics ▪ Useful in identifying secondary impacts ▪ Useful for establishing impact hypothesis and other structured science based approaches to EIA 	<ul style="list-style-type: none"> ▪ Link action to impact ▪ Useful in simplified form for checking for second order impacts ▪ Handles direct and indirect impacts 	<ul style="list-style-type: none"> ▪ Can become very complex if used beyond simplified version
Overlays	<ul style="list-style-type: none"> ▪ Map the impacts spatially and display them pictorially ▪ Useful for comparing site and planning alternatives for routing linear developments ▪ Can address cumulative effects ▪ Information incentive 	<ul style="list-style-type: none"> ▪ Easy to understand ▪ Good to display method ▪ Good siting tool 	<ul style="list-style-type: none"> ▪ Address only direct impacts ▪ Do not address impact duration or probability
GIS	<ul style="list-style-type: none"> ▪ Maps the impacts spatially and display them pictorially ▪ Useful for comparing site and 	<ul style="list-style-type: none"> ▪ Easy to understand ▪ Good to display method 	<ul style="list-style-type: none"> ▪ Do not address impact duration or probability ▪ Heavy reliance on

Operational Aspects of EIA

S. No.	Description	Advantages	Disadvantages
	planning alternatives for routing linear developments <ul style="list-style-type: none"> ▪ Can address cumulative effects ▪ Information incentive 	<ul style="list-style-type: none"> ▪ Good siting tool ▪ Excellent for impact identification and analysis 	<ul style="list-style-type: none"> ▪ knowledge and data ▪ Often complex and expensive
Expert System	<ul style="list-style-type: none"> ▪ Assist diagnosis, problem solving and decision making ▪ Needs inputs from user by answering systematically developed questions to identify impacts and determine their mitigability and significance ▪ Information intensive, high investment methods of analysis 	<ul style="list-style-type: none"> ▪ Excellent for impact identification and analysis ▪ Good for experimenting 	<ul style="list-style-type: none"> ▪ Heavy reliance on knowledge and data ▪ Often complex and expensive

The project team made an attempt to construct an impact matrix considering major project activities (generic operations) and stage-specific likely impacts which is given in Table 4-2.

While the impact matrix is each project-specific, Table 4-2 may facilitate the stakeholders in identifying a set of components and phase-specific project activities for determination of likely impacts. However, the location-specific concerns may vary from case to case, therefore, the components even without likely impacts are also retained in the matrix for the location-specific reference.

Table 4-2: Impact Matrix

			PHASE I				PHASE II										PHASE III							
			Pre -Construction				Construction/ Installation										Operation and Maintenance							
1	2	3	4	5	6	7	8	9	10	11	12	13	14	15	16	17	18	19	20	21	22	23		
ENVIRONMENT	Component	Project Activities Parameter/ factor	Detailed Topographic Survey	Land Acquisition	Site Clearing	Burning of wastes, refuse and cleared vegetation	Site Preparation / Change in Topography	Civil works such as earth moving and building of structures including temporary structures	Heavy Equipment operations	Disposal of construction wastes	Generation of sewage	Influx of construction workers	Deforestation	Transportation of material	Installation of equipment	Raw material storage and handling	Crushing and Screening	Battery operations - Charging, pushing and quenching	Coke piling and loading	By-products recovery	Wastewater discharge	Solid and Hazardous waste management		
Physical	Soil	Erosion Risks					*						*											
		Contamination								*								*					*	
		Soil Quality			*				*									*				*	*	
	Resources	Fuels/ Electricity													*					*				
		Raw materials							*											*				
		Land especially undeveloped or agricultural land		*						*														
	Water	Water																		*				
		Interpretation or Alteration of River Beds						*							*									
		Alteration of surface run-off and interflow			*			*	*															
		Water quality							*		*						*					*	*	
	Air	Temperature																						
		Air quality																					*	
		Noise				*			*	*					*		*	*	*	*	*	*	*	*
	Biological	Terrestrial Flora	Climate		*			*	*						*	*		*						
Effect on grass & flowers						*								*				*		*				
Effect on trees & shrubs					*			*			*			*							*	*	*	*

Operational Aspects of EIA

			PHASE I				PHASE II										PHASE III						
			Pre -Construction				Construction/ Installation										Operation and Maintenance						
1	2	3	4	5	6	7	8	9	10	11	12	13	14	15	16	17	18	19	20	21	22	23	
Social	Aquatic Biota	Effect on farmland			*		*						*								*		
		Endangered species			*		*				*											*	*
		Habitat removal			*		*							*								*	
		Contamination of habitats			*		*																
		Reduction of aquatic biota			*		*					*											
		Terrestrial Fauna	Fragmentation of terrestrial habitats			*		*															*
		Disturbance of habitats by noise or vibration			*		*							*									
		Reduction of Biodiversity			*		*											*					
	Economy	Creation of new economic activities	*										*			*					*		
		Commercial value of properties											*				*						
		Conflict due to negotiation and/ compensation payments		*																			
		Generation of temporary and permanent jobs											*		*	*	*	*	*	*	*	*	*
		Effect on crops			*			*				*										*	
		Reduction of farmland productivity		*																		*	
	Income for the state and private sector																		*				
	Savings in foreign currency for the state																						
Education	Training in new technologies	*														*	*	*	*	*	*	*	
	Training in new skills to workers	*									*				*		*		*		*		
Public Order	Political Conflicts		*																		*	*	
	Unrest, Demonstrations & Social conflicts		*								*										*	*	
Infrastructure and Services	Conflicts with projects of urban, commercial or Industrial development	*						*														*	

Operational Aspects of EIA

			PHASE I				PHASE II										PHASE III						
			Pre -Construction				Construction/ Installation										Operation and Maintenance						
1	2	3	4	5	6	7	8	9	10	11	12	13	14	15	16	17	18	19	20	21	22	23	
	Security and Safety	Increase in Crime								*													
		Accidents								*					*	*							*
	Health				*																		
	Cultural	Land use			*		*										*			*		*	*
		Recreation															*	*		*		*	*
		Aesthetics and human interest									*			*			*	*		*		*	*
		Cultural status																					*

Note:

1. The above table represents a model for likely impacts, which will have to be arrived case-to-case basis considering VECs and significance analysis (Ref Section 2.9).
2. Project activities are shown as indicative. However, in Form 1 (application for EIA Clearance), for any question for which answer is 'Yes', then the corresponding activity shall reflect in project activities. Similarly 'parameters'/'factors' will also be changed within a component in order to reflect the target species of prime concern in the receiving local environment.

4.3.5 Testing the Significance of Impacts

The following set of conditions may be used as the checklist for testing the significance of the impacts and also to provide information in Column IV of Form 1.

- Will there be a large change in environmental conditions?
- Will new features be out-of-scale with the existing environment?
- Will the effect be unusual in the area or particularly complex?
- Will the effect extend over a large area?
- Will there be any potential for trans-frontier impact?
- Will many people be affected?
- Will many receptors of other types (fauna and flora, businesses, facilities) be affected?
- Will valuable or scarce features or resources be affected?
- Is there a risk that environmental standards will be breached?
- Is there a risk that protected sites, areas, features will be affected?
- Is there a high probability of the effect occurring?
- Will the effect continue for a long time?
- Will the effect be permanent rather than temporary?
- Will the impact be continuous rather than intermittent?
- If it is intermittent will it be frequent rather than rare?
- Will the impact be irreversible?
- Will it be difficult to avoid, or reduce or repair or compensate for the effect?

For each “Yes” answer in column 3, the nature of effects and reasons for it should be recorded in the column 4. The questions are designed so that an “Yes” answer in column 3, will generally point towards the need for analyzing for the significance and requirement for conducting impact assessment for the effect.

4.3.6 Terms of reference for EIA studies

ToR for EIA studies in respect of the coke oven plant may include, but not limited to the following:

1. Executive summary of the project – giving a *prima facie* idea of the objectives of the proposal, use of resources, justification, *etc.* In addition, it should provide a compilation of EIA report including EMP and the post-project monitoring plan in brief.

Project description

2. Justification for selecting recovery/non-recovery (beehive) type batteries with the proposed unit size.
3. Land requirement for the project including its break up for various purposes, its availability and optimization.
4. Details of proposed layout clearly demarcating various facilities such as coal storages, coke making, by-product recovery area, *etc* within the plant.
5. Complete process flow diagram describing each unit, its processes and operations, along with material and energy inputs and outputs (material and energy balance).
6. Details of coke oven plant (recovery/non-recovery type) including coal handling, coke oven battery operations, coke handling and preparation.

7. Details on proposed source-specific pollution control schemes and equipments to meet the national standards.
8. Details on requirement of raw materials, its source and storage at the plant. An agreement for the supply of the coal for the proposed plant.
9. Details on requirement of energy and water along with its source and authorization from the concerned department. Location of water intake and outfall points (with coordinates) and these locations should be selected based on modeling studies. Details of modeling and the results obtained.
10. Details on water balance including quantity of effluent generated, recycled & reused. Efforts to minimize effluent discharge and to maintain quality of receiving water body.
11. Details of the proposed methods of water conservation and recharging.
12. Details of effluent treatment plant, inlet and treated water quality with specific efficiency of each treatment unit in reduction in respect of all concerned/regulated environmental parameters.
13. Sources of emissions, adequacy of control measures and monitoring protocol.
14. Details on composition, generation and utilization of waste/fuel gases from coke oven plant – mass balance sheet.
15. Management plan for solid/hazardous waste generation, storage, utilization and disposal.
16. Details of waste/scrap handling
17. Details of sources of hazardous waste generation, handling & disposal of hazardous wastes generated.
18. Details regarding infrastructure facilities such as sanitation, fuel storage, restroom, *etc.* to the workers during construction and operation phase.
19. In case of expansion of existing industries, remediation measures adopted to restore the environmental quality if the groundwater, soil, crop, air, *etc.*, are affected and a detailed compliance to the prior environmental clearance/consent conditions.
20. Any litigation pending against the project and /or any direction /order passed by any Court of Law related to the environmental pollution and impacts in the last two years, if so, details thereof.

Description of the environment

21. The study area shall be up to a distance of 10 km from the boundary of the proposed project site.
22. Location of the project site, township and nearest villages with distances from the site to be demarcated on a toposheet (1: 50000 scale).
23. Topography of the study area.
24. Land use based on satellite imagery including location of specific sensitivities such as residential, national parks / wildlife sanctuary, villages, industries, all ecologically sensitive areas, *etc.* for the study area.
25. Demography details of all the villages falling within study area.
26. Baseline data to be collected from the study area w.r.t. different components of environment viz. air, noise, water, land, biology and socio-economics (please refer Section 4.4.2 for guidance for assessment of baseline components and identify

attributes of concern). Actual monitoring of baseline environmental components shall be strictly according to the parameters prescribed in the ToR after considering the proposed coverage of parameters by the proponent in draft ToR and shall commence after finalization of ToR by the competent Authority.

27. Geological features and geo-hydrological status of the study area at solid waste dump zone.
28. Surface water quality of nearby water sources and other surface drains.
29. Details on ground water quality.
30. Details on water quality for parameters pH, temperature, COD, Biochemical oxygen demand (27°C, 3 days), TDS*, Suspended solids*, Phenolic compounds (As C₆H₅OH)*, Cyanides (As CN)*, Oil & grease*, Ammonical nitrogen (As N)*, chlorides*, sulphides*, *etc.* (* - As applicable)
31. Details on existing ambient air quality and expected, stack and fugitive emissions for SO₂*, NO_x*, PM₁₀*, PM_{2.5}*, O₃*, Pb*, CO*, C₆H₆*, benzo(a)pyrene (BaP)*, *etc.*, and evaluation of the adequacy of the proposed pollution control devices to meet standards for point sources and to meet AAQ standards. (* - As applicable)
32. Proposed pollution control devices for small beehive batteries to meet particulate emission norms of 150 mg/m³ and work zone norms of 10 mg/m³ for dust.
33. The air quality contours may be plotted on a location map showing the location of project site, habitation nearby, sensitive receptors, if any and wind roses.
34. Details on noise levels at sensitive/commercial receptors.
35. Site-specific micro-meteorological data including mixing height as per IMD publication.
36. Ecological status (terrestrial and aquatic) of the study area such as habitat type and quality, species, diversity, rarity, fragmentation, ecological linkage, age, abundance, *etc.*
37. If any incompatible land use attributes fall within the study area, proponent shall describe the sensitivity (distance, area and significance) and propose the additional points based on significance for review and acceptance by the EAC/SEAC. Incompatible land use attributes include:
 - Public water supply areas from rivers/surface water bodies, from ground water
 - Scenic areas/tourism areas/hill resorts
 - Religious places, pilgrim centers that attract over 10 lakh pilgrims a year
 - Protected tribal settlements (notified tribal areas where industrial activity is not permitted)
 - Monuments of national significance, World Heritage Sites
 - Cyclone, Tsunami prone areas (based on last 25 years);
 - Airport areas
 - Any other feature as specified by the State or local government and other features as locally applicable, including prime agricultural lands, pastures, migratory corridors, *etc.*
38. If ecologically sensitive attributes fall within the study area, proponent shall describe the sensitivity (distance, area and significance) and propose the additional points based on significance for review and acceptance by the EAC/SEAC. Ecological sensitive attributes include:
 - National parks

- Wild life sanctuaries Game reserve
 - Tiger reserve/elephant reserve/turtle nesting ground
 - Mangrove area
 - Wetlands
 - Zoological gardens
 - Reserved and protected forests
 - Protected forests
 - Any other closed/protected area under the Wild Life (Protection) Act, 1972,
 - Any other eco-sensitive areas
39. If the location falls in Valley, specific issues connected to the natural resources management shall be studied and presented.
40. If the location falls in CRZ area: A CRZ map duly authenticated by one of the authorized agencies demarcating LTL, HTL, CRZ area, location of the project and associate facilities w.r.t. CRZ, coastal features such as mangroves, if any.
- Provide the CRZ map in 1:10000 scale in general cases and in 1:5000 scale for specific observations.
 - Proposed site for disposal of dredged material and environmental quality at the point of disposal/impact areas.
 - Fisheries study should be done w.r.t. Benthos and Marine organic material and coastal fisheries.

Anticipated environmental impacts and mitigation measures

41. Anticipated generic environmental impacts due to the project are indicated in Table 4-2, which may be evaluated for significance and based on corresponding likely impacts VECs may be identified. Baseline studies may be conducted for all these concerned VECs and likely impacts will have to be assessed for their magnitude in order to identify mitigation measures (please refer Chapter 4 of the manual for guidance).
42. Tools as given in Section 4.4.3 may be referred for the appropriate assessment of environmental impacts and same may be submitted in draft ToR for consideration and approval by EAC/SEAC.
43. While identifying the likely impacts, also include the following for analysis of significance and required mitigation measures:
- impacts due to transport of raw materials and end/finished products
 - impacts due to fugitive emissions, stack emissions, emissions due to quenching and other emissions on ambient air quality
 - impacts due to battery operations
 - impacts due to wastewater discharge
 - impact due to project activities on health of workers/nearby residents
 - impacts due to noise
 - impact on local infrastructure due to project and any other project-specific significant impacts
44. Proposed odour control measures
45. In case of likely impact from the proposed facility on the surrounding reserve forests, conservation plan for wild fauna in consultation with the State Forest Department.
46. For identifying the mitigation measures, please refer Chapter III for source control and treatment. Besides typical mitigation measures which may also be considered are discussed in Table 4-5. These mitigation measures may bring the likely impacts into

acceptable level as per notified standards. Some of the areas, which require specific mitigation measures are as follows:

- Proposed unit wise air pollution control measures
 - Proposed mitigation measures to control the secondary emissions
 - Proposed measures to control use and impact on groundwater
 - Recovering benzene from COG, incase of recovery type coke production
 - Recovering sulfur from coke oven gas
 - Recycling solid wastes
 - Reducing ammonia content in ammonia liquor
 - Proposed measures for occupational health and safety of the workers
 - Proposed noise control measures during project activities
 - Scheme for storm water management from site and surroundings
47. Action plan for green cover development including the details of species, width of plantation, planning schedule, *etc.* in accordance to CPCB-published guidelines
48. Details on surface as well as roof top rainwater harvesting and groundwater recharge.
49. Action plan for solid/hazardous waste generation, storage, utilization and disposal particularly tar and sludge from by-product recovery plant, dust from APCS *etc.*
50. Training programs to employers for regulated areas regarding occupational safety and health hazards, exposure to coke oven emissions, purpose, proper use and limitations of respiratory protective devices, *etc.*

Analysis of alternative resources and technologies

51. Comparison of alternate sites considered and the reasons for selecting the proposed site. Conformity of the site with the prescribed guidelines in terms of CRZ, river, highways, railways, *etc.*
52. Details of clean technologies as elaborated in Chapter 3 of this manual or any other improved technologies.
53. Details on proposed recovery options.

Environmental monitoring program

54. Monitoring at source/control equipment – coal handling, coal transportation, battery operations, coke handling and preparation, air pollution control systems, *etc.*
55. Monitoring of pollutants at receiving environment (ambient and work zone) for all the appropriate notified parameters – air quality, groundwater, surface water, *etc.*, during operational phase of the project.
56. Stack and fugitive emissions may be monitored for SPM, PM10, PM2.5, SO2, NOx, HC, CO, acid mist, VOC and BaPs (at ground level and at battery top) and evaluation of the adequacy of the proposed pollution control devices to meet gaseous emissions and dust fall data with heavy metal analysis.
57. Identifying the regulated areas in the plant and regular monitoring of these areas for concerned pollutants - topside and its machinery, pushside and its machinery, coke side and its machinery, and the battery ends; the wharf; and the screening station;
58. An action plan to control and monitor PLD (percent leaking oven doors), PLL (percent leaking lids), PLA, PLO (percent leaking off gas) coal charging visible emission period, secondary fugitive emissions during coke discharge.

59. Specific programme to monitor occupational, safety and health protection of workers.
60. Monitoring of carbon foot print
61. Details of monitoring network proposed for regulatory compliance and to assess the possible residual impacts on VECs.
62. Details of in-house monitoring capabilities and the recognized agencies, if proposed for regular monitoring.

Additional studies

63. Details on risk assessment and damage control during different phases of the project and proposed safeguard measures.
64. Details on socio-economic development activities such as commercial property values, generation of jobs, education, social conflicts, cultural status, accidents, *etc.*
65. Proposed plan to handle the socio-economic influence on the local community. The plan should include quantitative dimension as far as possible.
66. Details on compensation package for the people affected by the project, considering the socio-economic status of the area, homestead oustees, land oustees, and landless labourers.
67. Points identified in the public hearing and commitment of the project proponent to the same. Detailed action plan addressing the issues raised, and the details of necessary allocation of funds.
68. Details on plan for corporate social responsibility including the villages, population spread, SC/ST/backward communities, upgradation of existing schools, establishing new schools with facilities (such as laboratories, toilets, *etc.*), link roads, community halls, primary health facilities, health camps, *etc.*

Environmental management plan

69. Administrative and technical organizational structure to ensure proposed post-project monitoring programme for approved mitigation measures.
70. EMP devised to mitigate the adverse impacts of the project should be provided along with item-wise cost of its implementation (Capital and recurring costs).
71. Allocation of resources and responsibilities for plan implementation.
72. Details of the emergency preparedness plan and on-site and off-site disaster management plan.

Note:

Above points shall be adequately addressed in the EIA report at corresponding chapters, in addition to the contents given in the reporting structure (Table: 4-6)

4.4 Environmental Impact Assessment

The generic approach for accomplishing EIA studies is shown in Figure 4.3. Each stage is discussed, in detail in subsequent sections.

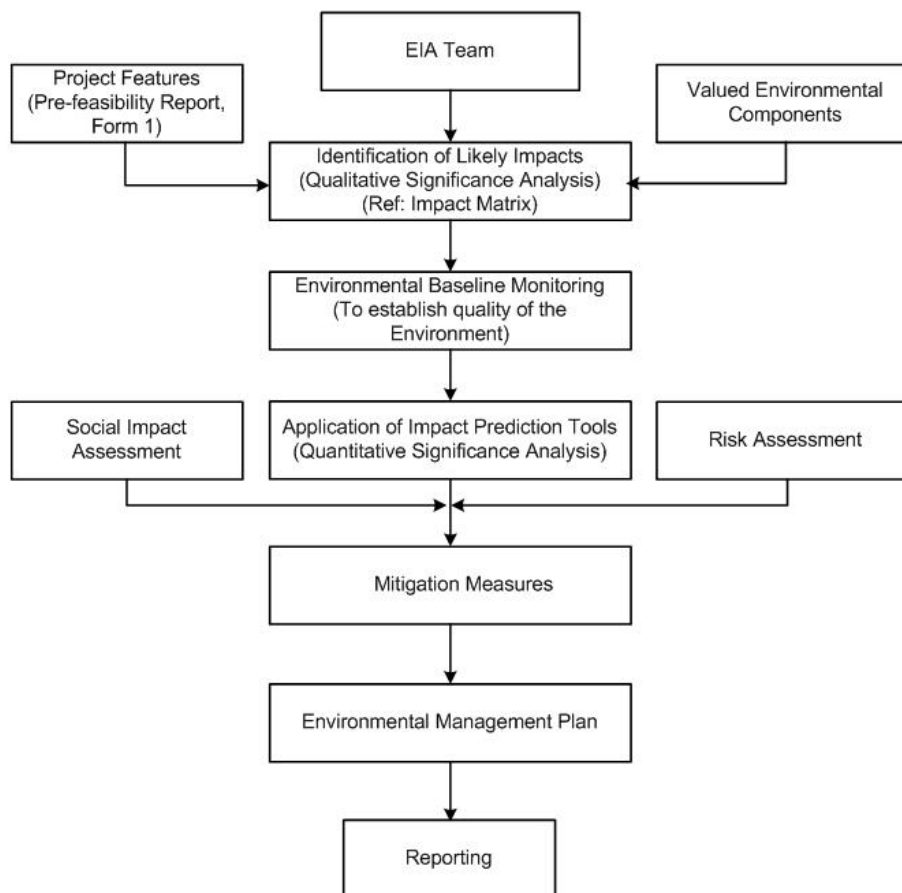

Figure 4-3: Approach for EIA Study

4.4.1 EIA team

The success of a multi-functional activity like an EIA primarily depends on constitution of a right team at the right time (preferable at the initial stages of an EIA) in order to assess the significant impacts (direct, indirect as well as cumulative impacts).

The professional Team identified for a specific EIA study should consist of qualified and experienced professionals from various disciplines in order to address the critical aspects identified for the specific project. Based on the nature and the environmental setting, following professionals may be identified for EIA studies:

- Environmental management specialist/regulator
- Organic chemist/chemical engineer
- Thermal engineer
- Air and noise quality specialist
- Occupational health specialist
- Ecologist
- Transportation specialist
- Safety and health specialist
- Social scientist, *etc.*

4.4.2 Baseline quality of the environment

EIA Notification 2006 specifies that an EIA Report should contain a description of the existing environment that would be or might be affected directly or indirectly by the proposed project. Environmental Baseline Monitoring (EBM) is a very important stage of EIA. On one hand EBM plays a very vital role in EIA and on the other hand it provides feedback about the actual environmental impacts of a project. EBM, during the operational phase, helps in judging the success of mitigation measures in protecting the environment. Mitigation measures, in turn are used to ensure compliance with environmental standards, and to facilitate the needed project design or operational changes.

The description of the existing environment should include the natural, cultural, socio-economic systems and their interrelationships. The intention is not to describe all baseline conditions, but to focus the collection and description of baseline data on those VECs that are important and are likely to be affected by the proposed industrial activity.

4.4.2.1 Objective of EBM in EIA context

The term 'baseline' refers to conditions existing before development. EBM studies are carried out to:

- identify environmental conditions which might influence project design decisions (*e.g.*, site layout, structural or operational characteristics);
- identify sensitive issues or areas requiring mitigation or compensation;
- provide input data to analytical models used for predicting effects;
- provide baseline data against which the results of future monitoring programs can be compared.

At this stage of EIA process, the EBM is primarily discussed in the context of first purpose wherein the feedback from EBM programs may be used to:

- determine available assimilative capacity of different environmental components within the designated impact zone and whether more or less stringent mitigation measures are needed; and
- improve predictive capability of EIAs.

There are many institutional, scientific, quality control, and fiscal issues that must be addressed in implementation of an environmental monitoring program. Careful consideration of these issues in the design and planning stages will help avoid many of the pitfalls associated with environmental monitoring programs.

4.4.2.2 Environmental monitoring network design

Monitoring refers to the collection of data through a series of repetitive measurements of environmental parameters (or, more generally, to a process of systematic observation). Design of the environmental quality monitoring programme depends up on the monitoring objectives specified for the selected area of interest. Types of monitoring and network design considerations are discussed in **Annexure VI**.

4.4.2.3 Baseline data generation

List of important physical environmental components and indicators of EBM are given in Table 4-3.

Table 4-3: List of Important Physical Environment Components and Indicators of EBM

Environmental Component	Environmental Indicators
Climatic variables	<ul style="list-style-type: none"> ▪ Rainfall patterns – mean, mode, seasonality ▪ Temperature patterns ▪ Extreme events ▪ Climate change projections ▪ Prevailing wind - direction, speed, anomalies ▪ Relative humidity ▪ Stability conditions and mixing height <i>etc.</i>
Topography	<ul style="list-style-type: none"> ▪ Slope form ▪ Landform and terrain analysis ▪ Specific landform types <i>etc.</i>
Geology	<ul style="list-style-type: none"> ▪ Underlying rock type, texture ▪ Surgical material ▪ Geologic structures (faults, shear zones, <i>etc.</i>) ▪ Geologic resources (minerals) <i>etc.</i>
Coastal dynamics and morphology	<ul style="list-style-type: none"> ▪ Wave patterns ▪ Currents ▪ Shoreline morphology – near shore, foreshore ▪ Sediment – characteristics and transport
Drainage	<ul style="list-style-type: none"> ▪ Surface hydrology ▪ Natural drainage pattern and network ▪ Rainfall runoff relationships ▪ Hydrogeology ▪ Groundwater characteristics – springs, <i>etc.</i>
Soil	<ul style="list-style-type: none"> ▪ Type and characteristics ▪ Porosity and permeability ▪ Sub-soil permeability ▪ Run-off rate ▪ Infiltration capacity ▪ Effective depth (inches/centimeters) ▪ Inherent fertility ▪ Suitability for method of sewage disposal <i>etc.</i>
Water quality	<ul style="list-style-type: none"> ▪ Raw water availability ▪ Water quality ▪ Surface water (rivers, lakes, ponds, gullies) – quality, water depths, flooding areas, <i>etc.</i> ▪ Ground water – water table, local aquifer storage capacity, specific yield, specific retention, water level depths and fluctuations, <i>etc.</i> ▪ Coastal ▪ Floodplains ▪ Wastewater discharges ▪ Thermal discharges ▪ Waste discharges <i>etc.</i>
Air quality	<ul style="list-style-type: none"> ▪ Ambient ▪ Work Zone ▪ Airshed importance ▪ Odour levels

Environmental Component	Environmental Indicators
Noise	<ul style="list-style-type: none"> ▪ Identifying sources of noise ▪ Noise due to traffic/transportation of vehicles ▪ Noise due to heavy equipment operations ▪ Duration and variations in noise over time, <i>etc.</i>
Biological	<ul style="list-style-type: none"> ▪ Species composition of flora and fauna ▪ Flora – type, density, exploitation, <i>etc.</i> ▪ Fauna – distribution, abundance, rarity, migratory, species diversity, habitat requirements, habitat resilience, economic significance, commercial value, <i>etc.</i> ▪ Fisheries – migratory species, species with commercial/recreational value <i>etc.</i>
Landuse	<ul style="list-style-type: none"> ▪ Landuse pattern, <i>etc.</i>

Guidance for assessment of baseline components and attributes describing sampling network, sampling frequency, method of measurement is given in **Annexure VII**.

Infrastructure requirements for EBM

In addition to devising a monitoring network design and monitoring plans/program, it is also necessary to ensure adequate resources in terms of staffing, skills, equipment, training, budget, *etc.*, for its implementation. Besides assigning institutional responsibility, reporting requirements, QA/QC plans and its enforcement capability are essential. A monitoring program that does not have an infrastructural support and QA/QC component will have little chance of success.

Defining data statistics/analyses requirements

The data analyses to be conducted are dictated by the objectives of environmental monitoring program. The statistical methods used to analyze data should be described in detail prior to data collection. This is important because repetitive observations are recorded in time and space. Besides, the statistical methods could also be chosen so that uncertainty or error estimates in the data can be quantified. For *e.g.*, statistical methods useful in an environmental monitoring program include: 1) frequency distribution analysis; 2) analysis of variance; 3) analysis of covariance; 4) cluster analysis; 5) multiple regression analysis; 6) time series analysis; 7) the application of statistical models.

Use of secondary data

The EBM program for EIA can at best address temporal and/or spatial variations limited to a limited extent because of cost implications and time limitations. Therefore analysis of all available information or data is essential to establish the regional profiles. So all the relevant secondary data available for different environmental components should be collated and analyzed.

To facilitate stakeholders, IL&FS Ecosmart Ltd. has made an attempt to compile the list of information required for EIA studies and the sources of secondary data, which are given in **Annexure VIIIA** and **Annexure VIIIB**.

4.4.3 Impact prediction tools

The scientific and technical credibility of an EIA relies on the ability of EIA practitioners to estimate the nature, extent, and magnitude of change in environmental components that may result from project activities. Information about predicted changes is needed for assigning impact significance, prescribing mitigation measures, and designing & developing EMPs and post project monitoring programs. The more accurate the predictions, the more confident the EIA practitioner will be in prescribing specific measures to eliminate or minimize the adverse impacts of development project.

Choice of models/methods for impact predictions in respect to each of air, noise, water, land biological and socio-economic environment are precisely tabulated in **Annexure VIII**.

4.4.4 Significance of the impacts

Evaluating the significance of environmental effects is perhaps the most critical component of impact analysis. The interpretation of significance bears directly on the subsequent EIA process and also during prior environmental clearance on project approvals and condition setting. At an early stage, it also enters into screening and scoping decisions on what level of assessment is required and which impacts and issues will be addressed.

Impact significance is also a key to choosing among alternatives. In total, the attribution of significance continues throughout the EIA process, from scoping to EIS review, in a gradually narrowing “cone of resolution” in which one stage sets up the next. But at this stage it is the most important as better understanding and quantification of impact significance is required.

One common approach is based on determination of the significance of predicted changes in the baseline environmental characteristics and compares these w.r.t regulatory standards, objective criteria and similar ‘thresholds’ as eco-sensitivity, cultural /religious values. Often, these are outlined in guidance. A better test proposed by the CEAA (1995) is to determine if ‘residual’ environmental effects are adverse, significant, and likely (given under). But at this stage, the practice of formally evaluating significance of residual impacts, *i.e.*, after predicting the nature and magnitude of impacts based on before-versus-after-project comparisons, and identifying measures to mitigate these effects is not being followed in a systematic way.

i. Step 1: Are the environmental effects adverse?

Criteria for determining if effects are “adverse” include:

- effects on biota health
- effects on rare or endangered species
- reductions in species diversity
- habitat loss
- transformation of natural landscapes
- effects on human health
- effects on current use of lands and resources for traditional purposes by aboriginal persons
- foreclosure of future resource use or production

ii. Step 2: Are the adverse environmental effects significant?

Criteria for determining ‘significance’ are to judge that the impacts:

- are extensive over space or time
- are intensive in concentration or proportion to assimilative capacity
- exceed environmental standards or thresholds
- do not comply with environmental policies, landuse plans, sustainability strategy
- adversely and seriously affect ecologically sensitive areas
- adversely and seriously affect heritage resources, other landuses, community lifestyle and/or indigenous peoples traditions and values

iii. Step 3: Are the significant adverse environmental effects likely?

Criteria for determining ‘likelihood’ include:

- probability of occurrence, and
- scientific uncertainty

4.5 Social Impact Assessment

Social Impact Assessment (SIA) is an instrument used to analyze social issues and solicit stakeholder views for the design of projects. SIA helps in making the project responsive to social development concerns, including the options that enhance benefits for poor and vulnerable people while mitigating risk and adverse impacts. It analyzes distributional impacts of intended project benefits on different stakeholder groups, and identifies differences in assets and capabilities to access the project benefits.

The scope and depth of SIA should be determined by the complexity and importance of issues studied, taking into account the skills and resources available. SIA should include studies related to involuntary resettlement, compulsory land acquisition, impact of imported workforces, job losses among local people, damage to sites of cultural, historic or scientific interest, impact on minority or vulnerable groups, child or bonded labour, use of armed security guards. However, SIA may primarily include the following:

Description of the socio-economic, cultural and institutional profile

Conduct a rapid review of available sources of information to describe the socio-economic, cultural and institutional interface in which the project operates.

Socio-economic and cultural profile: Describe the most significant social, economic and cultural features that differentiate social groups in the project area. Describe their different interests in the project, and their levels of influence. Explain any specific effects, the project may have on the poor and underprivileged. Identify any known conflicts among groups that may affect project implementation.

Institutional profile: Describe the institutional environment; consider both the presence and function of public, private and civil society institutions relevant to the operation. Are there important constraints within existing institutions *e.g.* disconnect between institutional responsibilities and the interests and behaviors of personnel within those institutions? Or are there opportunities to utilize the potential of existing institutions, *e.g.* private or civil society institutions, to strengthen implementation capacity.

Legislative and regulatory considerations

To review laws and regulations governing the project's implementation and the access of poor and excluded groups to goods, services and opportunities provided by the project. In addition, review the enabling environment for public participation and development planning. SIA should build on strong aspects of legal and regulatory systems to facilitate program implementation and identify weak aspects while recommending alternative arrangements.

Key social issues

SIA provides the baseline information for designing the social development strategy. The analysis should determine what the key social and Institutional issues which affect the project objectives; identify the key stakeholder groups in this context and determine how relationships between stakeholder groups will affect or be affected by the project; and identify expected social development outcomes and actions proposed to achieve those outcomes.

Data collection and methodology

Describe the design and methodology for social analysis. In this regard:

- Build on existing data;
- Clarify the units of analysis for social assessment: intra-household, household level, as well as communities/settlements and other relevant social aggregations on which data is available or will be collected for analysis;
- Choose appropriate data collection and analytical tools and methods, employing mixed methods wherever possible; mixed methods include a mix of quantitative and qualitative methods.

Strategy to achieve social development outcomes

Identify the likely social development outcomes of the project and propose a social development strategy, including recommendations for institutional arrangements to achieve them, based on the findings of the social assessment. The social development strategy could include measures that:

- strengthen social inclusion by ensuring inclusion of both poor and excluded groups and intended beneficiaries in the benefit stream offer access to opportunities created by the project
- empower stakeholders through their participation in design and implementation of the project, their access to information, and their increased voice and accountability (*i.e.* a participation framework); and
- enhance security by minimizing and managing likely social risks and increasing the resilience of intended beneficiaries and affected persons to socioeconomic shocks

Implications for analysis of alternatives

Review the proposed approaches for the project, and compare them in terms of their relative impacts and social development outcomes. Consider what implications the findings of the social assessment might have on those approaches. Should some new components be added to the approach, or other components be reconsidered or modified?

If the SIA and consultation processes indicate that alternative approaches may have better development outcomes, such alternatives should be described and considered, along with the likely budgetary and administrative effects these changes might have.

Recommendations for project design and implementation arrangements

Provide guidance to project management and other stakeholders on how to integrate social development issues into project design and implementation arrangements. As much as possible, suggest specific action plans or implementation mechanisms to address relevant social issues and potential impacts. These can be developed as integrated or separate action plans, for example, as Resettlement Action Plans, Indigenous Peoples Development Plans, Community Development Plans, *etc.*

Developing a monitoring plan

Through SIA process, a framework for monitoring and evaluation should be developed. To the extent possible, this should be done in consultation with key stakeholders, especially beneficiaries and affected people.

The framework shall identify expected social development indicators, establish benchmarks, and design systems and mechanisms for measuring progress and results related to social development objectives. The framework shall identify organizational responsibilities in terms of monitoring, supervision, and evaluation procedures. Wherever possible, participatory monitoring mechanisms shall be incorporated. The framework should establish:

- a set of monitoring indicators to track the progress achieved. The benchmarks and indicators should be limited in number, and should combine both quantitative and qualitative types of data. The indicators for outputs to be achieved by the social development strategy should include indicators to monitor the process of stakeholder participation, implementation and institutional reform
- indicators to monitor social risk and social development outcomes; and indicators to monitor impacts of the project's social development strategy. It is important to suggest mechanisms through which lessons learned from monitoring and stakeholder feedback can result in changes to improve the operation of the project. Indicators should be of such a nature that results and impacts can be disaggregated by gender and other relevant social groups
- define transparent evaluation procedures. Depending on context, these may include a combination of methods, such as participant observation, key informant interviews, focus group discussions, census and socio-economic surveys, gender analysis, Participatory Rural Appraisal (PRA), Participatory Poverty Assessment (PPA) methodologies, and other tools. Such procedures should be tailored to the special conditions of the project and to the different groups living in the project area; Estimate resource and budget requirements for monitoring and evaluation activities, and a description of other inputs (such as institutional strengthening and capacity building) needed to carry it out.

4.6 Risk Assessment

Industrial accidents results in great personal and financial loss. Managing these accidental risks in today's environment is the concern of every industry including coke oven plants,

because either real or perceived incidents can quickly jeopardize the financial viability of a business. Many facilities involve various manufacturing processes that have the potential for accidents which may be catastrophic to the plant, work force, environment, or public.

The main objective of the risk assessment study is to propose a comprehensive but simple approach to carry out risk analysis and conducting feasibility studies for industries and planning and management of industrial prototype hazard analysis study in Indian context.

Risk analysis and risk assessment should provide details on Quantitative Risk Assessment (QRA) techniques used world-over to determine risk posed to people who work inside or live near hazardous facilities, and to aid in preparing effective emergency response plans by delineating a DMP to handle onsite and offsite emergencies. Hence, QRA is an invaluable method for making informed risk-based process safety and environmental impact planning decisions, as well as being fundamental to any facility-siting decision-making. QRA whether, site-specific or risk-specific for any plant is complex and needs extensive study that involves process understanding, hazard identification, consequence modeling, probability data, vulnerability models/data, local weather and terrain conditions and local population data. QRA may be carried out to serve the following objectives.

- Identification of safety areas
- Identification of hazard sources
- Generation of accidental release scenarios for escape of hazardous materials from the facility
- Identification of vulnerable units with recourse to hazard indices
- Estimation of damage distances for the accidental release scenarios with recourse to Maximum Credible Accident (MCA) analysis
- Hazard and Operability studies (HAZOP) in order to identify potential failure cases of significant consequences
- Estimation of probability of occurrences of hazardous event through fault tree analysis and computation of reliability of various control paths
- Assessment of risk on the basis of above evaluation against the risk acceptability criteria relevant to the situation
- Suggest risk mitigation measures based on engineering judgement, reliability and risk analysis approaches
- Delineation / up-gradation of DMP
- Safety Reports: with external safety report/ occupational safety report.

The risk assessment report may cover the following in terms of the extent of damage with resource to MCA analysis and delineation of risk mitigations measures with an approach to DMP.

- Hazard identification – identification of hazardous activities, hazardous materials, past accident records, *etc.*
- Hazard quantification – consequence analysis to assess the impacts
- Risk Presentation
- Risk Mitigation Measures
- DMPs

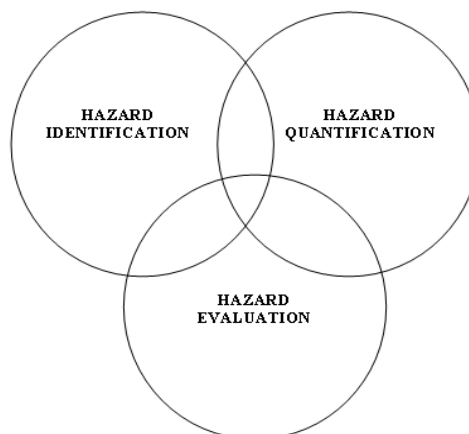

Figure 4-4: Risk Assessment – Conceptual Framework

Methods of risk prediction should cover all the design intentions and operating parameters to quantify risk in terms of probability of occurrence of hazardous events and magnitude of its consequence. Table 4-4 shows the predictive models for risk assessment.

Table 4-4: Choice of Models for Impact Predictions: Risk Assessment

Name	Application	Remarks
EFFECT	Consequence Analysis for Visualization of accidental chemical release scenarios & its consequence	Heat load, press wave & toxic release exposure neutral gas dispersion
WHAZAN	Consequence Analysis for Visualization of accidental chemical release scenarios & its consequence	
DEGADIS	Consequence Analysis for Visualization of accidental chemical release scenarios & its consequence	Dense gas dispersion
HAZOP and Fault Tree Assessment	For estimating top event probability	Failure frequency data is required
Pathways reliability and protective system hazard analysis	For estimating reliability of equipments and protective systems	Markov models
Vulnerability Exposure models	Estimation of population exposure	Uses probit equation for population exposure
F-X and F-N curves	Individual / Societal risks	Graphical Representation

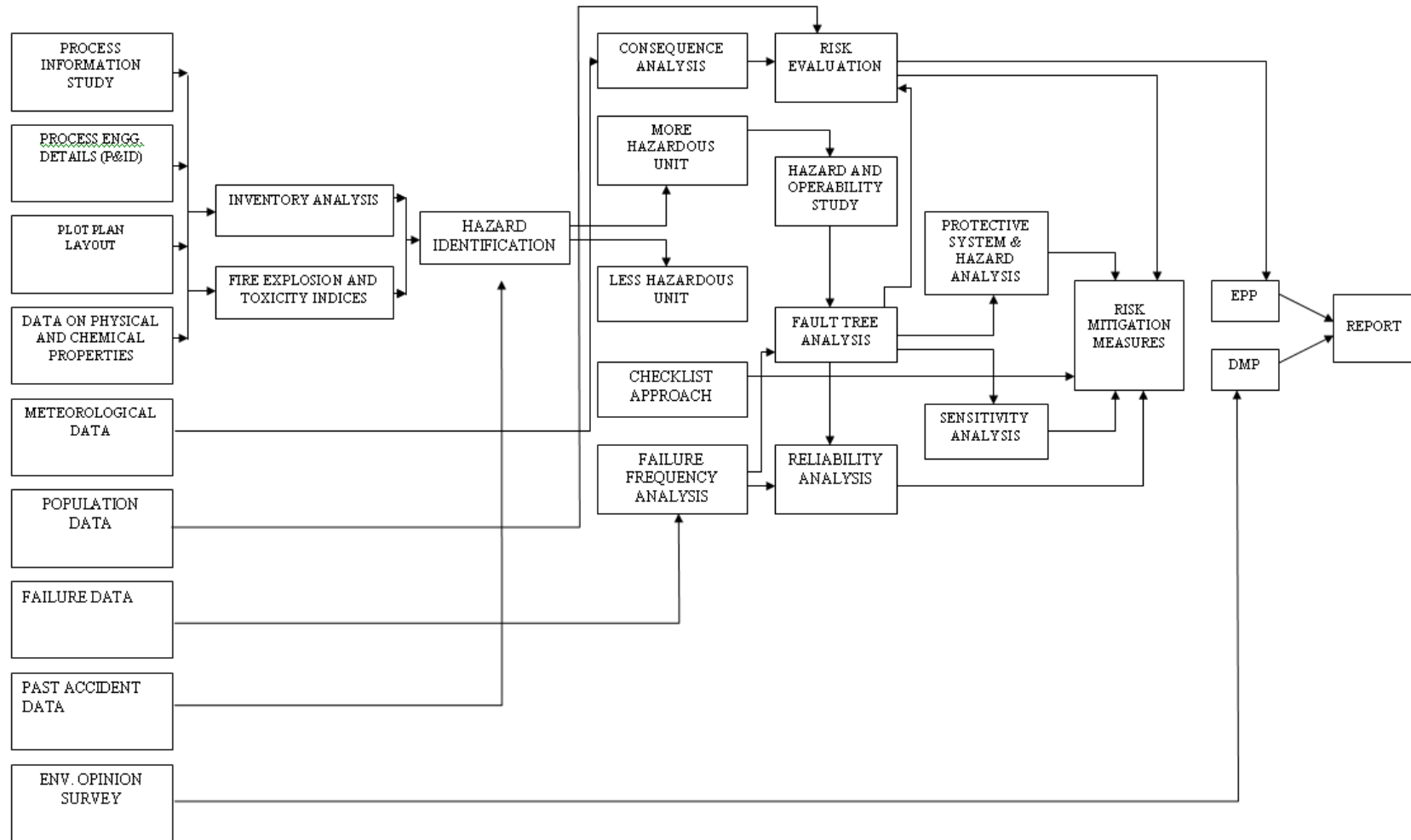

Figure 4-5: Comprehensive Risk Assessment - At a Glance

4.6.1 Storage & Handling of hazardous materials

Both hazardous and non-hazardous waste generated within the project facility shall be temporarily accommodated in appropriate units placed within the project facility built/made in line with the safety, health and environmental standards.

The size of these temporary units would depend on the quantity and type of hazardous waste materials like asbestos, PCB, oils, fuels, *etc.*, with appropriate storage capacities placed in the project facility in compliance with the Hazardous Waste Management and Handling Rules. In case of radioactive wastes, storage and handling should be based on Rules for Management of Radioactive Waste under AERB. Also, if gas cylinders must be stored in the facility, rules applicable for gas cylinders under the Explosives Act shall be followed. Later, these materials must be disposed off at a centralized disposal facility with utmost care following safety norms. Each unit in the facility should have fire hydrant system to handle fire hazards.

4.6.2 Hazard identification

Hazard is the characteristic of any system or process which has the potential for accident. Identification of hazards, in presence of any hazardous waste generating units within the project facility is of primary significance in the analysis, quantification and cost-effective control of accidents involving chemicals and process.

Hence, all components of a system/unit need to be thoroughly examined to assess their potential for initiating or propagating an unplanned event/sequence of events, which can be termed as an accident.

Typical methods for hazard identification employed are:

- Identification of major hazardous units based on Manufacture, Storage and Import of Hazardous Chemicals Rules, 1989 of Government of India (as amended in 2000)
- Identification of hazardous units and segments of plants and storage units based on relative ranking technique, *viz.* Fire-Explosion and Toxicity Index (FE&TI).

Hazardous substances may be classified into three main categories namely flammable, unstable and toxic substances. Flammable substances require interaction with air for their hazard to be realized. Under certain circumstances, vapours arising from flammable substances when mixed with air may become explosive, especially in confined spaces. However, if present in sufficient quantity, such clouds may explode in open air also. Unstable substances are liquids or solids, which may decompose with such violence giving rise to blast waves. Besides, toxic substances are dangerous and cause substantial damage to life when released into the atmosphere. The ratings for a large number of chemicals based on flammability, reactivity and toxicity are provided in NFPA Codes 49 and 345 M.

4.6.3 Hazard assessment and evaluation

A preliminary hazard analysis shall be carried out to identify major hazards associated with storages in the facility. This is followed by consequence analysis to quantify these hazards. Finally the vulnerable zones are plotted for which risk reducing measures are deduced and implemented.

Frequent causes of accidents

- Fire and explosion: explosives, flammable material
- Being struck by falling objects
- Caught in/compressed
- Snapping of cables, ropes, chains, slings
- Handling heavy objects
- Electricity (electrocution)
- Poor illumination
- Falls from height inside industrial units or on the ground
- Struck by moving objects
- Slipping on wet surfaces
- Sharp objects
- Oxygen deficiency in confined spaces
- Lack of personal protective equipment (PPE), housekeeping practices, safety signs
- Hackles, hooks, chains
- Cranes, winches, hoisting and hauling equipment;

Hazardous substances and wastes

- Heavy and toxic metals (lead, mercury, cadmium, copper, zinc, *etc.*)
- Organometallic substances (tributyltin, *etc.*)
- Lack of hazard communication (storage, labelling, material safety data sheets)
- Batteries, fire-fighting liquids
- PCBs and PVC (combustion products)
- Welding fumes
- Volatile organic compounds (solvents)
- Inhalation in confined and enclosed spaces
- Physical hazards
- Noise
- Extreme temperatures
- Vibration
- Radiation (UV, radioactive materials)

Physical hazards

- Noise
- Extreme temperatures
- Vibration
- Radiation (UV, radioactive materials)

Mechanical Hazards

- Trucks and transport vehicles
- Scaffolding, fixed and portable ladders
- Impact by tools, sharp-edged tools
- Power-driven hand tools, saws, grinders and abrasive cutting wheels
- Failure of machinery and equipment
- Poor maintenance of machinery and equipment
- Lack of safety guards in machines
- Structural failure

Biological hazards

- Toxic marine organisms (If the project facility is located in Coastal Regions)
- Risk of communicable diseases transmitted by pests, vermin, rodents, insects and other animals that may infest the project facility.
- Animal bites
- Vectors of infectious diseases (TB, malaria, dengue fever, hepatitis, respiratory infections, others)

Ergonomic and psychosocial hazards

- Repetitive strain injuries, awkward postures, repetitive and monotonous work, excessive workload
- Long working hours, shift work, night work, temporary employment
- Mental stress, human relations (aggressive behaviour, alcohol and drug abuse, violence)
- Poverty, low wages, minimum age, lack of education and social environment

General concerns

- Lack of safety and health training
- Poor work organization
- Inadequate housing and sanitation
- Inadequate accident prevention and inspection
- Inadequate emergency, first-aid and rescue facilities
- Lack of medical facilities and social protection

4.6.4 Disaster management plan

A disaster is a catastrophic situation in which suddenly, people are plunged into helplessness and suffering and, as a result, need protection, clothing, shelter, medical & social care and other necessities of life.

The DMP is aimed to ensure safety of life, protection of environment, protection of installation, restoration of production and salvage operations in this same order of priorities. For effective implementation of DMP, it should be widely circulated and a personnel training is to be provided through rehearsals/drills.

To tackle the consequences of a major emergency inside the plant or immediate vicinity of the plant, a DMP has to be formulated and this planned emergency document is called DMP.

The objective of the DMP is to make use of the combined resources of the plant and the outside services to achieve the following:

- Effective rescue and medical treatment of casualties
- Safeguard other people
- Minimize damage to property and the environment
- Initially contain and ultimately bring the incident under control
- Identify any dead
- Provide for the needs of relatives
- Provide authoritative information to the news media
- Secure the safe rehabilitation of affected area

- Preserve relevant records and equipment for the subsequent inquiry into the cause and circumstances of the emergency

In effect, it is to optimize operational efficiency to rescue rehabilitation and render medical help and to restore normalcy.

The DMP should include emergency preparedness plan, emergency response team, emergency communication, emergency responsibilities, emergency facilities, and emergency actions

4.6.4.1 Emergency preparedness plan

Incidents, accidents and contingency preparedness should be accounted during construction and operation process. This shall be a part of EMS. An environmental emergency plan would essentially provide the following information:

- Assignment of duties and responsibilities among the authorities, participating agencies, response team, their coordinators and/or those responsible for the pollution incident
- Relationship with other emergency plans
- A reporting system that ensures rapid notification in the event of a pollution incident
- The establishment of a focal point for coordination and directions connected to the implementation of the plan
- Response operations should always cover these four phases:
 - Discovery and alarm
 - Evaluation, notification and plan invocation
 - Containment and counter measures
 - Cleanup and disposal
- Identification of expertise and response resources available for assistance for the implementation of plan
- Directions on the necessary emergency provisions applicable to the handling, treatment or disposal of certain pollutants
- Link to the local community for assistance, if necessary
- Support measures, such as procedures for providing public information, carrying out surveillance, issuing post-incident reports, review and updating of the plan, and periodic exercising of the plan.

4.6.4.2 Emergency response

Various units within the project facility are always subjected to accidents and incidents of many a kind. Therefore, a survey of potential incidents and accidents is to be carried out. Based on this, a plan for response to incidents, injuries and emergencies should be prepared. Response to emergencies should ensure that:

- The exposure of workers should be limited as much as possible during the operation
- Contaminated areas should be cleaned and, if necessary disinfected
- Limited impact on the environment at the extent possible.

Written procedures for different types of emergencies should be prepared and the entire workforce should be trained in emergency response. All relevant emergency response equipment should also be readily available.

With regard to dangerous spills, associated cleanup and firefighting operations should be carried out by specially allocated and trained personnel.

4.6.4.3 Response team

It is important to setup an Emergency Organization. A senior executive who has control over the affairs of the plant would be heading the Emergency Organization. He would be designated as Site Controller. Manager (Safety) would be designated as the Incident Controller. In case of stores, utilities, open areas, which are not under control of the Production Heads, Senior Executive responsible for maintenance of utilities would be designated as Incident Controller. All the Incident Controllers would be reporting to the Site Controller.

Each Incident Controller organizes a team responsible for controlling the incidence with the personnel under his control. Shift in charge would be the reporting officer, who would bring the incidence to the notice of the Incidence Controller and Site Controller.

Emergency Coordinators would be appointed who would undertake the responsibilities like firefighting, rescue, rehabilitation, transport and provide essential & support services. For this purposes, Security In charge, Personnel Department, Essential services personnel would be engaged. All these personnel would be designated as key personnel.

In each shift, electrical supervisor, electrical fitters, pump house in charge, and other maintenance staff would be drafted for emergency operations. In the event of power or communication system failure, some of staff members in the office/facility would be drafted and their services would be utilized as messengers for quick passing of communications. All these personnel would be declared as essential personnel.

4.6.4.4 Response to injuries

Based on a survey of possible injuries, a procedure for response to injuries or exposure to hazardous substances should be established. All staff should have minimum training to such response and the procedure ought to include the following:

- Immediate first aid, such as eye splashing, cleansing of wounds and skin, and bandaging
- Immediate reporting to a responsible designated person
- If possible, retention of the item and details of its source for identification of possible hazards
- Rapid additional medical care from medical personnel
- Medical surveillance
- Recording of the incident
- Investigation, determination and implementation of remedial action

It is vital that incident reporting should be straightforward so that reporting is actually carried out.

4.6.4.5 Emergency communication

Whoever notices an emergency situation such as fire, growth of fire, leakage *etc.* would inform his immediate superior and Emergency Control Center. The person on duty in the Emergency Control Center, would appraise the Site Controller. Site Controller verifies the situation from the Incident Controller of that area or the Shift In charge and takes a decision about an impending On-site Emergency. This would be communicated to all the Incident Controllers, Emergency Coordinators. Simultaneously, the emergency warning system would be activated on the instructions of the Site Controller.

4.6.4.6 Emergency responsibilities

The responsibilities of the key personnel should be defined for the following:

- Site controller
- Incident controller
- Emergency coordinator - rescue, fire fighting
- Emergency coordinator-medical, mutual aid, rehabilitation, transport and communication
- Emergency coordinator - essential services
- Employers responsibility

4.6.4.7 Emergency facilities

- Emergency Control Center – with access to important personnel, telephone, fax, telex facility, safe contained breathing apparatus, hand tools, emergency shut down procedures, duties and contact details of key personnel and government agencies, emergency equipments, *etc.*
- Assembly Point – with minimum facilities for safety and rescue
- Emergency Power Supply – connected with diesel generator, flame proof emergency lamps, *etc.*
- Fire Fighting Facilities – first aid fire fighting equipments, fire alarms, *etc.*
- Location of wind Stock – located at appropriate location to indicate the direction of wind for emergency escape
- Emergency Medical Facilities – Stretchers, gas masks, general first aid, emergency control room, breathing apparatus, other emergency medical equipment, ambulance

4.6.4.8 Emergency actions

- Emergency warning
- Evacuation of personnel
- All clear signal
- Public information and warning
- Coordination with local authorities
- Mutual aid
- Mock drills

4.7 Mitigation Measures

The purpose of mitigation is to identify measures that safeguard the environment and the community affected by the proposal. Mitigation is both a creative and practical phase of

the EIA process. It seeks to find the best ways and means of avoiding, minimizing and remedying impacts. Mitigation measures must be translated into action in the correct way and at the right time, if they are to be successful. This process is referred to as impact management and takes place during project implementation. A written plan should be prepared for this purpose, and includes a schedule of agreed actions. Opportunities for impact mitigation will occur throughout the project cycle.

Entire coke oven plant is a hot working place. In well-managed plants, at all hot working spots in a coke oven like end benches, intermediate benches, cellars, coal tower, *etc.*, provision of spot cooling by aerators with water spray is to be provided. The workers can cool themselves at these spots during work gaps to release body heat. All control rooms are to be air-conditioned. The coke quenching car operator's chamber is to be air-conditioned by special air conditioners.

4.7.1 Important considerations for mitigation methods

The responsibility of project proponents to 'internalize' the full environmental costs of development proposals is now widely accepted under "Polluter Pay" principle. In addition, many proponents have found that good design and impact management can result in significant savings applying the principles of cleaner production to improve their environmental performance.

- The predicted adverse environmental as well as social impacts for which mitigation measures are required should be identified and briefly summarized along with cross referencing them to the significance, prediction components of the EIA report or other documentation.
- Each mitigation measure should be briefly described with reference to the impact of significances to which it relates and the conditions under which it is required (for example, continuously or in the event of contingencies). These should also be cross-referenced to the project design and operating procedures which elaborate on the technical aspects of implementing the various measures.
- Cost and responsibilities for mitigation and monitoring should be clearly defined, including arrangements for coordination between the various Authorities responsible for mitigation.
- The proponent can use the EMP to develop environmental performance standards and requirements for the project site as well as supply chain. An EMP can be implemented through EMS for the operational phase of the project.

Prior to selecting mitigation plans it is appropriate to study the mitigation alternatives for cost-effectiveness, technical and socio-political feasibility. Such mitigation measures could include:

- avoiding sensitive areas such as eco-sensitive area *e.g.* fish spawning areas, dense mangrove areas or areas known to contain rare or endangered species
- adjusting work schedules to minimize disturbance
- engineered structures such as berms and noise attenuation barriers
- pollution control devices, such as scrubbers, electrostatic precipitators, bag filters dust suppression systems, BOD plants *etc.*

- changes in fuel feed, manufacturing, process, technology use, or waste management practices, etc.

4.7.2 Hierarchy of elements of mitigation plan

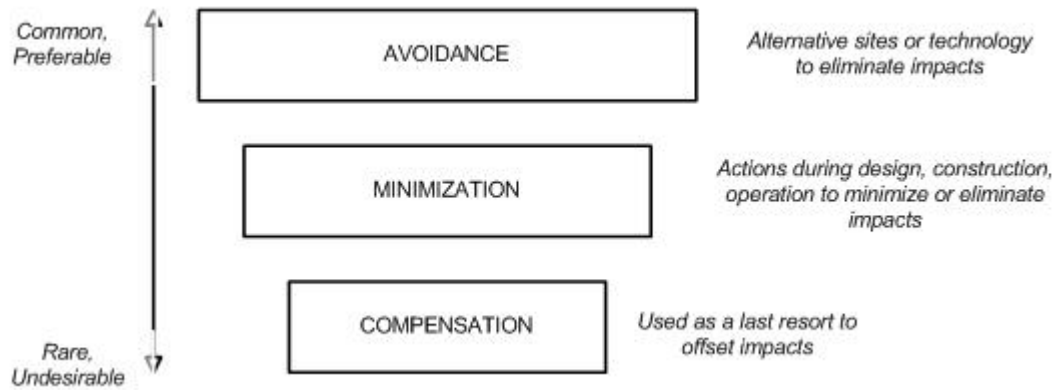

Figure 4-6: Elements of Mitigation

A good EIA practice requires technical understanding of relevant issues and the measures that work in such given circumstances. The priority of selection of mitigation measures should be in the order:

Step One: Impact avoidance

This step is most effective when applied at an early stage of project planning. It can be achieved by:

- not undertaking certain projects or elements that could result in adverse impacts
- avoiding areas that are environmentally sensitive
- putting in place the preventative measures to stop adverse impacts from occurring, for example, release of water from a reservoir to maintain a fisheries regime

Step Two: Impact minimization

This step is usually taken during impact identification and prediction to limit or reduce the degree, extent, magnitude, or duration of adverse impacts. It can be achieved by:

- scaling down or relocating the proposal
- redesigning elements of the project
- taking supplementary measures to manage the impacts

Step Three: Impact compensation

This step is usually applied to remedy unavoidable residual adverse impacts. It can be achieved by:

- rehabilitation of the affected site or environment, for example, by habitat enhancement and restocking fish
- restoration of the affected site or environment to its previous state or better, as typically required for mine sites, forestry roads and seismic lines

- replacement of the same resource values at another location, for example, by wetland engineering to provide an equivalent area to that lost to drainage or infill

Important compensation elements

Resettlement Plans: Special considerations apply to mitigation of proposals that displace or disrupt people. Certain types of projects, such as reservoirs and irrigation schemes and public works, are known to cause involuntary resettlement. This is a contentious issue because it involves far more than re-housing people; in addition, income sources and access to common property resources are likely to be lost. Almost certainly, a resettlement plan will be required to ensure that no one is worse off than before, which may not be possible for indigenous people whose culture and lifestyle is tied to a locality. This plan must include the means for those displaced to reconstruct their economies and communities and should include an EIA of the receiving areas. Particular attention should be given to indigenous, minority and vulnerable groups who are at higher risk from resettlement.

In-kind compensation

When significant or net residual loss or damage to the environment is likely, in kind compensation is appropriate. As noted earlier, environmental rehabilitation, restoration or replacement have become standard practices for many proponents. Now, increasing emphasis is given to a broader range of compensation measures to offset impacts and assure the sustainability of development proposals. These include impact compensation 'trading', such as offsetting CO₂ emissions by planting forests to sequester carbon.

4.7.3 Typical mitigation measures

Choice of location for the developmental activity plays an important role in preventing adverse impacts on surrounding environment. Detailed guidelines on siting of industries are provided in Section 4.2. However, if the developmental activity still produces any adverse impacts, mitigation measures should be taken.

Previous subsections of the Section 4.7 could be precisely summarized into following:

- Impacts from a developmental project could have many dimensions. As most of the direct impacts are caused by releases from developmental projects, often control at source is the best opportunity to either eliminate or mitigate the impacts, in case these are cost-effective. In other words, the best way to mitigate impacts is to prevent them from occurring. Choice of raw materials/technologies/processes which produce least impact would be one of the options to achieve it.
- After exploring cost-effective feasible alternatives to control impacts at source, various interventions to minimize adverse impacts may be considered. These interventions, primarily aim at reducing the residual impacts on the VECs of the receiving environment to the acceptable concentrations.
- Degree of control at source and external interventions differs from situation-to-situation and is largely governed by techno-economic feasibility. While the regulatory bodies stress for further source control (due to high reliability), the project proponents bargain for other interventions which may be relatively cost-effective than further control at source (in any case project authority is required to meet the industry-specific standards by adopting the best practicable technologies. However, if the location demands further control at source, then the proponents are required to adopt further advanced control technologies *i.e.* towards best available control technologies). After

having discussions with the project proponent, EAC/SEAC reaches to an agreed level of source control + other interventions (together called as mitigation measures in the given context) that achieve the targeted protection levels for the VECs in the receiving environment. These levels will become the principal clearance conditions.

- Chapter 3 of this TGM offers elaborate information on cleaner technologies, waste minimization opportunities, and control technologies for various kinds of polluting parameters that emanate from this developmental activity. This information may be used to draw appropriate control measures applicable at source.

The choice of interventions for mitigation of impacts may also be numerous and depend on various factors. Mitigation measures based on location-specific suitability and some other factors are discussed in sub-sections 4.7.1 and 4.7.2. A few typical measures which may also be explored for mitigation of impacts are listed in Table 4-5.

Table 4-5: Typical Mitigation Measures

Impacts	Typical Mitigation Measures
Soil erosion	<ul style="list-style-type: none"> Windscreens, maintenance, and installation of ground cover Installation of drainage ditches Runoff and retention ponds Minimize disturbances and scarification of the surface Usage of appropriate monitoring and control facilities for construction equipments deployed Methods to reuse earth material generated during excavation, <i>etc.</i>
Resources – fuel/construction material, <i>etc.</i>	<ul style="list-style-type: none"> Availing the resources which could be replenished by natural systems, <i>etc.</i>
Deforestation	<ul style="list-style-type: none"> Plant or create similar areas Initiate a tree planning program in other areas Donate land to conservationalist groups, <i>etc.</i>
Water pollution	<ul style="list-style-type: none"> Conjunctive use of ground/surface water, to prevent flooding/water logging/depletion of water resources. Included are land use pattern, land filling, lagoon/reservoir/garland canal construction, and rainwater harvesting and pumping rate. Minimise flow variation from the mean flow Storing of oil wastes in lagoons should be minimised in order to avoid possible contamination of the ground water system. All effluents containing acid/alkali/organic/toxic wastes should be properly treated Monitoring of ground waters Use of biodegradable or otherwise readily treatable additives Neutralization and sedimentation of wastewaters, where applicable Dewatering of sludges and appropriate disposal of solids Construction of liners before disposing waste In case of oil waste, oil separation before treatment and discharge into the environment Controlling discharge of sanitary sewage and industrial waste into the environment Avoiding the activities that increases erosion or that contributes nutrients to water (thus stimulating alga growth) For wastes containing high TDS, treatment methods include removal of liquid and disposal of residue by controlled landfilling to avoid any possible leaching of the fills All surface runoffs around mines or quarries should be collected treated and disposed.

Impacts	Typical Mitigation Measures
	<ul style="list-style-type: none"> ▪ Treated wastewater (such as sewage, industrial wastes, or stored surface runoffs) can be used as cooling water makeup. ▪ Develop spill prevention plans in case of chemical discharges and spills ▪ Develop traps and containment system and chemically treat discharges on site ▪ Channeling and retention of water to reduce erosion and situation ▪ Collection and treatment of sewage and organic waste ▪ Increased recycling and reuse of water ▪ Use of biodegradable or otherwise readily treatable additives ▪ Cooling ponds, towers and canals to reduce temperatures of cooling water discharge ▪ Use deep well injection below potable levels ▪ To avoid to Dilute water at point of discharge ▪ Developing spill prevention plans for metal scrap spills
Air Pollution	<ul style="list-style-type: none"> ▪ Attenuation of pollution/protection of receptor through green belts/green cover ▪ Use of particulate removal devices such as cyclones, setting chambers, scrubbers, electrostatic precipitators, bag houses, <i>etc.</i> ▪ Use of gas removal devices using absorption (liquid as a media), adsorption (molecular sieve), and catalytic converters ▪ Use of protected, controlled equipments such as oxygen masks, <i>etc.</i> ▪ Control of stationary source emission (including evaporation, incineration, absorption, condensation, and material substitution) ▪ Dilution of odourant (dilution can change the nature as well as strength of an odour), odour counteraction or neutralise (certain pairs of odours in appropriate concentrations may neutralise each other), odour masking or blanketing (certain weaker malodours may be suppressed by a considerably stronger good odour). ▪ Regular monitoring of air polluting concentrations
Dust pollution	<ul style="list-style-type: none"> ▪ Wetting of roadways to reduce traffic dust and reentrained particles ▪ Installation of windscreens to breakup the wind flow ▪ Burning of refuse in incinerators on days when meteorological conditions provide for good mixing and dispersion ▪ Proper dust collection and gas cleaning equipment meeting emission limits ▪ Provide dust extraction equipment ▪ Maintain dust levels less than 10 mg/m³ or as stipulated by Factories Act ▪ Monitor for free silica content ▪ Provide dust masks when levels are exceeded
Noise pollution	<ul style="list-style-type: none"> ▪ Heavy duty muffler systems on heavy equipment to reduce noise power level to specification ▪ Limit certain activities ▪ Noise proof enclosures ▪ Plant trees as green belt ▪ Maintain noise levels from below 90 dB(A) ▪ Provide ear protection if in excess ▪ Limit duty hours
Biological	<ul style="list-style-type: none"> ▪ Installation of systems to discourage nesting or perching of birds in dangerous environments ▪ Increased employee awareness to sensitive areas
Social	<ul style="list-style-type: none"> ▪ Health and safety measures for workers ▪ Development of traffic plan that minimizes road use by workers ▪ Upgradation of roads and intersections ▪ Provide sufficient counselling and time to the affected population

Impacts	Typical Mitigation Measures
	for relocation <ul style="list-style-type: none"> ▪ Discuss and finalize alternate arrangements and associated infrastructure in places of religious importance ▪ Exploration of alternative approach routes in consultation with local community and other stakeholders ▪ Provision of alternate jobs in unskilled and skilled categories
Occupational health and safety	<ul style="list-style-type: none"> ▪ Provision of worker camps with proper sanitation and medical facilities, as well as making the worker camps self- sufficient with resources like water supply, power supply, <i>etc</i> ▪ Arrangement of periodic health check-ups for early detection and control of communicable diseases. ▪ Arrangement to dispose off the wastes at approved disposal sites. ▪ Provide preventive measures for potential fire hazards with requisite fire detection, fire-fighting facilities and adequate water storage
Construction	<ul style="list-style-type: none"> ▪ Have a Transport Management Plan in place in order to prevent/minimize the disturbance on surrounding habitats ▪ Initiate traffic density studies
Solid/Hazardous waste	<ul style="list-style-type: none"> ▪ Proper handling of excavated soil ▪ Proper plan to collect and dispose off the solid waste generated onsite. ▪ Identify an authorized waste handler for segregation of construction and hazardous waste and its removal on a regular basis to minimise odour, pest and litter impacts ▪ Prohibit burying of refuse onsite.

4.8 Environmental Management Plan

A typical EMP shall be composed of the following:

1. summary of potential impacts of the proposal
2. description of recommended mitigation measures
3. description of monitoring programme to ensure compliance with relevant standards and residual impacts
4. allocation of resources and responsibilities for plan implementation
5. implementation schedule and reporting procedures
6. contingency plan when impacts are greater than expected

Summary of impacts: The predicted adverse environmental and social impacts for which mitigation measures are identified in the earlier sections to be briefly summarized with cross referencing to the corresponding sections in the EIA report.

Description of mitigation measures: Each mitigation measure should be briefly described w.r.t the impact to which it relates and the conditions under which it is required. These should be accompanied by, or referenced to, project design and operating procedures which elaborate on the technical aspects of implementing the various measures.

Description of monitoring programme to ensure compliance with relevant standards and residual impacts: Environmental monitoring refers to compliance monitoring and residual impact monitoring. Compliance monitoring refers to meeting the industry-specific

statutory compliance requirements (Ref. Applicable National regulations as detailed in Chapter 3).

Residual impact monitoring refers to monitoring of identified sensitive locations with adequate number of samples and frequency. The monitoring programme should clearly indicate the linkages between impacts identified in the EIA report, measurement indicators, detection limits (where appropriate), and definition of thresholds that will signal the need for corrective actions.

Allocation of resources and responsibilities for plan implementation: These should be specified for both the initial investment and recurring expenses for implementing all measures contained in the EMP, integrated into the total project costs, and factored into loan negotiation.

The EMP should contain commitments that are binding on the proponent in different phases of project implementation *i.e.*, pre-construction or site clearance, construction, operation, decommissioning.

Responsibilities for mitigation and monitoring should be clearly defined, including arrangements for co-ordination between the various actors responsible for mitigation. Details should be provided w.r.t the deployment of staff (detailed organogram), monitoring network design, parameters to be monitored, analysis methods, associated equipments, *etc.*

Implementation schedule and reporting procedures: The timing, frequency and duration of mitigation measure should be specified in an implementation schedule, showing links with overall project implementation. Procedures to provide information on the progress and results of mitigation and monitoring measures should also be clearly specified.

Contingency Plan when the impacts are greater than expected: There shall be a contingency plan for attending the situations where the residual impacts are higher than expected. It is an imperative requirement for all project Authorities to plan additional programmes to deal with the situation, after duly intimating the concerned local regulatory bodies.

4.9 Reporting

Structure of the EIA report (Appendix III of the EIA Notification), applicable for Coke oven plant is given in the Table 4.6. Each task prescribed in ToR shall be incorporated appropriately in the contents in addition to the contents described in the table.

Table 4-6: Structure of EIA Report

S.No	EIA Structure	Contents
1.	Introduction	<ul style="list-style-type: none"> ▪ Purpose of the report ▪ Identification of project & project proponent ▪ Brief description of nature, size, location of the project and its importance to the country, region ▪ Scope of the study – details of regulatory scoping carried out (As per Terms of Reference)
2.	Project Description	Condensed description of those aspects of the project (based on project feasibility study), likely to cause environmental effects. Details should be provided to give clear picture of the following:

Operational Aspects of EIA

		<ul style="list-style-type: none"> ▪ Type of project ▪ Need for the project ▪ Location (maps showing general location, specific location, project boundary & project site layout) ▪ Size or magnitude of operation (incl. Associated activities required by or for the project) ▪ Proposed schedule for approval and implementation ▪ Technology and process description ▪ Project description including drawings showing project layout, components of project <i>etc.</i> Schematic representations of the feasibility drawings which give information important for EIA purpose ▪ Description of mitigation measures incorporated into the project to meet environmental standards, environmental operating conditions, or other EIA requirements (as required by the scope) ▪ Assessment of new & untested technology for the risk of technological failure
3.	Description of the Environment	<ul style="list-style-type: none"> ▪ Study area, period, components & methodology ▪ Establishment of baseline for VECs, as identified in the scope ▪ Base maps of all environmental components
4.	Anticipated Environmental Impacts & Mitigation Measures	<ul style="list-style-type: none"> ▪ Details of Investigated Environmental impacts due to project location, possible accidents, project design, project construction, regular operations, final decommissioning or rehabilitation of a completed project ▪ Measures for minimizing and / or offsetting adverse impacts identified ▪ Irreversible and Irretrievable commitments of environmental components ▪ Assessment of significance of impacts (Criteria for determining significance, Assigning significance) ▪ Mitigation measures
5.	Analysis of Alternatives (Technology & Site)	<ul style="list-style-type: none"> ▪ In case, the scoping exercise results in need for alternatives: ▪ Description of each alternative ▪ Summary of adverse impacts of each alternative ▪ Mitigation measures proposed for each alternative and selection of alternative
6.	Environmental Monitoring Program	<ul style="list-style-type: none"> ▪ Technical aspects of monitoring the effectiveness of mitigation measures (incl. measurement methodologies, frequency, location, data analysis, reporting schedules, emergency procedures, detailed budget & procurement schedules)
7.	Additional Studies	<ul style="list-style-type: none"> ▪ Public consultation ▪ Risk assessment ▪ Social impact assessment, R&R action plans
8.	Project Benefits	<ul style="list-style-type: none"> ▪ Improvements in the physical infrastructure ▪ Improvements in the social infrastructure ▪ Employment potential – skilled; semi-skilled and unskilled ▪ Other tangible benefits
9.	Environmental Cost Benefit Analysis	<ul style="list-style-type: none"> ▪ If recommended at the scoping stage
10.	EMP	<ul style="list-style-type: none"> ▪ Description of the administrative aspects that ensures proper implementation of mitigative measures are implemented and their effectiveness monitored, after

		approval of the EIA
11.	Summary & Conclusion (This will constitute the summary of the EIA Report)	<ul style="list-style-type: none"> ▪ Overall justification for implementation of the project ▪ Explanation of how, adverse effects have been mitigated
12.	Disclosure of Consultants engaged	<ul style="list-style-type: none"> ▪ Names of the Consultants engaged with their brief resume and nature of Consultancy rendered

4.10 Public Consultation

Public consultation refers to the process by which the concerns of local affected people and others who have plausible stake in the environmental impacts of the project or activity are ascertained.

- Public consultation is not a decision taking process, but is a process to collect views of the people having plausible stake. If the SPCB/Public agency conducting public hearing is not convinced with the plausible stake, then such expressed views need not be considered.
- Public consultation involves two components, one is public hearing, and other one is inviting written responses/objections through Internet/by post, *etc.*, by placing the summary of EIA report on the web site.
- All Category A and Category B1 projects require public hearing except the following:
 - Once prior environmental clearance is granted to an industrial estates/SEZs/EPZs *etc.*, for a given composition (type and capacity) of industries, then individual units will not require public hearing
 - Expansion of roads and highways, which do not involve any further acquisition of land.
 - Maintenance dredging, provided the dredged material shall be disposed within port limits
 - All building/construction projects/area development projects/townships
 - All Category B2 projects
 - All projects concerning national defense and security or involving other strategic considerations as determined by the Central Government
- Public consultation involves two components, one is public hearing, and other one is inviting written responses/objections through Internet/by post, *etc.*, by placing the summary of EIA report on the website.
- Public hearing shall be carried out at the site or in its close proximity, district-wise, for ascertaining concerns of local affected people.
- Project proponent shall make a request through a simple letter to the Member–Secretary of the SPCB/UTPCC to arrange public hearing.
- Project proponent shall enclose with the letter of request, at least 10 hard copies and 10 soft copies of the draft EIA report including the summary EIA report in English and in official language of the state/local language prepared as per the approved scope of work, to the concerned Authority.
- Simultaneously, project proponent shall arrange to send, one hard copy and one soft copy, of the above draft EIA report along with the summary EIA report to the following Authorities within whose jurisdiction the project will be located:

- District magistrate/District Collector/Deputy Commissioner(s)
- Zilla parishad and municipal corporation or panchayats union
- District industries office
- Urban local bodies (ULBs)/PRIs concerned/development authorities
- Concerned regional office of the MoEF/SPCB
- Above mentioned Authorities except Regional office of MoEF shall arrange to widely publicize the draft EIA report within their respective jurisdictions requesting the interested persons to send their comments to the concerned regulatory Authorities. They shall also make draft EIA report for inspection electronically or otherwise to the public during normal office hours till the public hearing is over.
- Concerned regulatory Authority (MoEF/SEIAA/UTEIA) shall display the summary of EIA report on its website and also make full draft EIA report available for reference at a notified place during normal office hours at their head office.
- SPCB or UTPCC concerned shall also make similar arrangements for giving publicity about the project within the State/UT and make available the summary of draft EIA report for inspection in select offices, public libraries or any other suitable location, *etc.* They shall also additionally make available a copy of the draft EIA report to the above five authorities/offices as mentioned above.
- The Member Secretary of the concerned SPCB or UTPCC shall finalize the date, time and exact venue for the conduct of public hearing within seven days of the date of the receipt of the draft EIA report from the project proponent and advertise the same in one major National Daily and one Regional vernacular Daily/Official State Language.
- A minimum notice period of 30 (thirty) days shall be provided to the public for furnishing their responses.
- No postponement of the date, time, venue of the public hearing shall be undertaken, unless some untoward emergency situation occurs. Only in case of emergencies and up on recommendation of the concerned District Magistrate/District Collector/Deputy Commissioner, the postponement shall be notified to the public through the same National and Regional vernacular dailies and also prominently displayed at all the identified offices by the concerned SPCB/ UTPCC
- In the above exceptional circumstances fresh date, time and venue for the public consultation shall be decided by the Member–Secretary of the concerned SPCB/ UTPCC only in consultation with the District Magistrate and notified afresh as per the procedure.
- The District Magistrate/District collector/Deputy commissioner or his or her representative not below the rank of an Additional District Magistrate assisted by a representative of SPCB or UTPCC, shall supervise and preside over the entire public hearing process.
- The SPCB/UTPCC shall arrange to video film the entire proceedings. A copy of the videotape or a CD shall be enclosed with the public hearing proceedings while forwarding it to the Regulatory Authority concerned.
- The attendance of all those who are present at the venue shall be noted and annexed with the final proceedings
- There shall be *no quorum* required for attendance for starting the proceedings
- Persons present at the venue shall be granted the opportunity to seek information or clarifications on the project from the Applicant. The summary of the public hearing proceedings accurately reflecting all the views and concerns expressed shall be

recorded by the representative of the SPCB/UTPCC and read over to the audience at the end of the proceedings explaining the contents in the local/vernacular language and the agreed minutes shall be signed by the District Magistrate/District Collector/Deputy Commissioner or his or her representative on the same day and forwarded to the SPCB or UTPCC concerned.

- A statement of the issues raised by the public and the comments of the proponent shall also be prepared in the local language or the official State language, as the case may be, and in English and annexed to the proceedings.
- The proceedings of the public hearing shall be conspicuously displayed at the office of the Panchayats within whose jurisdiction the project is located, office of the concerned Zilla Parishad, District Magistrate/District Collector/Deputy Commissioner, , and the SPCB or UTPCC. The SPCB or UTPCC shall also display the proceedings on its website for general information. Comments, if any, on the proceedings, may be sent directly to the concerned regulatory authorities and the proponent concerned.
- The public hearing shall be completed within a period of forty five days from date of receipt of the request letter from the proponent. Therefore the SPCB or UTPCC concerned shall send public hearing proceedings to the concerned regulatory authority within eight (8) days of the completion of the public hearing. Simultaneously, a copy will also be provided to the project proponent. The proponent may also directly forward a copy of the approved public hearing proceedings to the regulatory authority concerned along with the final EIA report or supplementary report to the draft EIA report prepared after the public hearing and public consultations incorporating the concerns expressed in the public hearing along with action plan and financial allocation, item-wise, to address those concerns.
- Upon receipt of the same, the Authority will place executive summary of the report on the website to invite responses from other concerned persons having a plausible stake in the environmental aspects of the project or activity.
- If SPCB/UTPCC is unable to conduct public hearing in the prescribed time, the Central Government incase of Category A projects and State Government or UT administration in case of Category B projects at the request of the SEIAA the project proponent may engage any other agency or authority for conducting the public hearing process within a further period of 45 days. The respective governments shall pay the appropriate fee to the public agency for conducting public hearing.
- A public agency means a non-profit making institution/ body such as technical/academic institutions, government bodies not subordinate to the concerned Authority.
- If SPCB/Public Agency authorized for conducting public hearing informs the Authority, stating that it is not possible to conduct the public hearing in a manner, which will enable the views of the concerned local persons to be freely expressed, then Authority may consider such report to take a decision that in such particular case, public consultation may not have the component of public hearing.
- Often restricting the public hearing to the specific district may not serve the entire purpose, therefore, NGOs who are local and registered under the Societies Act in the adjacent districts may also be allowed to participate in public hearing, if they so desire.
- Confidential information including non-disclosable or legally privileged information involving intellectual property right, source specified in the application shall not be placed on the website.

- The Authority shall make available on a written request from any concerned person the draft EIA report for inspection at a notified place during normal office hours till the date of the public hearing.
- While mandatory requirements will have to be adhered to, utmost attention shall be given to the issues raised in the public hearing for determining the modifications needed in the project proposal and the EMP to address such issues.
- Final EIA report after making needed amendments, as aforesaid, shall be submitted by the proponent to the concerned Authority for prior environmental clearance. Alternatively, a supplementary report to draft EIA and EMP addressing all concerns expressed during the public consultation may be submitted.

4.11 Appraisal

Appraisal means the detailed scrutiny by the EAC/SEAC of the application and the other documents like the final EIA report, outcome of the public consultation including public hearing proceedings submitted by the proponent for grant of prior environmental clearance.

- The appraisal shall be made by EAC to the Central Government or SEAC to SEIAA.
- Project proponent either personally or through consultant can make a presentation to EAC/SEAC for the purpose of appraising the features of the project proposal and also to clarify the issues raised by the members of the EAC/SEAC.
- On completion of these proceedings, concerned EAC/SEAC shall make categorical recommendations to the respective Authority, either for grant of prior environmental clearance on stipulated terms & conditions, if any, or rejection of the application with reasons.
- In case EAC/SEAC needs to visit the site or obtain further information before being able to make categorical recommendations, EAC/SEAC may inform the project proponent accordingly. In such an event, it should be ensured that the process of prior environmental clearance is not unduly delayed to go beyond the prescribed timeframe.
- Upon the scrutiny of the final report, if EAC/SEAC opines that ToR for EIA studies finalized at the scoping stage are covered by the proponent, then the project proponent may be asked to provide such information. If such information is declined by the project proponent or is unlikely to be provided early enough so as to complete the environmental appraisal within prescribed time of 60 days, the EAC/SEAC may recommend for rejection of the proposal with the same reason.
- Appraisal shall be strictly in terms of the ToR for EIA studies finalized at the scoping stage and the concerns expressed during public consultation.
- This process of appraisal shall be completed within 60 days from the receipt of the updated EIA report and EMP report, after completing public consultation.
- The EIA report will be typically examined for following:
 - Project site description supported by topographic maps & photographs – detailed description of topography, land use and activities at the proposed project site and its surroundings (buffer zone) supported by photographic evidence.
 - Clarity in description of drainage pattern, location of eco-sensitive areas, vegetation characteristics, wildlife status - highlighting significant environmental attributes such as feeding, breeding and nesting grounds of wildlife species, migratory corridor, wetland, erosion and neighboring issues.

- Description of the project site – how well the interfaces between the project related activities and the environment have been identified for the entire project cycle *i.e.* construction, operation and decommissioning at the end of the project life.
- If it is envisaged that the project is to be closed after a specified period in case of mining projects, the interface at the closure stage also needs to be described.
- How complete and authentic are the baseline data pertaining to flora and fauna and socio economic aspects?
- Citing of proper references, with regard to the source(s) of baseline data as well as the name of the investigators/ investigating agency responsible for collecting the primary data.
- How consistent are the various values of environmental parameters with respect to each other?
- Is a reasonable assessment of the environmental and social impact made for the identified environmental issues including project affected people?
- To what extent the proposed environmental plan will mitigate the environmental impact and at what estimated cost, shown separately for construction, operation and closure stages and also separately in terms of capital and recurring expenses along with details of agencies that will be responsible for the implementation of environmental plan/ conservation plan.
- How well the concerns expressed/highlighted during the Public hearing have been addressed and incorporated in the EMP giving item wise financial provisions and commitments (in quantified terms)?
- How far the proposed environmental monitoring plan will effectively evaluate the performance of the EMP? Are details for environmental monitoring plan provided in the same manner as the EMP?
- Identification of hazard and quantification of risk assessment and whether appropriate mitigation plan has been included in the EMP?
- Does the proposal include a well formulated time bound green belt development plan for mitigating environmental problems such as fugitive emission of dust, gaseous pollutants, noise, odour, *etc.*
- Does EIA makes a serious attempt to guide the project proponent for minimizing the requirement of natural resources including land, water energy and other non renewable resources?
- How well the EIA statement has been organized and presented so that the issues, their impact and environmental management strategies emerge clearly from it and how well organized was the power point presentation made before the expert committee?
- Is the information presented in the EIA adequately and appropriately supported by maps, imageries and photographs highlighting site features and environmental attributes?

4.12 Decision Making

The Chairperson reads the sense of the Committee and finalizes the draft minutes of the meeting, which are circulated by the Secretary to all expert members invited to the meeting. Based on the response from the members, the minutes are finalized and signed by the

Chairperson. This process for finalization of the minutes should be so organized that the time prescribed for various stages is not exceeded.

Approval / Rejection / Reconsideration

- The Authority shall consider the recommendations of concerned appraisal Committee and convey its decision within 45 days of the receipt of recommendations.
- If the Authority disagrees with the recommendations of the Appraisal Committee, then reasons shall be communicated to concerned Appraisal Committee and proponent within 45 days from the receipt of the recommendations. The Appraisal Committee concerned shall consider the observations of the Authority and furnish its views on the observations within further period of 60 days. The Authority shall take a decision within the next 30 days based on the views of appraisal Committee.
- If the decision of the Authority is not conveyed within the time, then the proponent may proceed as if the prior environmental clearance sought has been granted or denied by the regulatory authority in terms of the final recommendation of the concerned appraisal Committee. For this purpose, the decision of the Appraisal Committee will be a public document, once the period specified above for taking the decision by the Authority is over.
- In case of the Category B projects, application shall be received by the Member Secretary of the SEIAA and clearance shall also be issued by the same SEIAA.
- Deliberate concealment and/or submission of false or misleading information or data which is material to screening or scoping or appraisal or decision on the application shall make the application liable for rejection, and cancellation of prior environmental clearance granted on that basis. Rejection of an application or cancellation of a prior environmental clearance already granted, on such ground, shall be decided by the regulatory authority, after giving a personal hearing to the applicant, and following the principles of natural justice.

If approved

- The concerned MoEF/SEIAA will issue the environmental clearance for the project.
- The project proponent should make sure that the award of prior environmental clearance is properly publicized in at least two local newspapers of the district or state where the proposed project is located. For instance, the executive summary of the prior environmental clearance may be published in the newspaper along with the information about the location (website/office where it is displayed for public) where the detailed prior environmental clearance is made available. The MoEF and SEIAA/UTEIAA, as the case may be, shall also place the prior environmental clearance in the public domain on Government Portal. Further copies of the prior environmental clearance shall be endorsed to the Heads of local bodies, Panchayats and Municipal bodies in addition to the relevant offices of the Government.
- The prior environmental clearance will be valid from the start date to actual commencement of the production of the developmental activity.
- Usual validity period will be 5 years from the date of issuing environmental clearance, unless specified by EAC/SEAC.
- A prior environmental clearance issued to a project proponent can be transferred to another legal person entitled to undertake the project, upon application by the transferor to the concerned Authority or submission of no-objection of the transferor by the

transferee to the concerned Authority for the concurrence. In this case, EAC/SEAC concurrence is not required, but approval from the concerned authority is required to avail the same project configurations, validity period transferred to the new legally entitled person to undertake the project.

4.13 Post-clearance Monitoring Protocol

The MoEF, Government of India will monitor and take appropriate action under the EP Act, 1986.

- In respect of Category A projects, it shall be mandatory for the project proponent to make public the environmental clearance granted for their project along with the environmental conditions and safeguards at their cost by advertising it at least in two local newspapers of the district or State where the project is located and in addition, this shall also be displayed in the project proponents website permanently.
- In respect of Category B projects, irrespective of its clearance by MoEF/SEIAA, the project proponent shall prominently advertise in the newspapers indicating that the project has been accorded environment clearance and the details of MoEF website where it is displayed.
- The MoEF and the SEIAA/UTEIAA, as the case may be, shall also place the environmental clearance in the public domain on Government Portal.
- Copies of environmental clearance shall be submitted by the project proponents to the Heads of the local bodies, Panchayats and Municipal bodies in addition to the relevant offices of the Government who in turn have to display the same for 30 days from the date of receipt.

The project proponent must submit half-yearly compliance reports in respect of the stipulated prior environmental clearance terms and conditions in hard and soft copies to the regulatory authority concerned, on 1st June and 1st December of each calendar year.

All such compliance reports submitted by the project management shall be public documents. Copies of the same shall be given to any person on application to the concerned regulatory authority. Such latest compliance report shall also be displayed on the web site of the concerned regulatory Authority

The SPCB shall incorporate EIA clearance conditions into consent conditions in respect of Category A and Category B projects and in parallel shall monitor and enforce the same.

5.

STAKEHOLDERS' ROLES AND RESPONSIBILITIES

Prior environmental clearance process involves many stakeholders *i.e.*, Central Government, State Government, SEIAA, EAC at the National Level, SEAC, Public Agency, SPCB, the project proponent, and the public.

- Roles and responsibilities of the organizations involved in different stages of prior environmental clearance are listed in Table 5-1.
- Organization-specific functions are listed in Table 5-2.

In this Chapter, constitution, composition, functions, *etc.*, of the Authorities and the Committees are discussed in detail.

Table 5-1: Roles and Responsibilities of Stakeholders Involved in Prior Environmental Clearance

Stage	MoEF/ SEIAA	EAC/ SEAC	Project Proponent	EIA Consultant	SPCB/ Public Agency	Public and Interest Group
Screening	Receives application and takes advice of EAC/ SEAC	Advises the MoEF/ SEIAA	Submits application (Form 1) and provides necessary information	Advises and assists the proponent by providing technical information		
Scoping	Approves the ToR, communicates the same to the project proponent and places the same in the website	Reviews the ToR, visits the proposed site, if required and recommends the ToR to the MoEF/ SEIAA	Submits the draft ToR to SEIAA and facilitates the visit of the EAC/SEAC members to the project site	Prepares ToR		
EIA Report & Public Hearing	Reviews and forwards copies of the EIA report to SPCB /public agency for conducting public hearing Places the		Submits detailed EIA report as per the finalized ToR Facilitates the public hearing by arranging presentation on the project, EIA and EMP – takes note of objections and updates the	Prepares the EIA report Presents and appraises the likely impacts and pollution control measures proposed in the public hearing	Reviews EIA report and conducts public hearing in the manner prescribed Submits proceedings and views of SPCB, to the Authority and the	Participates in public hearings and offers comments and observations. Comments can be sent directly to SEIAA through Internet in

Stakeholders' Roles and Responsibilities

Stage	MoEF/SEIAA	EAC/SEAC	Project Proponent	EIA Consultant	SPCB/Public Agency	Public and Interest Group
	summary of EIA report in the website Conveys objections to the project proponent for update, if any		EMP accordingly		project proponent as well	response to the summary placed in the website
Appraisal and Clearance	Receives updated EIA Takes advice of EAC/SEAC, approves EIA and attaches the terms and conditions	Critically examines the reports, presentation of the proponent and appraises MoEF/SEIAA (recommendations are forwarded to MoEF/SEIAA)	Submits updated EIA, EMP reports to MoEF/SEIAA. Presents the overall EIA and EMP including public concerns to EAC/SEAC	Provides technical advise to the project proponent and if necessary presents the proposed measures for mitigation of likely impacts (terms and conditions of clearance)		
Post-clearance Monitoring			Implements environmental protection measures prescribed and submits periodic monitoring results	Conducts periodic monitoring	Incorporates the clearance conditions into appropriate consent conditions and ensures implementation	

Table 5-2: Organization-specific Functions

Organization	Functions
Central Government	<ul style="list-style-type: none"> ▪ Constitutes the EAC ▪ Considering recommendations of the State Government, constitutes the SEIAA & SEAC ▪ Receives application from the project proponent in case of Category A projects or Category B projects attracting general condition ▪ Communicates the ToR finalized by the EAC to the project proponent. ▪ Receives EIA report from the project proponent and soft copy of summary of the report for placing in the website ▪ Summary of EIA report will be placed in website. Forwards the received responses to

Stakeholders' Roles and Responsibilities

Organization	Functions
	<p>the project proponent</p> <ul style="list-style-type: none"> ▪ Engages other public agency for conducting public hearings in cases where the SPCB does not respond within time ▪ Receives updated EIA report from project proponent incorporating the considerations from the proceedings of public hearing and responses received through other media ▪ Forwards updated EIA report to the EAC for appraisal ▪ Either accepts the recommendations of EAC or asks for reconsideration of specific issues for review by the EAC. ▪ Takes the final decision – acceptance/ rejection – of the project proposal and communicates the same to the project proponent
State Government	<ul style="list-style-type: none"> ▪ Identifies experts as per the composition specified in the Notification and subsequent guidelines to recommend to the the Central Government. ▪ Extends funding support to fulfill the functions of SEIAA/SEAC ▪ Engages other public agency for conducting public hearings in cases where the SPCB does not respond within time ▪ State Governments will suitably pay the public agency for conducting such activity
EAC	<ul style="list-style-type: none"> ▪ Reviews Form 1 and its attachments ▪ Visits site(s), if necessary ▪ Finalizes ToR and recommends to the Central Government, which in turn communicates the finalized ToR to the project proponent, if not exempted by the Notification ▪ Reviews EIA report, proceedings and appraises their views to the Central government ▪ If the Central Government has any specific views, then the EAC reviews again for appraisal
SEIAA	<ul style="list-style-type: none"> ▪ Receives application from the project proponent ▪ Considers SEAC's views for finalization of ToR ▪ Communicates the finalized ToR to the project proponent ▪ Receives EIA report from project proponent ▪ Uploads the summary of EIA report in the website in cases of Category B projects ▪ Forwards the responses received to the project proponent ▪ Receives updated EIA report from project proponent incorporating the considerations from the proceedings of public hearing and responses received through other media ▪ Forwards updated EIA report to SEAC for appraisal ▪ Either accepts the recommendations of SEAC or asks for reconsideration of specific issues for review by SEAC. ▪ Takes the final decision and communicates the same to the project proponent
SEAC	<ul style="list-style-type: none"> ▪ Reviews Form 1 ▪ If necessary visits, site(s) for finalizing the ToR ▪ Reviews updated EIA - EMP report and ▪ Appraises the SEIAA
SPCB	<ul style="list-style-type: none"> ▪ Receives request from project proponent and conducts public hearing in the manner prescribed. ▪ Conveys proceedings to concerned authority and project proponent
Public Agency	<ul style="list-style-type: none"> ▪ Receives request from the respective Governments to conduct public hearing ▪ Conducts public hearing in the manner prescribed. ▪ Conveys proceedings to the concerned Authority/EAC /Project proponent

5.1 SEIAA

- SEIAA is constituted by the MoEF to take final decision regarding the acceptance/rejection of prior environmental clearance to the project proposal for all Category 'B' projects.
- The state government may decide whether to house them at the Department of Environment or at any other Board for effective operational support.

Stakeholders' Roles and Responsibilities

- State Governments can decide whether the positions are permanent or part-time. The Central Government (MoEF) continues to follow the model of paying fee (TA/DA, accommodation, sitting fee) to the Chairperson and the members of EAC. As such, the State Government is to fund SEIAA & SEAC and decide the appropriate institutional support for them.

A. Constitution

- SEIAA is constituted by the Central Government comprising of three members including a Chairperson and Member–Secretary to be nominated by the State Government or UT Administration concerned.
- The Central Government will notify as and when the nominations (in order) are received from the State Governments, within 30 days from the date of receipt.
- The Chairperson and the non-official member shall have a fixed term of three years, from the date of Notification by the Central Government constituting the Authority.

The form used by the State Governments to submit nominations for Notification by the Central Government is provided in **Annexure IX**.

B. Composition

- Chairperson shall be an expert in the EIA process
- Member–Secretary shall be a serving officer of the concerned State Government/ UT Administration familiar with the environmental laws.
- Member–Secretary may be of a level equivalent to the Director, Dept. of Environment or above – a full time member.
- All the members including the Chairperson shall be the experts as per the criteria set in the Notification.
- The Government servants can only serve as the Member–Secretary to SEIAA and the Secretary to SEAC. All other members including Chairperson of the SEIAA and SEAC shall not be comprised of serving Government Officers; industry representatives; and the activists.
- Serving faculty (academicians) is eligible for the membership in the Authority and/or the Committees, if they fulfill the criteria given in Appendix VI to the Notification.
- This is to clarify that the serving Government officers shall not be nominated as professional/expert member of SEIAA/SEAC/EAC.
- Professionals/Experts in the SEIAA and SEAC shall be different.

Summary regarding the eligibility criteria for Chairperson and Members of the SEIAA is given in Table 5-3.

C. Decision-making process

- The decision of the Authority shall be arrived through consensus.
- If there is no consensus, the Authority may either ask SEAC for reconsideration or may reject the approval.
- All decisions of the SEIAA shall be taken in a meeting and shall ordinarily be unanimous, provided that, in case a decision is taken by majority, the details of views,

Stakeholders' Roles and Responsibilities

for and against it, shall be clearly recorded in the minutes and a copy thereof sent to MoEF.

Table 5-3: SEIAA: Eligibility Criteria for Chairperson/ Members/ Secretary

S. No.	Attribute		Requirement		
			Members	Member-Secretary	Chairperson
1	Professional qualification as per the Notification		Compulsory	Compulsory	Compulsory
2	Experience (Fulfilling any one of a, b, c)	a	Professional Qualification + 15 years of experience in one of the expertise area mentioned in the Appendix VI	Professional Qualification + 15 years of experience in one of the expertise area mentioned in the Appendix VI	Professional Qualification + 15 years of experience in one of the expertise area mentioned in the Appendix VI
		b	Professional Qualification +PhD+10 years of experience in one of the expertise area mentioned in Appendix VI	Professional Qualification +PhD+10 years of experience in one of the expertise area mentioned in the Appendix VI	Professional Qualification +PhD+10 years of experience in one of the expertise area mentioned in the Appendix VI
		c	Professional Qualification +10 years of experience in one of the expertise area mentioned in the Appendix VI + 5 years interface with environmental issues, problems and their management	Professional Qualification +10 years of experience in one of the expertise area mentioned in the Appendix VI + 5 years interface with environmental issues, problems and their management	-----
3	Test of independence (conflict of interest) and minimum grade of the Secretary of the Authority		<p>Shall not be a serving government officer</p> <p>Shall not be a person engaged in industry and their associations</p> <p>Shall not be a person associated with environmental activism</p>	<p>Only serving officer from the State Government (DoE) familiar with environmental laws not below the level of Director</p>	<p>Shall not be a serving government officer</p> <p>Shall not be a person engaged in industry and their associations</p> <p>Shall not be a person associated with environmental activism</p>
4	Age		Below 67 years at the time of Notification of the Authority	As per State Government Service Rules	Below 72 Years at the time of the Notification of the Authority
5	Other memberships in Central/State Expert Appraisal Committees		Shall not be a member in any SEIAA/EAC/SEAC	Shall not be a member in any SEIAA/EAC/SEAC	Shall not be a member in any SEIAA/EAC/SEAC
6	Tenure of earlier		Only one term before	Not applicable	Only one term before

Stakeholders' Roles and Responsibilities

S. No.	Attribute	Requirement		
		Members	Member-Secretary	Chairperson
	appointment (continuous)	this in continuity is permitted		this in continuity is permitted
7	Eminent environmental expertise with understanding on environmental aspects and impacts	Desirable	Desirable	Compulsory
8	Expertise in the environmental clearance process	Desirable	Desirable	Compulsory

Note:

1. A member after continuous membership in two terms (6 years) shall not be considered for further continuation. His/her nomination may be considered after a gap of one term (three years), if other criteria meet.
2. Chairperson/Member once notified may not be removed prior to the tenure of three years without cause and proper enquiry.

5.2 EAC and SEAC

EAC and SEAC are independent Committees to review each developmental activity and offer its recommendations for consideration of the Central Government and SEIAA respectively.

A. Constitution

- EAC and SEAC shall be constituted by the Central Government comprising a maximum of 15 members including a Chairperson and Secretary. In case of SEAC, the State Government or UT Administration is required to nominate the professionals/experts for consideration and Notification by the Central Government.
- The Central Government will notify as and when the nominations (in order) are received from the State Governments, within 30 days from the date of receipt.
- The Chairperson and the non-official member shall have a fixed term of three years, from the date of Notification by the Central Government.
- The Chairperson shall be an eminent environmental expert with understanding on environmental aspects and environmental impacts. The Secretary of the SEAC shall be a State Government officer, not below the level of a Director/Chief Engineer.
- The members of the SEAC need not be from the same State/UT.
- In case the State Governments/ Union Territories so desire, the MoEF can form regional EAC to serve the concerned States/Union Territories.
- State Governments may decide to their convenience to house SEAC at the Department of Environment or at SPCB or at any other department, to extend support to the SEAC activities.

B. Composition

- Composition of EAC/SEAC as per the Notification is given in **Annexure X**.
- Secretary to EAC/SEAC may invite a maximum of two professionals/experts with the prior approval of the Chairperson, if desired, for taking the advisory inputs for appraisal. In such case, the invited experts will not take part in the decision making process.
- The Secretary of each EAC/SEAC preferably be an officer of the level equivalent to or above the level of Director, MoEF, GoI.

C. Decision making

The EAC and SEAC shall function on the principle of collective responsibility. The Chairperson shall endeavour to reach a consensus in each case, and if consensus cannot be reached, the view of the majority shall prevail.

D. Operational issues

- Secretary may deal with all correspondence, formulate agenda and prepare agenda notes. Chairperson and other members may act only for the meetings.
- Chairperson of EAC/SEAC shall be one among the expert members having considerable professional experience with proven credentials.
- EAC/SEAC shall meet at least once every month or more frequently, if so needed, to review project proposals and to offer recommendations for the consideration of the Authority.
- EAC/SEAC members may inspect the site at various stages *i.e.* during screening, scoping and appraisal, as per the need felt and decided by the Chairperson of the Committee.
- The respective Governments through the Secretary of the Committee may pay/reimburse the participation expenses, honorarium *etc.*, to the Chairperson and members.

i. Tenure of EAC/SEIAA/SEAC

The tenure of Authority/Committee(s) shall be for a fixed period of three years. At the end of the three years period, the Authority and the committees need to be re-constituted. However, staggered appointment dates may be adopted to maintain continuity of members at a given point of time.

ii. Qualifying criteria for nomination of a member to EAC/SEIAA/SEAC

While recommending nominations and while notifying the members of the Authority and Expert Committees, it shall be ensured that all the members meet the following three criteria:

- Professional qualification
- Relevant experience/Experience interfacing with environmental management
- Absence of conflict of interest

These are elaborated subsequently.

a) Professional qualification

The person should have at least (i) 5 years of formal University training in the concerned discipline leading to a MA/MSc Degree, or (ii) in case of Engineering/Technology/Architecture disciplines, 4 years formal training in a professional training course together with prescribed practical training in the field leading to a B.Tech/B.E./B.Arch. Degree, or (iii) Other professional degree (e.g. Law) involving a total of 5 years of formal University training and prescribed practical training, or (iv) Prescribed apprenticeship/articleship and pass examinations conducted by the concerned professional association (e.g. MBA/IAS/IFS). In selecting the individual professionals, experience gained by them in their respective fields will be taken note of.

b) Relevant experience

- Experience shall be related to professional qualification acquired by the person and be related to one or more of the expertise mentioned for the expert members. Such experience should be a minimum of 15 years.
- When the experience mentioned in the foregoing sub-paragraph interfaces with environmental issues, problems and their management, the requirement for the length of the experience can be reduced to a minimum of 10 years.

c) Absence of conflict of interest

For the deliberations of the EAC/SEAC to be independent and unbiased, all possibilities of potential conflict of interests have to be eliminated. Therefore, serving government officers; persons engaged in industry and their associations; persons associated with the formulation of development projects requiring prior environmental clearance and persons associated with environmental activism shall not be considered for membership of SEIAA/SEAC/ EAC.

iii. Age

Below 70 years for the members and below 72 years for the Chairperson of the SEIAA/SEAC/EAC. The applicability of the age is at the time of the Notification of the SEIAA/SEAC/EAC by the Central Government.

Summary regarding the eligibility criteria for Chairperson and Members of the EAC/SEAC is given in Table 5-4.

Table 5-4: EAC/SEAC: Eligibility Criteria for Chairperson / Members / Secretary

S. No.	Attribute	Requirement		
		Expert members	Secretary	Chairperson
1	Professional qualification as per the Notification	Compulsory	Compulsory	Compulsory

Stakeholders' Roles and Responsibilities

S. No.	Attribute		Requirement		
			Expert members	Secretary	Chairperson
2	Experience (Fulfilling any one of a, b, c)	a	Professional Qualification + 15 years of experience in one of the expertise area mentioned in the Appendix VI	Professional Qualification + 15 years of experience in one of the expertise area mentioned in the Appendix VI	Professional Qualification + 15 years of experience in one of the expertise area mentioned in the Appendix VI
		b	Professional Qualification +PhD+10 years of experience in one of the expertise area mentioned in the Appendix VI	Professional Qualification +PhD+10 years of experience in one of the expertise area mentioned in the Appendix VI	Professional Qualification +PhD+10 years of experience in one of the expertise area mentioned in the Appendix VI
		c	Professional Qualification +10 years of experience in one of the expertise area mentioned in the Appendix VI + 5 years interface with environmental issues, problems and their management	Professional Qualification +10 years of experience in one of the expertise area mentioned in the Appendix VI + 5 years interface with environmental issues, problems and their management	-----
3	Test of independence (conflict of interest) and minimum grade of the Secretary of the Committees	<p>Shall not be a serving government officer</p> <p>Shall not be a person engaged in industry and their associations</p> <p>Shall not be a person associated with environmental activism</p>	<p>In case of EAC, not less than a Director from the MoEF, Government of India</p> <p>In case of SEAC, not below the level of Director/Chief Engineer from the State Government (DoE)</p>	<p>Shall not be a serving government officer</p> <p>Shall not be a person engaged in industry and their associations</p> <p>Shall not be a person associated with environmental activism</p>	
4	Age	Below 67 years at the time of Notification of the Committee	As per state Government Service Rules	Below 72 Years at the time of the Notification of the Committee	
5	Membership in Central/State Expert Appraisal Committee	Only one other than this nomination is permitted	Shall not be a member in other SEIAA/EAC/SEAC	Shall not be a member in any other SEIAA/EAC/SEAC	
6	Tenure of earlier appointment (continuous)	Only one term before this in continuity is permitted	Not applicable	Only one term before this in continuity is permitted	

Stakeholders' Roles and Responsibilities

S. No.	Attribute	Requirement		
		Expert members	Secretary	Chairperson
7	Eminent environmental expertise with understanding on environmental aspects and impacts	Desirable	Not applicable	Compulsory

Notes:

1. A member after continuous membership in two terms (six years) shall not be considered for further continuation. His/her nomination may be reconsidered after a gap of one term (three years), if other criteria meet.

2. Chairperson/Member once notified may not be removed prior to the tenure of 3 years with out cause and proper enquiry. A member after continuous membership in two terms (6 years) shall not be considered for further continuation. The same profile may be considered for nomination after a gap of three years, i.e., one term, if other criteria are meeting.

E. Other conditions which may be considered

- An expert member of one State/UT, can have at the most another State/UT Committee membership, but in no case more than two Committees at a given point of time.
- An expert member of a Committee shall not have membership continuously in the same committee for more than two terms, i.e. six years. They can be nominated after a gap of three years, i.e., one term. When a member of Committee has been associated with any development project, which comes for prior environmental clearance, he/she may not participate in the deliberations and the decisions in respect to that particular project.
- At least four members shall be present in each meeting to fulfill the quorum
- If a member does not consecutively attend six meetings, without prior intimation to the Committee his/her membership may be terminated by the Notifying Authority. Prior information for absence due to academic pursuits, career development and national/state-endorsed programmes may be considered as genuine grounds for retention of membership.

ANNEXURE I
A Compilation of Legal Instruments

Sl. No.	Legal Instrument (Type, Reference, Year)	Responsible Ministries or Bodies	Chemical Use Categories/ Pollutants	Objective of Legislation	Relevant Articles/Provisions
1	Air (Prevention and Control of Pollution) Act, 1981 amended 1987	Central Pollution Control Board and State Pollution Control Boards	Air pollutants from chemical industries	The prevention, control and abatement of air pollution	Section 2: Definitions Section 21: Consent from State Boards Section 22: Not to allow emissions exceeding prescribed limits Section 24: Power of Entry and Inspection Section 25: Power to Obtain Information Section 26: Power to Take Samples Section 37-43: Penalties and Procedures
2	Air (Prevention and Control of Pollution) (Union Territories) Rules, 1983	Central Pollution Control Board and State Pollution Control Boards	Air pollutants from chemical industries	The prevention, control and abatement of air pollution	Rule 2: Definitions Rule 9: Consent Applications
3	Water (Prevention and Control of Pollution) Act, 1974 amended 1988	Central Pollution Control Board and State Pollution Control Boards	Water Pollutants from water polluting industries	The prevention and control of water pollution and also maintaining or restoring the wholesomeness of water	Section 2: Definitions Section 20: Power to Obtain Information Section 21: Power to Take Samples Section 23: Power of Entry and Inspection Section 24: Prohibition on Disposal Section 25: Restriction on New Outlet and New Discharge Section 26: Provision regarding existing discharge of sewage or trade effluent Section 27: Refusal or withdrawal of consent by state boards Section 41-49: Penalties and Procedures
4	Water (Prevention and Control of Pollution) Rules, 1975	Central Pollution Control Board and State Pollution Control Boards	Water Pollutants from water polluting industries	The prevention and control of water pollution and also maintaining or restoring the wholesomeness of water	Rule 2: Definitions Rule 30: Power to take samples Rule 32: Consent Applications

5	The Environment (Protection) Act, 1986, amended 1991	Ministry of Environment and Forests, Central Pollution Control Board and State Pollution Control Boards	All types of environmental pollutants	Protection and Improvement of the Environment	Section 2: Definitions Section 7: Not to allow emission or discharge of environmental pollutants in excess of prescribed standards Section 8: Handling of Hazardous Substances Section 10: Power of Entry and Inspection Section 11: Power to take samples Section 15-19: Penalties and Procedures
6	Environmental (Protection) Rules, 1986 (Amendments in 1999, 2001, 2002, 2002, 2002, 2003, 2004)	Ministry of Environment and Forests, Central Pollution Control Board and State Pollution Control Boards	All types of Environmental Pollutants	Protection and Improvement of the Environment	Rule 2: Definitions Rule 3: Standards for emission or discharge of environmental pollutants Rule 5: Prohibition and restriction on the location of industries and the carrying on process and operations in different areas Rule 13: Prohibition and restriction on the handling of hazardous substances in different areas Rule 14: Submission of environmental statement
7	Hazardous Waste (Management and Handling) Rules, 1989 amended 2000 and 2003	MoEF, CPCB, SPCB, DGFT, Port Authority and Customs Authority	Hazardous Wastes generated from industries using hazardous chemicals	Management & Handling of hazardous wastes in line with the Basel convention	Rule 2: Application Rule 3: Definitions Rule 4: Responsibility of the occupier and operator of a facility for handling of wastes Rule 4A: Duties of the occupier and operator of a facility Rule 4B: Duties of the authority Rule 5: Grant of authorization for handling hazardous wastes Rule 6: Power to suspend or cancel authorization Rule 7: Packaging, labeling and transport of hazardous wastes Rule 8: Disposal sites

					<p>Rule 9: Record and returns</p> <p>Rule 10: Accident reporting and follow up</p> <p>Rule 11: Import and export of hazardous waste for dumping and disposal</p> <p>Rule 12: Import and export of hazardous waste for recycling and reuse</p> <p>Rule 13: Import of hazardous wastes</p> <p>Rule 14: Export of hazardous waste</p> <p>Rule 15: Illegal traffic</p> <p>Rule 16: Liability of the occupier, transporter and operator of a facility</p> <p>Rule 19: Procedure for registration and renewal of registration of recyclers and re-refiners</p> <p>Rule 20: Responsibility of waste generator</p>
8	Manufacture Storage and Import of Hazardous Chemicals Rules, 1989 amended 2000	Ministry of Environment & Forests, Chief Controller of Imports and Exports, CPCB, SPCB, Chief Inspector of Factories, Chief Inspector of Dock Safety, Chief Inspector of Mines, AERB, Chief Controller of Explosives, District Collector or District Emergency Authority, CEES under DRDO	Hazardous Chemicals - Toxic, Explosive, Flammable, Reactive	Regulate the manufacture, storage and import of Hazardous Chemicals	<p>Rule 2: Definitions</p> <p>Rule 4: responsibility of the Occupier</p> <p>Rule 5: Notification of Major Accidents</p> <p>Rule 7-8: Approval and notification of site and updating</p> <p>Rule 10-11: Safety Reports and Safety Audit reports and updating</p> <p>Rule 13: Preparation of Onsite Emergency Plan</p> <p>Rule 14: Preparation of Offsite Emergency Plan</p> <p>Rule 15: Information to persons likely to get affected</p> <p>Rule 16: Proprietary Information</p> <p>Rule 17: Material Safety Data Sheets</p> <p>Rule 18: Import of Hazardous Chemicals</p>
9	Chemical Accidents (Emergency Planning, Preparedness and Response) Rules, 1996	CCG, SCG, DCG, LCG and MAH Units	Hazardous Chemicals - Toxic, Explosive, Flammable, Reactive	Emergency Planning Preparedness and Response to chemical accidents	<p>Rule 2: Definitions</p> <p>Rule 5: Functions of CCG</p> <p>Rule 7: Functions of SCG</p> <p>Rule 9: Functions of DCG</p> <p>Rule 10: Functions of LCG</p>
10	Ozone Depleting Substances	Ministry of Environment &	Ozone depleting substances	Regulate the production, import, use, sale, purchase and	<p>Rule 2: Definitions</p> <p>Rule 3: Regulation of production and</p>

	(Regulation and Control) Rules, 2000	Forests		phase-out of the ODS	consumption of ozone depleting substances Rule 4: Prohibition on export to or import from countries not specified in Schedule VI Rule 5: Ozone depleting substances are to be exported to or imported from countries specified in Schedule VI under a license Rule 6: Regulation of the sale of ozone depleting substances Rule 7: Regulation on the purchase of ozone depleting substances Rule 8: Regulation on the use of ozone depleting substance Rule 9: Prohibition on new investments with ozone depleting substances Rule 10: Regulation of import, export and sale of products made with or containing ozone depleting substances Rule 11: Regulation on reclamation and destruction of ozone depleting substances Rule 12: Regulation on manufacture, import and export of compressors Rule 13: Procedure for registration, cancellation of registration and appeal against such orders Rule 14: Monitoring and reporting requirements
11	EIA Notification, 2006	MoEF, SPCB	For all the identified developmental activities in the notification	Requirement of environmental clearance before establishment of or modernization / expansion of identified developmental projects.	Requirements and procedure for seeking environmental clearance of projects
12	Batteries (Management and Handling) Rules, 2001.	SPCB, CPCB and MoEF	Lead Acid Batteries	To control the hazardous waste generation (lead waste) from used lead acid batteries	Rule 2: Application Rule 3: Definitions Rule 4: Responsibilities of manufacturer, importer, assembler and re-conditioner Rule 5: Registration of Importers Rule 7: Responsibilities of dealer Rule 8: Responsibilities of recycler Rule 9: Procedure for registration / renewal of

					<p>registration of recyclers</p> <p>Rule 10: Responsibilities of consumer or bulk consumer</p> <p>Rule 11: Responsibilities of auctioneer</p> <p>Rule 14: Computerization of Records and Returns</p>
13	Public Liability Insurance Act, 1991 amended 1992	Ministry of Environment & Forests, District Collector	Hazardous Substances	To provide immediate relief to persons affected by accident involving hazardous substances	<p>Section 2: Definitions</p> <p>Section 3: Liability to give relief in certain cases on principle of no fault</p> <p>Section 4: Duty of owner to take out insurance policy</p> <p>Section 7A: Establishment of Environmental Relief Fund</p> <p>Section 14-18: Penalties and Offences</p>
14	Public Liability Insurance Rules, 1991 amended 1993	Ministry of Environment & Forests, District Collector	Hazardous Substances	To provide immediate relief to persons affected by accident involving hazardous substances and also for Establishing an Environmental Relief fund	<p>Rule 2: Definitions</p> <p>Rule 6: Establishment of administration of fund</p> <p>Rule 10: Extent of liability</p> <p>Rule 11: Contribution of the owner to environmental relief fund</p>
15	Factories Act, 1948	Ministry of Labour, DGFASLI and Directorate of Industrial Safety and Health/Factories Inspectorate	Chemicals as specified in the Table	Control of workplace environment, and providing for good health and safety of workers	<p>Section 2: Interpretation</p> <p>Section 6: Approval, licensing and registration of factories</p> <p>Section 7A: General duties of the occupier</p> <p>Section 7B: General duties of manufacturers etc., as regards articles and substances for use in factories</p> <p>Section 12: Disposal of wastes and effluents</p> <p>Section 14: Dust and fume</p> <p>Section 36: Precautions against dangerous fumes, gases, etc.</p> <p>Section 37: Explosion or inflammable dust, gas, etc.</p> <p>Chapter IVA: Provisions relating to Hazardous processes</p> <p>Section 87: Dangerous operations</p> <p>Section 87A: Power to prohibit employment on</p>

					<p>account of serious hazard</p> <p>Section 88: Notice of certain accident</p> <p>Section 88A: Notice of certain dangerous occurrences</p> <p>Chapter X: Penalties and procedures</p>
16	The Explosives Act, 1884	Ministry of Commerce and Industry (Department of Explosives)	Explosive substances as defined under the Act	To regulate the manufacture, possession, use, sale, transport, export and import of explosives with a view to prevent accidents	<p>Section 4: Definition</p> <p>Section 6: Power for Central government to prohibit the manufacture, possession or importation of especially dangerous explosives</p> <p>Section 6B: Grant of Licenses</p>
17	The Explosive Rules, 1983	Ministry of Commerce and Industry and Chief Controller of Explosives, port conservator, customs collector, railway administration	Explosive substances as defined under the Act	To regulate the manufacture, possession, use, sale, transport, export and import of explosives with a view to prevent accidents	<p>Rule 2: Definition</p> <p>Chapter II: General Provisions</p> <p>Chapter III: Import and Export</p> <p>Chapter IV: Transport</p> <p>Chapter V: Manufacture of explosives</p> <p>Chapter VI: Possession sale and use</p> <p>Chapter VII: Licenses</p>
18	The Motor Vehicle Act, 1988	Ministry of Shipping, Road Transport and Highways	Hazardous and Dangerous Goods	To consolidate and amend the law relating to motor vehicles	<p>Section 2: Definition</p> <p>Chapter II: Licensing of drivers of motor vehicle</p> <p>Chapter VII: Construction equipment and maintenance of motor vehicles</p>
19	The Central Motor Vehicle Rules, 1989	Ministry of Shipping, Road Transport and Highways	Hazardous and Dangerous Goods	To consolidate and amend the law relating to motor vehicles including to regulate the transportation of dangerous goods with a view to prevent loss of life or damage to the environment	<p>Rule 2: Definition</p> <p>Rule 9: Educational qualification for driver's of goods carriages carrying dangerous or hazardous goods</p> <p>Rule 129: Transportation of goods of dangerous or hazardous nature to human life</p> <p>Rule 129A: Spark arrestors</p> <p>Rule 130: Manner of display of class labels</p> <p>Rule 131: Responsibility of the consignor for safe transport of dangerous or hazardous goods</p> <p>Rule 132: Responsibility of the transporter or owner of goods carriage</p> <p>Rule 133: Responsibility of the driver</p> <p>Rule 134: Emergency Information Panel</p> <p>Rule 135: Driver to be instructed</p>

					Rule 136: Driver to report to the police station about accident Rule 137: Class labels
20	The Custom Act, 1962	CBEC, Ministry of Finance	Hazardous Goods	To prevent entry of illegal hazardous goods or banned goods including hazardous or banned chemicals	Section 2: definitions Section 11: Power to Prohibit Importation or Exportation of Goods
21	The Merchant Shipping Act, 1958 amended in 2002 and 2003	Ministry of Shipping, Road Transport and Highways	All packaged cargo including Dangerous and hazardous goods as defined in the rules	For safe handling and transportation of cargo including dangerous goods to prevent accident	Section 3: Definitions Section 331: Carriage of Dangerous Goods
22	Merchant Shipping (carriage of Cargo) Rules 1995	Ministry of Shipping, Road Transport and Highways	All packaged cargo including Dangerous and hazardous goods as defined in the rules	For safe handling and transportation of cargo including dangerous goods to prevent accident	
23	The Indian Port Act, 1908	Ministry of Shipping, Road Transport and Highways	All Chemicals - handling and storage	For control of activities on ports including safety of shipping and conservation of ports	Section 2: Definitions Chapter IV: Rules for the safety of shipping and the conservation of ports Chapter VII: Provisions with respect to penalties
24	The Dock Workers, (Safety, Health and Welfare) Act, 1986	Ministry of Labour, DGFASLI and Directorate of Dock Safety	All Chemicals termed as dangerous goods	Safety of Dock workers including handling of dangerous goods	
25	The Dock Workers, (Safety, Health and Welfare) Rules, 1990	Ministry of Labour, DGFASLI and Directorate of Dock Safety	All Chemicals termed as dangerous goods	Safety of Dock workers including handling of dangerous goods	

ANNEXURE II
General Standards for Discharge of Environmental Pollutants as per
CPCB

Table: Water Quality Standards

S. No.	Parameter	Standards			
		Inland Surface Water	Public Sewer	Land for Irrigation	Marine Coastal Areas
1.	2.	3.			
		(a)	(b)	(c)	(d)
1.	Colour and odour	See Note-1	—	See Note-1	See Note-1
2.	Suspended Solids, mg/l, Max	100	600	200	(a) For process waste water-100 (b) For cooling water effluent-10 per cent above total suspended matter of influent cooling water.
3.	Particle size of suspended solids	Shall pass 850 micron IS Sieve	—	—	(a) Floatable solids, Max 3 mm (b) Settleable solids Max 850 microns.
4.	Dissolved solids (inorganic), mg/a, mac	2100	2100	2100	—
5.	pH value	5.5 to 9.0	5.5 to 9.0	5.5 to 9.0	5.5 to 9.0
6.	Temperature °C, Max	Shall not exceed 40 in any section of the stream within 15 meters down stream from the effluent outlet	45 at the point of discharge	—	45 at the point of discharge
7.	Oil and grease, mg/l, max	10	20	10	20
8.	Total residual chlorine, mg/l, Max.	1.0	—	—	1.0
9.	Ammonical nitrogen (as N), mg/l, Max.	50	50	—	50
10.	Total Kjeldahl nitrogen (as N), mg/l, Max.	100	—	—	100
11.	Free Ammonia (as NH ₃), mg/l, Max.	5.0	—	—	5.0
12.	Biochemical Oxygen Demand (5 days at 20°C) Max.	30	350	100	100
13.	Chemical Oxygen Demand, mg/l, Max.	250	—	—	250
14.	Arsenic (as As), mg/l, Max.	0.2	0.2	0.2	0.2
15.	Mercury (as Hg), mg/l, Max.	0.01	0.01	—	0.01
16.	Lead (as Pb), mg/l, Max.	0.1	1.0	—	1.0
17.	Cadmium (as Cd), mg/l, Max.	2.0	1.0	—	2.0

18.	Hexavalent chromium (as Cr+6) mg/l, Max.	0.1	2.0	—	1.0
19.	Total chromium as (Cr), mg/l, Max.	2.0	2.0	—	2.0
20.	Copper (as Cu), mg/l, Max.	3.0	3.0	—	3.0
21.	Zinc (as Zn), mg/l, Max.	5.0	15	—	15
22.	Selenium (as Se), mg/l, Max.	0.05	0.05	—	0.05
23.	Nickel (as Ni), mg/l, Max.	3.0	3.0	—	5.0
24.	Boron (as B), mg/l, Max.	2.0	2.0	2.0	—
25.	Percent Sodium, Max.	—	60	60	—
26.	Residual sodium carbonate, mg/l, Max.	—	—	5.0	—
27.	Cyanide (as CN), mg/l, Max.	0.2	2.0	0.2	0.2
28.	Chloride (as Cl), mg/l, Max.	1000	1000	600	(a)
29.	Fluoride (as F), mg/l, Max.	2.0	15	—	15
30.	Dissolved Phosphates (as P), mg/l, Max.	5.0	—	—	—
31.	Sulphate (as SO ₄), mg/l, Max.	1000	1000	1000	—
32.	Sulphide (as S), mg/l, Max.	2.0	—	—	5.0
33.	Pesticides	Absent	Absent	Absent	Absent
34.	Phenolic compounds (as C ₆ H ₅ OH), mg/l, Max.	1.0	5.0	—	5.0
35.	Radioactive materials				
	(a) Alpha emitters MC/ml, Max.	10 ⁻⁷	10 ⁻⁷	10 ⁻⁸	10 ⁻⁷
	(b) Beta emitters uc/ml, Max.	10 ⁻⁶	10 ⁻⁶	10 ⁻⁷	10 ⁻⁶

Note :-

1. All efforts should be made to remove colour and unpleasant odour as far as practicable.
2. The standards mentioned in this notification shall apply to all the effluents discharged such as industrial mining and mineral processing activities municipal sewage etc.

Table: Noise Standards

Ambient air quality standards in respect of noise

Area Code	Category of Area	Limits in dB (A) Leq	
		Day Time	Night Time
(A)	Industrial area	75	70
(B)	Commercial area	65	55
(C)	Residential area	55	45
(D)	Silence zone	50	40

Note :

1. Day time is reckoned in between 6.00 AM and 9.00 PM
2. Night time is reckoned in between 9.00 PM and 6.00 AM
3. Silence zone is defined as areas upto 100 meters around such premises as hospitals, educational institutions and courts. The Silence zones are to be declared by the Competent Authority.
4. Use of vehicular horns, loudspeakers and bursting of crackers shall be banned in these zones.
5. Mixed categories of areas should be declared as one of the four above mentioned categories by the Competent Authority and the corresponding standards shall apply.

Standards/Guidelines for Control of Noise Pollution from Stationary Diesel Generator (DG) Sets

(A) Noise Standards for DG Sets (15-500 KVA)

The total sound power level, L_w , of a DG set should be less than, $94+10 \log_{10} (KVA)$, dB (A), at the manufacturing stage, where, KVA is the nominal power rating of a DG set.

This level should fall by 5 dB (A) every five years, till 2007, i.e. in 2002 and then in 2007.

(B) Mandatory acoustic enclosure/acoustic treatment of room for stationary DG sets (5 KVA and above)

Noise from the DG set should be controlled by providing an acoustic enclosure or by treating the room acoustically.

The acoustic enclosure/acoustic treatment of the room should be designed for minimum 25 dB(A) Insertion Loss or for meeting the ambient noise standards, whichever is on the higher side (if the actual ambient noise is on the higher side, it may not be possible to check the performance of the acoustic enclosure/acoustic treatment. Under such circumstances the performance may be checked for noise reduction upto actual ambient noise level, preferably, in the night time). The measurement for Insertion Loss may be done at different points at 0.5m from the acoustic enclosure/room, and then averaged.

The DG set should also be provide with proper exhaust muffler with Insertion Loss of minimum 25 dB(A).

(C) Guidelines for the manufacturers/users of DG sets (5 KVA and above)

1. The manufacturer should offer to the user a standard acoustic enclosure of 25 dB(A) Insertion Loss and also a suitable exhaust muffler with Insertion Loss of 25 dB(A).

2. The user should make efforts to bring down the noise levels due to the DG set, outside his premises, within the ambient noise requirements by proper siting and control measures.
3. The manufacturer should furnish noise power levels of the unlicensed DG sets as per standards prescribed under (A)
4. The total sound power level of a DG set, at the user's end, shall be within 2 dB(A) of the total sound power level of the DG set, at the manufacturing stage, as prescribed under (A).
5. Installation of a DG set must be strictly in compliance with the recommendation of the DG set manufacturer.
6. A proper routine and preventive maintenance procedure for the DG set should be set and followed in consultation with the DG set manufacturer which would help prevent noise levels of the DG set from deteriorating with use.

Order of the Lt. Governor of Delhi in respect of D.G. Sets (5th December, 2001)

In exercise of the powers conferred by section 5 of the Environment (Protection) Act, 1986, (29 of 1986), read with the Government of India, Ministry of Home Affairs notification S.O. 667 (E) bearing No. F.No. U-11030/J/91-VTL dated 10th September, 1992, the Lt. Governor of Government of National Capital of Delhi hereby directs to all owners/users of generators sets in the National Capital Territory of Delhi as follows :-

1. that generator sets above the capacity of 5 KVA shall not be operated in residential areas between the hours of 10.00 PM to 6.00 AM;
2. that the generator sets above the capacity of 5 KVA in all areas residential/commercial/industrial shall operate only with the mandatory acoustic enclosures and other standards prescribed in the Environment (Protection) Rules, 1986;
3. that mobile generator sets used in social gatherings and public functions shall be permitted only if they have installed mandatory acoustic enclosures and adhere to the prescribed standards for noise and emission as laid down in the Environment (Protection) Rules, 1986.

The contravention of the above directions shall make the offender liable for prosecution under section 15 of the said Act which stipulates punishment of imprisonment for a term which may extend to five years with fine which may extend to one lakh rupees, or with both, and in case the failure of contravention continues, with additional fine which may extend to five thousand rupees for every day during which such failure or contravention continues after the conviction for the first such failure or contravention and if still the failure or contravention continues beyond a period of one year after the date of contravention, the offender continues beyond a period of one year after the date of contravention, the offender shall be punishable with imprisonment for a term which may extend to seven years.

Order Dated: 21st June, 2002

In exercise of the powers conferred by section 5 of the Environment (Protection) Act, 1986 (29 of 1986) read with the Govt. of India, Ministry of Home Affairs notification S.O. 667(E) bearing No. U-11030/J/91-VTL dated the 10th September, 1992, the Lt. Governor Govt. of the National Capital Territory of Delhi hereby makes the following amendment/modification in his order dated the 5th December, 2001 regarding the operation of generator sets, namely:-

Amendments/modifications

In the above said order, for clause(1), the following shall be substituted, namely:-

“(1) that the generator sets above 5KVA shall not be operated in residential areas between the hours from 10.00 p.m. to 6.00 a.m. except generator sets of Group Housing Societies and Multi-storey residential apartments”.

DIESEL GENERATOR SETS: STACK HEIGHT

The minimum height of stack to be provided with each generator set can be worked out using the following formula:

$$H = h + 0.2 \times \sqrt{KVA}$$

H = Total height of stack in metre

h = Height of the building in metres where the generator set is installed

KVA = Total generator capacity of the set in KVA

Based on the above formula the minimum stack height to be provided with different range of generator sets may be categorized as follows:

For Generator Sets	Total Height of stack in metre
50 KVA	Ht. of the building + 1.5 metre
50-100 KVA	Ht. of the building + 2.0 metre
100- 150 KVA	Ht. of the building + 2.5 metre
150-200 KVA	Ht. of the building + 3.0 metre
200-250 KVA	Ht. of the building + 3.5 metre
250-300 KVA	Ht. of the building + 3.5 metre

Similarly for higher KVA ratings a stack height can be worked out using the above formula

Source: Evolved By CPCB

[Emission Regulations Part IV: COINDS/26/1986-87]

ANNEXURE III
Form 1 (Application for Obtaining EIA Clearance)

FORM 1

(I) Basic Information

S. No.	Item	Details
1.	Name of the project/s	
2.	S.No. in the schedule	
3.	Proposed capacity/area/length/tonnage to be handled/command area/lease area/number of wells to be drilled	
4.	New/Expansion/Modernization	
5.	Existing Capacity/Area etc.	
6.	Category of Project i.e., 'A' or 'B'	
7.	Does it attract the general condition? If yes, please specify.	
8.	Does it attract the specific condition? If yes, Please specify.	
9.	Location	
	Plot/Survey/Khasra No.	
	Village	
	Tehsil	
	District	
	State	
10.	Nearest railway station/airport along with distance in kms.	
11.	Nearest Town, city, District headquarters along with distance in kms.	
12.	Village Panchayats, Zilla Parishad, Municipal Corporation, Local body (complete postal addresses with telephone nos. to be given)	
13.	Name of the applicant	
14.	Registered Address	
15.	Address for correspondence:	
	Name	
	Designation (Owner/Partner/CEO)	
	Address	
	Pin Code	
	E-mail	
	Telephone No.	

S. No.	Item	Details
	Fax No.	
16.	Details of alternative Sites examined, if any location of these sites should be shown on a toposheet.	Village-District-State 1. 2. 3.
17.	Interlined Projects	
18.	Whether separate application of interlined project has been submitted	
19.	If yes, date of submission	
20.	If no, reason	
21.	Whether the proposal involves approval/clearance under: if yes, details of the same and their status to be given. (a) The Forest (Conservation) Act, 1980 ? (b) The Wildlife (Protection) Act, 1972 ? (c) The C.R.Z. Notification, 1991 ?	
22.	Whether there is any Government Order/Policy relevant/relating to the site?	
23.	Forest land involved (hectares)	
24.	Whether there is any litigation pending against the project and/or land in which the project is propose to be set up (a) Name of the Court (b) Case No. (c) Orders/directions of the Court, if any and its relevance with the proposed project.	

(II) Activity

1. **Construction, operation or decommissioning of the Project involving actions, which will cause physical changes in the locality (topography, land use, changes in water bodies, etc.)**

S.No.	Information/Checklist confirmation	Yes/No	Details thereof (with approximate quantities /rates, wherever possible) with source of information data
1.1	Permanent or temporary change in land use, land cover or topography including increase in intensity of land use (with respect to local land use plan)		
1.2	Clearance of existing land, vegetation and		

S.No.	Information/Checklist confirmation	Yes/No	Details thereof (with approximate quantities /rates, wherever possible) with source of information data
	buildings?		
1.3	Creation of new land uses?		
1.4	Pre-construction investigations e.g. bore houses, soil testing?		
1.5	Construction works?		
1.6	Demolition works?		
1.7	Temporary sites used for construction works or housing of construction workers?		
1.8	Above ground buildings, structures or earthworks including linear structures, cut and fill or excavations		
1.9	Underground works including mining or tunneling?		
1.10	Reclamation works?		
1.11	Dredging?		
1.12	Offshore structures?		
1.13	Production and manufacturing processes?		
1.14	Facilities for storage of goods or materials?		
1.15	Facilities for treatment or disposal of solid waste or liquid effluents?		
1.16	Facilities for long term housing of operational workers?		
1.17	New road, rail or sea traffic during construction or operation?		
1.18	New road, rail, air waterborne or other transport infrastructure including new or altered routes and stations, ports, airports etc?		
1.19	Closure or diversion of existing transport routes or infrastructure leading to changes in traffic movements?		
1.20	New or diverted transmission lines or pipelines?		
1.21	Impoundment, damming, culverting, realignment or other changes to the hydrology of watercourses or aquifers?		
1.22	Stream crossings?		
1.23	Abstraction or transfers of water form ground or surface waters?		

S.No.	Information/Checklist confirmation	Yes/No	Details thereof (with approximate quantities /rates, wherever possible) with source of information data
1.24	Changes in water bodies or the land surface affecting drainage or run-off?		
1.25	Transport of personnel or materials for construction, operation or decommissioning?		
1.26	Long-term dismantling or decommissioning or restoration works?		
1.27	Ongoing activity during decommissioning which could have an impact on the environment?		
1.28	Influx of people to an area in either temporarily or permanently?		
1.29	Introduction of alien species?		
1.30	Loss of native species or genetic diversity?		
1.31	Any other actions?		

2. Use of Natural resources for construction or operation of the Project (such as land, water, materials or energy, especially any resources which are non-renewable or in short supply):

S.No.	Information/checklist confirmation	Yes/No	Details thereof (with approximate quantities /rates, wherever possible) with source of information data
2.1	Land especially undeveloped or agricultural land (ha)		
2.2	Water (expected source & competing users) unit: KLD		
2.3	Minerals (MT)		
2.4	Construction material – stone, aggregates, sand / soil (expected source – MT)		
2.5	Forests and timber (source – MT)		
2.6	Energy including electricity and fuels (source, competing users) Unit: fuel (MT), energy (MW)		
2.7	Any other natural resources (use appropriate standard units)		

3. Use, storage, transport, handling or production of substances or materials, which could be harmful to human health or the environment or raise concerns about actual or perceived risks to human health.

S.No	Information/Checklist confirmation	Yes/No	Details thereof (with approximate quantities/rates, wherever possible) with source of information data
3.1	Use of substances or materials, which are hazardous (as per MSIHC rules) to human health or the environment (flora, fauna, and water supplies)		
3.2	Changes in occurrence of disease or affect disease vectors (e.g. insect or water borne diseases)		
3.3	Affect the welfare of people e.g. by changing living conditions?		
3.4	Vulnerable groups of people who could be affected by the project e.g. hospital patients, children, the elderly etc.,		
3.5	Any other causes		

4. Production of solid wastes during construction or operation or decommissioning (MT/month)

S.No.	Information/Checklist confirmation	Yes/No	Details thereof (with approximate quantities/rates, wherever possible) with source of information data
4.1	Spoil, overburden or mine wastes		
4.2	Municipal waste (domestic and or commercial wastes)		
4.3	Hazardous wastes (as per Hazardous Waste Management Rules)		
4.4	Other industrial process wastes		
4.5	Surplus product		
4.6	Sewage sludge or other sludge from effluent treatment		
4.7	Construction or demolition wastes		
4.8	Redundant machinery or equipment		
4.9	Contaminated soils or other materials		
4.10	Agricultural wastes		
4.11	Other solid wastes		

5. Release of pollutants or any hazardous, toxic or noxious substances to air (kg/hr)

S.No	Information/Checklist confirmation	Yes/No	Details thereof (with approximate quantities/rates, wherever possible) with source of information data
5.1	Emissions from combustion of fossil fuels from stationary or mobile sources		
5.2	Emissions from production processes		
5.3	Emissions from materials handling including storage or transport		
5.4	Emissions from construction activities including plant and equipment		
5.5	Dust or odours from handling of materials including construction materials, sewage and waste		
5.6	Emissions from incineration of waste		
5.7	Emissions from burning of waste in open air (e.g. slash materials, construction debris)		
5.8	Emissions from any other sources		

6. Generation of Noise and Vibration, and Emissions of Light and Heat:

S.No.	Information/Checklist confirmation	Yes/No	Details thereof (with approximate quantities/rates, wherever possible) with source of information data with source of information data
6.1	From operation of equipment e.g. engines, ventilation plant, crushers		
6.2	From industrial or similar processes		
6.3	From construction or demolition		
6.4	From blasting or piling		
6.5	From construction or operational traffic		
6.6	From lighting or cooling systems		
6.7	From any other sources		

7. Risks of contamination of land or water from releases of pollutants into the ground or into sewers, surface waters, groundwater, coastal waters or the sea:

S.No.	Information/Checklist confirmation	Yes/No	Details thereof (with approximate quantities/rates, wherever possible) with source of information data
7.1	From handling, storage, use or spillage of hazardous materials		
7.2	From discharge of sewage or other effluents to water or the land (expected mode and place of discharge)		
7.3	By deposition of pollutants emitted to air into the land or into water		
7.4	From any other sources		
7.5	Is there a risk of long term build up of pollutants in the environment from these sources?		

8. Risk of accidents during construction or operation of the Project, which could affect human health or the environment

S.No	Information/Checklist confirmation	Yes/No	Details thereof (with approximate quantities/rates, wherever possible) with source of information data
8.1	From explosions, spillages, fires etc from storage, handling, use or production of hazardous substances		
8.2	From any other causes		
8.3	Could the project be affected by natural disasters causing environmental damage (e.g. floods, earthquakes, landslides, cloudburst etc)?		

9. Factors which should be considered (such as consequential development) which could lead to environmental effects or the potential for cumulative impacts with other existing or planned activities in the locality

S. No.	Information/Checklist confirmation	Yes/No	Details thereof (with approximate quantities/rates, wherever possible) with source of information data
---------------	---	---------------	---

9.1	Lead to development of supporting facilities, ancillary development or development stimulated by the project which could have impact on the environment e.g.: <ul style="list-style-type: none"> ▪ Supporting infrastructure (roads, power supply, waste or waste water treatment, etc.) ▪ housing development ▪ extractive industries ▪ supply industries ▪ other 		
9.2	Lead to after-use of the site, which could have an impact on the environment		
9.3	Set a precedent for later developments		
9.4	Have cumulative effects due to proximity to other existing or planned projects with similar effects		

(III) Environmental Sensitivity

S.No.	Areas	Name/ Identity	Aerial distance (within 15 km.) Proposed project location boundary
1	Areas protected under international conventions, national or local legislation for their ecological, landscape, cultural or other related value		
2	Areas which are important or sensitive for ecological reasons - Wetlands, watercourses or other water bodies, coastal zone, biospheres, mountains, forests		
3	Areas used by protected, important or sensitive species of flora or fauna for breeding, nesting, foraging, resting, over wintering, migration		
4	Inland, coastal, marine or underground waters		
5	State, National boundaries		
6	Routes or facilities used by the public for access to recreation or other tourist, pilgrim areas		
7	Defence installations		
8	Densely populated or built-up area		
9	Areas occupied by sensitive man-made land uses (<i>hospitals, schools, places of worship,</i>		

	<i>community facilities)</i>		
10	Areas containing important, high quality or scarce resources (<i>ground water resources, surface resources, forestry, agriculture, fisheries, tourism, minerals</i>)		
11	Areas already subjected to pollution or environmental damage. (<i>those where existing legal environmental standards are exceeded</i>)		
12	Areas susceptible to natural hazard which could cause the project to present environmental problems (<i>earthquakes, subsidence, landslides, erosion, flooding or extreme or adverse climatic conditions</i>)		

(IV) PROPOSED TERMS OF REFERENCE FOR EIA STUDIES

“I hereby given undertaking that the data and information given in the application and enclosures are true to the best of my knowledge and belief and I am aware that if any part of the data and information submitted is found to be false or misleading at any stage, the project will be rejected and clearance give, if any to the project will be revoked at our risk and cost.

Date: _____

Place: _____

Signature of the applicant
With Name and Full Address
(Project Proponent / Authorized Signatory)

NOTE:

1. The projects involving clearance under Coastal Regulation Zone Notification, 1991 shall submit with the application a C.R.Z. map duly demarcated by one of the authorized agencies, showing the project activities, w.r.t. C.R.Z. (at the stage of TOR) and the recommendations of the State Coastal Zone Management Authority (at the stage of EC). Simultaneous action shall also be taken to obtain the requisite clearance under the provisions of the C.R.Z. Notification, 1991 for the activities to be located in the CRZ.
2. The projects to be located within 10 km of the National Parks, Sanctuaries, Biosphere Reserves, Migratory Corridors of Wild Animals, the project proponent shall submit the map duly authenticated by Chief Wildlife Warden showing these features vis-à-vis the project location and the recommendations or comments of the Chief Wildlife Warden thereon (at the stage of EC).”
3. All corrspondence with the Ministry of Environment & Forests including submission of application for TOR/Environmental Clearance, subsequent clarifications, as may be requiered from time to time, participation in the EAC Meeting on behalf of the project proponent shall be made by the authorized signatory only. The authorized signatory should also submit a document in support of his claim of being an authorized signatory for the specific project.”

ANNEXURE IV
Critically Polluted Industrial Areas and Clusters/Potential Impact
Zones

**Table 1: Details of Critically Polluted Industrial Areas and Clusters / Potential Impact Zone
(Ref: Office Memorandum No. J-11013/5/2010-IA.II(I) Dated 13.1.2010)**

S. No.	Critically Polluted Industrial Area and CEPI	Industrial Clusters/ Potential Impact Zones
1.	Ankeshwar (Gujarat) CEPI-88.50(Ac_Wc_Lc)	<ul style="list-style-type: none"> ▪ GIDC Ankeshwar and GIDC, Panoli
2	Vapi (Gujarat) CEPI-88.09(Ac_Wc_Lc)	<ul style="list-style-type: none"> ▪ GIDC Vapi
3	Ghaziabad (Uttar Pradesh) CEPI-87.37(Ac_Wc_Lc)	<p>Sub-cluster A</p> <ul style="list-style-type: none"> ▪ Mohan nagar industrial area ▪ Rajinder nagar industrial area ▪ Sahibabad industrial area <p>Sub-cluster B</p> <ul style="list-style-type: none"> ▪ Pandav nagar industrial area ▪ Kavi nagar industrial area ▪ Bulandshahar road industrial area ▪ Amrit nagar ▪ Aryanagar industrial area <p>Sub-cluster C</p> <ul style="list-style-type: none"> ▪ Merrut road industrial are <p>Sub-cluster D</p> <ul style="list-style-type: none"> ▪ Loni industrial area ▪ Loni Road industrial area ▪ Roop nagar industrial area <p>Sub-cluster E</p> <ul style="list-style-type: none"> ▪ Hapur Road industrial area ▪ Dasna ▪ Philkura <p>Sub-cluster F (Other scattered industrial areas)</p> <ul style="list-style-type: none"> ▪ South side of GT road ▪ Kavi Nagar ▪ Tronica city ▪ Anand Nagar ▪ Jindal Nagar ▪ Prakash Nagar ▪ Rural industrial estate
4	Chandrapur (Maharashtra) CEPI-83.88 (Ac_Wc_Lc)	<ul style="list-style-type: none"> ▪ Chandrapur (MIDC Chandrapur, Tadali, Ghuggus, Ballapur)
5	Kobra (Chhatisgarh) CEPI-83.00 (Ac_Ws_Lc)	<ul style="list-style-type: none"> ▪ Industrial areas and their townships of NTPC, BALCO, CSEB (East) & CSEB (West) ▪ Korba town
6	Bhiwadi (Rajasthan) CEPI-82.91 (Ac_Wc_Ls)	<ul style="list-style-type: none"> ▪ RIICO industrial areas Phase I to IV ▪ Bhiwadi town ▪ Other surrounding industrial areas: Chopanki, Rampura Mundana, Khuskhera Phase I to III
7	Angul Talcer(Orissa) CEPI-82.09 (Ac_Wc_Lc)	<ul style="list-style-type: none"> ▪ MCL Coal mining area, Augul – Talcer region ▪ Industrial area (60 km x 45 km) <p>Following blocks of Augul district:</p> <ul style="list-style-type: none"> ▪ Kohina block ▪ Talcher block

		<ul style="list-style-type: none"> ▪ Angul block ▪ Chhendipada block ▪ Banarpal block ▪ Odapada block of Dhenkamal district
8	Vellore (North Arcot) (Tamil Nadu) CEPI-81.79 (Ac_Wc_Lc)	<ul style="list-style-type: none"> ▪ Ranipet, SIPCOT industrial complex
9	Singrauli (Uttar Pradesh) CEPI-81.73 (Ac_Wc_Ls)	<p>Sonebhadra (UP)</p> <ul style="list-style-type: none"> ▪ Dala-Tola ▪ Obra ▪ Renukoot ▪ Anpara ▪ Renusagar ▪ Kakri ▪ Dudhichuwa ▪ Bina ▪ Khadia ▪ Shakti nagar ▪ Rihand nagar ▪ Bijpur <p>Sigrauli (Madhya Pradesh)</p> <p>Vindhyachal nagar and Jaynat, Nigahi, Dudhichua, Amlohri & Jhingurdah townships</p>
10	Ludhiana (Punjab) CEPI-81.66 (Ac_Wc_Ls)	<p>Ludhiana municipal limits covering industrial clusters:</p> <ul style="list-style-type: none"> ▪ Focal point along with NH-I- Total eight phase ▪ Industrial area-B- from sherpur chowk to Gill road & Gill road to Miller Kotla road (left side of road) ▪ Mixed industrial area – right side of Gill road ▪ Industrial area –C (near Juglana village) ▪ Industrial area A & extension: area between old GT road and Ludhiana bypass road ▪ Industrial estate: near Dholwal chowk ▪ Mixes industrial area (MIA) Miller gunj ▪ MIA – bypass road ▪ Bahdur industrial area ▪ Tejpur industrial complex
11	Nazafgarh drain basin, Delhi CEPI-79.54 (As_Wc_Lc)	<ul style="list-style-type: none"> ▪ Industrial areas: Anand Parvat, Naraina, Okhla and Wazirpur
12	Noida (Uttar Pradesh) CEPI-78.90 (Ac_Wc_Lc)	<p>Territorial Jurisdiction of:</p> <ul style="list-style-type: none"> ▪ Noida Phase-1 ▪ Noida Phase-2 ▪ Noida Phase-3 ▪ Surajpur industrial area ▪ Greater Noida industrial area ▪ Village- Chhaparaula
13	Dhanbad (Jharkhand) CEPI-78.63 (Ac_Ws_Lc)	<p>Four blocks of Dhanbad district:</p> <ul style="list-style-type: none"> ▪ Sadar (Dhanbad Municipality) ▪ Jharia (Jharia Municipality, Sindri industrial area) ▪ Govindpur (Govindpur industrial estate) ▪ Nirsa
14	Dombivalli (Maharashtra) CEPI-78.41 (Ac_Wc_Ls)	<ul style="list-style-type: none"> ▪ MIDC Phase- I, Phase- II

15	Kanpur (Uttar Pradesh) CEPI-78.09 (Ac_Wc_Ls)	Industrial areas: <ul style="list-style-type: none"> ▪ Dada nagar ▪ Panki ▪ Fazalganj ▪ Vijay nagar ▪ Jajmau
16	Cuddalore (Tamil Nadu) CEPI-77.45 (As_Wc_Lc)	<ul style="list-style-type: none"> ▪ SIPCOT industrial complex, Phase I & II
17	Aurangabad (Maharashtra) CEPI-77.44 (Ac_Wc_Ls)	<ul style="list-style-type: none"> ▪ MIDC Chikhalthana, MIDC Waluj, MIDC Shendra, and Paithan road industrial area
18	Faridabad (Haryana) CEPI-77.07 (Ac_Ws_Lc)	<ul style="list-style-type: none"> ▪ Sector 27-A, B, C, D ▪ DLF phase- 1, sector 31,32 ▪ DLF phase- 2, sector 35 ▪ Sector 4, 6, 24, 27, 31, 59 ▪ Industrial area Hatin ▪ Industrial model township
19	Agra (Uttar Pradesh) CEPI-76.48 (As_Wc_Ls)	<ul style="list-style-type: none"> ▪ Nunihai industrial estate, Rambag nagar, UPSIDC industrial area, and Runukata industrial area
20	Manali (Tamil Nadu) CEPI-76.32 (Ac_Ws_Ls)	<ul style="list-style-type: none"> ▪ Manali industrial area
21	Haldia (West Bengal) CEPI-75.43 (As_Wc_Ls)	<ul style="list-style-type: none"> ▪ 5 km wide strip (17.4 x 5.0 km) of industrial area on the southern side of the confluence point of Rivers Hugli and Rupnarayan, covering ▪ Haldia municipal area & Sutahata block – I and II
22	Ahmedabad (Gujarat) CEPI-75.28 (Ac_Ws_Ls)	<ul style="list-style-type: none"> ▪ GIDC Odhav ▪ GIDC Naroda
23	Jodhpur (Rajasthan) CEPI-75.19 (As_Wc_Ls)	<ul style="list-style-type: none"> ▪ Industrial areas including Basni areas (phase-I & II), industrial estate, light & heavy industrial areas, industrial areas behind new power house, Mandore, Bornada, Sangariya and village Tanwada & Salawas. ▪ Jodhpur city
24	Greater Cochin (Kerala) CEPI-75.08 (As_Wc_Ls)	<ul style="list-style-type: none"> ▪ Eloor-Edayar industrial belt, ▪ Ambala Mogal industrial areas
25	Mandi Gobind Garh (Punjab) CEPI-75.08 (Ac_Ws_Lc)	<ul style="list-style-type: none"> ▪ Mandi Govindgarh municipal limit and khanna area
26	Howrah (West Bengal) CEPI-74.84 (As_Ws_Lc)	<ul style="list-style-type: none"> ▪ Liluah-Bamangachhi region, Howrah ▪ Jalan industrial complex-1, Howrah
27	Vatva (Gujarat) CEPI-74.77 (Ac_Wc_Ls)	<ul style="list-style-type: none"> ▪ GIDC Vatva, Narol industrial area (Villages Piplaj, Shahwadi, Narol)
28	Ib Valley (Orissa) CEPI-74.00 (Ac_Ws_Ls)	<ul style="list-style-type: none"> ▪ Ib Valley of Jharsuguda (Industrial and mining area)
29	Varansi-Mirzapur (Uttar Pradesh) CEPI-73.79 (As_Wc_Ls)	<ul style="list-style-type: none"> ▪ Industrial estate, Mirzapur ▪ Chunar ▪ Industrial estate, Chandpur, Varansi ▪ UPSIC, industrial estate, Phoolpur ▪ Industrial area, Ramnagar, Chandauli
30	Navi Mumbai (Maharashtra) CEPI-73.77 (Ac_Ws_Ls)	<ul style="list-style-type: none"> ▪ TTC industrial area, MIDC, Navi Mumbai (including Bocks-D, C, EL, A, R, General, Kalva)

31	Pali (Rajasthan) CEPI-73.73 (As_Wc_Ls)	<ul style="list-style-type: none"> ▪ Existing industrial areas: Mandia road, Puniyata road, Sumerpur ▪ Pali town
32	Mangalore (Karnataka) CEPI-73.68 (Ac_Ws_Ls)	<ul style="list-style-type: none"> ▪ Baikampady industrial area
33	Jharsuguda (Orissa) CEPI-73.34 (Ac_Ws_Ls)	<ul style="list-style-type: none"> ▪ Ib valley of Jharsuguda (Industrial and mining area)
34	Coimbatore (Tamil Nadu) CEPI-72.38 (Ac_Ws_Ln)	<ul style="list-style-type: none"> ▪ SIDCO, Kurichi industrial Clusters
35	Bhadravati (Karnataka) CEPI-72.33 (Ac_Ws_Ln)	<ul style="list-style-type: none"> ▪ KSSIDC Industrial area, Mysore paper mill & VISL township complex
36	Tarapur (Maharashtra) CEPI-72.01 (Ac_Ws_Ls)	<ul style="list-style-type: none"> ▪ MIDC Tarapur
37	Panipat (Haryana) CEPI-71.91 (As_Ws_Ls)	<ul style="list-style-type: none"> ▪ Panipat municipal limit and its industrial clusters
38	Indore (Madhya Pradesh) CEPI-71.26 (As_Ws_Ls)	<p>Following 09 industrial area:</p> <ul style="list-style-type: none"> ▪ Sanwer road ▪ Shivaji nagar ▪ Pologround ▪ Laxmibai nagar ▪ Scheme no.71 ▪ Navlakha ▪ Pipliya ▪ Palda ▪ Rau <p>Indore city</p> <p>Other surrounding industrial areas: Manglia, Rajoda, Asrawad, Tejpur Gadwadi</p>
39	Bhavnagar (Gujarat) CEPI-70.99 (As_Ws_Ls)	<ul style="list-style-type: none"> ▪ GIDI Chitra, Bhavnagar
40	Vishakhapatnam (Andhra Pradesh) CEPI-70.82 (As_Ws_Ls)	<ul style="list-style-type: none"> ▪ Bowl area (the area between Yarada hill range in the south to Simhachalam hill range in the north and sea on the east and the present NH-5 in the west direction)
41	Junagarh (Gujarat) CEPI-70.82 (As_Ws_Ls)	<p>Industrial areas:</p> <ul style="list-style-type: none"> ▪ Sabalpur ▪ Jay Bhavani ▪ Jay Bhuvneshwari ▪ GIDC Junagarh (I&II)
42	Asansole (West Bengal) CEPI-70.20 (As_Ws_Ls)	<ul style="list-style-type: none"> ▪ Bumpur area surrounding IISCO
43	Patancheru - Bollaram (Andhra Pradesh) CEPI-70.07 (As_Ws_Ls)	<p>Industrial area:</p> <ul style="list-style-type: none"> ▪ Patancheru ▪ Bollaram

Note:

Names of identified industrial clusters/potential impact zones are approximate location based on rapid survey and assessment and may alter partially subject to the detailed field study and monitoring. Detailed mapping will be made available showing spatial boundaries of the identified industrial clusters including zone of influence/ buffer zone, after in depth field study.

ANNEXURE V
Pre-Feasibility Report: Points for Possible Coverage

Pre-Feasibility Report: Points for Possible Coverage

S. No.	Contents	Points of Coverage in Pre-feasibility Report
I.	Executive Summary	<ul style="list-style-type: none"> ▪ A miniature report of entire pre feasibility report.
II.	Project Details	
	Need/Justification of the Project	<ul style="list-style-type: none"> ▪ Current demand scenario of the product ▪ Alternatives to meet the demand ▪ Post project scenario on residual demand
	Capacity of Coke Oven Plant	<ul style="list-style-type: none"> ▪ Production capacity of the industry ▪ Sustainability of raw material supply and quality ▪ Optimization of plant capacity
	Process technology	<ul style="list-style-type: none"> ▪ Analysis of available/advanced technologies, etc. ▪ Analysis of possible configurations for each technology or a combination of these ▪ Broad specifications for the proposed industrial units including process technologies/equipments
	Resources/raw materials	<ul style="list-style-type: none"> ▪ Details on raw material, by products <ul style="list-style-type: none"> - Water - Water requirement for process, utilities, domestic, gardening etc. - Source of construction water and potable water - Source of circulating/consumptive water - Quality of raw water, treated water - Water budget calculations and effluent generation - Approved water allocation quota (drinking, irrigation and industrial use) and surplus availability - Feasible ways of bringing water to site indicating constraints if any. - Lean season water availability and allocation source in case main source not perennial. ▪ Manpower ▪ Infrastructure ▪ Electrical power ▪ Construction material like sand, brick, stone chips, borrow earth etc.
	Rejects (Pollution potential)	<ul style="list-style-type: none"> ▪ Air emissions (VOCs, HAPs, Dioxins and furans, metals, Chlorides and fluorides, <i>etc.</i>) ▪ Water pollution ▪ Solid / hazardous waste (slag, steel skulls, waste refractories, sludge, <i>etc.</i>) ▪ Noise ▪ Odour
	Technical profile	<ul style="list-style-type: none"> ▪ Construction details <ul style="list-style-type: none"> - Estimated duration - Number of construction workers including migrating workers - Construction equipment - Vehicular traffic - Source, mode of transportation and storage of construction material ▪ Traffic that would arise during different phases of the project and transportation mechanism to handle such traffic ▪ New facilities needed ▪ Technical parameters of the plant & equipments to be

		<ul style="list-style-type: none"> used ▪ Product storage and associated transportation system ▪ Product demand & supply position data on regional basis
	Project schedule	<ul style="list-style-type: none"> ▪ Project implementation schedule
	Future prospects	<ul style="list-style-type: none"> ▪ Ascertain the costs and benefits of the proposed project for project life ▪ Technical and logistic constraints/ requirements of project sustainability
III.	Selection of site based on least possible impacts	
i.	Choice of site selection	
	Major techno-economic feasibility considerations	<ul style="list-style-type: none"> ▪ Land availability & its development ▪ Product demand around the selected site ▪ Access to site for transportation of equipments/ construction machinery, material, etc. ▪ Raw material availability and its transportation ▪ Water availability and consumptive use ▪ Product transportation ▪ Infrastructure availability at selected site ▪ Inter-state issue, if any
	Incompatible landuse and ecologically sensitive attributes with respect to identified suitable sites	<ul style="list-style-type: none"> ▪ If any incompatible land-use attributes fall within the study area, the following details has to be provided: <ul style="list-style-type: none"> - Public water supply areas from rivers/surface water bodies, from groundwater - Scenic areas/tourism areas/hill resorts - Religious places, pilgrim centers that attract over 10 lakh pilgrims a year - Protected tribal settlements (notified tribal areas where industrial activity is not permitted); CRZ - Monuments of national significance, World Heritage Sites - Cyclone, Tsunami prone areas (based on last 25 years); - Airport areas - Any other feature as specified by the State or local government and other features as locally applicable, including prime agricultural lands, pastures, migratory corridors, etc. ▪ If ecologically sensitive attributes fall within the study area, please give details. Ecologically sensitive attributes include <ul style="list-style-type: none"> - National parks - Wild life sanctuaries Game reserve - Tiger reserve/elephant reserve/turtle nesting ground - Mangrove area - Wetlands - Reserved and protected forests - Endangered species of flora and fauna - Any other eco-sensitive areas <i>etc.</i>
	Social aspects	<ul style="list-style-type: none"> ▪ Corporate social responsibilities ▪ Employments and infrastructure added in the vicinity of the plant ▪ Status of land availability, current and post project land use variation ▪ Social sensitivity and likely project affected people

ii.	Details of selected site	
	Land details	<ul style="list-style-type: none"> ▪ Land requirement and availability ▪ Land ownership details such as Government, private, tribal, non-tribal, etc. ▪ Total area of the project/site ▪ Prevailing land cost details
	Location	<ul style="list-style-type: none"> ▪ Geographical details - Longitude & latitude, village, taluka, district, state ▪ Approach to site – roads, railways and airports ▪ Distance from nearest residential and industrial areas ▪ Distance from nearest water bodies such as river, canal, dam, etc ▪ Distance from ecologically sensitive areas ▪ In case of flood prone areas, HFL of the site ▪ In case of seismic areas, seismic zone, active faults, occurrence on earthquakes, <i>etc.</i> ▪ Proximity from infrastructural facilities
	Physical characteristics	<ul style="list-style-type: none"> ▪ Demography ▪ Meteorological data ▪ Landuse pattern such as agricultural, barren, forest, etc. and details thereof ▪ Topography of the area ▪ Drainage patterns ▪ Soil condition and soil investigation results ▪ Ground profile and levels
IV.	Anticipated impacts based on project operations on receiving environment	<ul style="list-style-type: none"> ▪ Population ▪ Flora and fauna ▪ Water ▪ Soil ▪ Air ▪ Climate ▪ Landscape, etc.
V.	Proposed broad mitigation measures which could effectively be internalized as project components to have environmental and social acceptance of the proposed site	<ul style="list-style-type: none"> ▪ Preventive measures ▪ Source control measures ▪ Mitigation measures at the receiving environment, etc.
VI.	An indication of any difficulties (technical deficiencies or lack of know-how) encountered by the developer in compiling the required information.	

The above listing is not exhaustive. Thus the proponent may provide additional necessary information, felt appropriate, to include in the pre-feasibility study report in support of selecting the site for the proposed developmental activities. The Concerned EAC/SEAC during scrutiny, may specifically ask for any additional information/data required to substantiate the requirement to prescribe the ToR for EIA studies. However, it is to make clear that all the required further information by EAC/SEAC may be mentioned in one single letter, within the prescribed time.

ANNEXURE VI
Types of Monitoring and Network Design Considerations

TYPES OF MONITORING AND NETWORK DESIGN CONSIDERATIONS

A. Types of Monitoring

Monitoring refers to the collection of data using a series of repetitive measurements of environmental parameters (or, more generally, to a process of systematic observation). The environmental quality monitoring programme design will be dependent upon the monitoring objectives specified for the selected area of interest. The main types of EIA monitoring activities are:

- Baseline monitoring is the measurement of environmental parameters during the pre-project period for the purpose of determining the range of variation of the system and establishing reference points against which changes can be measured. This leads to the assessment of the possible (additional available) assimilative capacity of the environmental components in pre-project period w.r.t. the standard or target level.
- Effects monitoring is the measurement of environmental parameters during project construction and implementation to detect changes which are attributable to the project to provide the necessary information to:
 - verify the accuracy of EIA predictions; and
 - determine the effectiveness of measures to mitigate adverse effects of projects on the environment.
 - Feedback from environmental effect monitoring programs may be used to improve the predictive capability of EIAs and also determine whether more or less stringent mitigation measures are needed
- Compliance monitoring is the periodic sampling or continuous measurement of environmental parameters to ensure that regulatory requirements and standards are being met.

Compliance and effects monitoring occurs during the project construction, operation, and abandonment stages. The resources and institutional set-up should be available for the monitoring at these stages. All large-scale construction projects will require some construction stage monitoring. To control the environmental hazards of construction as specified in the EIA, a monitoring program should be established to ensure that each mitigation measure is effectively implemented. There are numerous potential areas for monitoring during operations.

It is meaningful to perform baseline monitoring at those stations where the effects monitoring is to be performed so that the change from baseline due to the project as predicted by models can be validated and rectification can be performed even after the project starts functioning. It is therefore necessary to select the base line stations at those places where the predicted effects will be very high. The scope of monitoring topics discussed in this chapter is limited to Baseline and Effects monitoring. In addition, this chapter will also discuss the Compliance monitoring during the construction phase. Post-project monitoring requirements are discussed in the EMP.

Before any field monitoring tasks are undertaken there are many institutional, scientific, and fiscal issues that must be addressed in the implementation of an environmental monitoring program. Careful consideration of these issues in the design and planning stages will help avoid many of the pitfalls associated with environmental monitoring programs. Although these issues are important but the discussions here are confined to the monitoring network design component.

B. Network Design

Analysis of Significant Environmental Issues

At the outset of planning for an environmental monitoring network, the EIA manager may not know exactly what should be monitored, when monitoring should begin, where it should monitor, which techniques should be employed, and who should take responsibility for its conduct. Because there are usually a number of objective decisions associated with network design to be made, it is important to start with an analysis of environmental issues. The scoping phase of an EIA is designed to identify and focus on the major issues. Scoping should provide a valuable source of information on the concerns that need to be addressed by the monitoring network design. These are project specific as well as specific to the environmental setting of the location where the project is proposed to be located

Hence, the network designs are associated with questions like:

- What are the expected outputs of the monitoring activity?
- Which problems do we need to address to? *etc.*

Defining the output will influence the design of the network and optimize the resources used for monitoring. It will also ensure that the network is specially designed to optimize the information on the problems at hand

What to Monitor?

The question of what to monitor is associated with the identification of VECs.

VECs are generally defined as environmental attributes or components of the environment that are valued by society as identified during the scoping stage of the project. They are determined on the basis of perceived public concerns. For example, changes to water quality and quantity could have implications on fish by affecting habitat, food supply, oxygen, and contaminant uptake. Similarly, employment and business, and economies are both VECs that serve as pathways.

The choice of VECs is also related to the perceived significant impact of the project implementation on important environmental components. In general, the significance or importance of environmental components is judged based on:

- legal protection provided (for example, rare and endangered species)
- political or public concerns (for example, resource use conflicts and sustainable development)
- scientific judgment (for example, ecological importance); or
- commercial or economic importance

However, in addition to their economic, social, political or ecological significance, the chosen VEC should also have unambiguous operational ease, be accessible to prediction and measurement; and be susceptible to hazard. Once the VECs are defined, the VECs may be directly measured (for example, extent of habitat for an endangered species). In cases where it is impossible or impractical to directly measure the VECs, the chosen measurement endpoints or environmental indicators must correspond to, or be predictive of assessment endpoints.

The chosen environmental indicators must be: 1) measurable; 2) appropriate to the scale of disturbance/ contamination; 3) appropriate to the impact mechanism; 4) appropriate

and proportional to temporal dynamics; 5) diagnostic; and 6) standardized; as well as have: 1) a low natural variability; 2) a broad applicability; and 3) an existing data series.

C. Site Selection

This normally means that for designing a monitoring programme in an (study) area which might have an impact, several monitoring stations are needed for characterizing the baseline conditions of the impacted area. When considering the location of individual samplers, it is essential that the data collected are representative for the location and type of area without the undue influence from the immediate surroundings. In any measurement point in the study area the total ambient concentration is the representative of:

- natural background concentration
- regional background
- impact of existing large regional sources such as Industrial emissions and other power plants

To obtain the information about the importance of these different contributions it is therefore necessary to locate monitoring stations so that they are representative for different impacts. In addition to the ambient pollution data, one would often need other data governing the variations such as meteorological data for air pollution, to identify and quantify the sources contributing to the measurements. When considering the location of individual samplers, it is essential that the data collected are representative for the location and type of area without undue influence from the immediate surroundings. For example, for measuring natural background concentration, if a dust sampler is located adjacent to a dusty road at road level, this will read occasional traffic pollution rather than the general background dust level of the area. As such a proper QA/QC must be followed to locate stations. USEPA guidelines are available for this.

Where, How and How Many Times to Monitor?

These are the other components of Monitoring Network Design. These questions are best answered based on local field conditions, capacity and resources available, prevailing legal and regulatory priorities, *etc.* For this screening or reconnaissance Surveys of the study area also necessary. This may also include some simple inexpensive measurements and assimilative/dispersion modeling. The data will give some information on the prevailing spatial and temporal variations, and the general background air pollution in the area. The number of monitoring stations and the indicators to be measured at each station in the final permanent network may then be decided upon based on the results of the screening study as well as on the knowledge of the sources of the proposed development and prevailing local environmental/meteorological conditions. The best possible definition of the air pollution problem, together with the analysis of the resources: personnel, budget and equipment available, represent the basis for the decision on the following questions:

- What spatial density (number) of sampling stations is required?

It is evident that the more is the number of stations selected in the study area, the more representative is the data and the more is the cost of monitoring. Therefore this needs optimization. For example, for optimum results as per the present practice, for medium sized plants like a stand alone coke oven plant, the study area is a circle of 10 km radius from the plant centre; the number of AAQ stations are at least 6; the number of meteorological station may be 1 in case the study area falls in a single air shed having similar meteorological conditions and more in case the study area falls in more than one air sheds; the number of surface water quality stations will depend on the number of

surface water bodies present in the study area and likely to get polluted; the number of ground water stations may be at least 6 to 8; the number of noise monitoring stations will depend upon the number of residential, commercial and sensitive areas likely to get affected due to the noise from the plant operation and its services facilities like transport; the number of soil monitoring stations will be those agricultural lands where the dust fall from the plant is likely to be high; the number of ecological monitoring stations will depend upon the number of ecologically sensitive spots etc. Qualitative and quantitative models may be used to defend the decision. However, these optimum figures are not statutory requirements and may change from time to time as more scientific and credible information becomes available. These must be presented in the ToR before costly monitoring exercise is started to save repetitions. For details refer Annexure 4.

- How many samples are needed and during what period (sampling (averaging) time and frequency)?

These are mostly governed by statutory stipulations made in the E(P) Act/ EIA Notification/ EIA questionnaire. These must be presented in the ToR before costly monitoring exercise is started to save repetitions. Generally, the sampling averaging time must be compatible with the norms e.g., 24 hrs average for AAQ for SPM/RPM/SO₂/NO_x/Pb/Benzo(A) Pyrene and 1/8 hrs for CO; twice a week for at least one full season of 3 months except monsoon equally spaced. Met data should be hourly to be compatible with dispersion models. Water samples should be grab or composite for flowing water collected over the sampling period of one full season and ground water for pre and post monsoon to give more representative data. LEQ noise should be collected on limited days over 24 hours to obtain night time and day time values. Dust fall should be collected monthly for 3 months of monitoring period. As work zone, stack, ecological and socio economic monitoring are not much season oriented, they may be collected at the earliest. For details refer Annexure 4.

- Where should the stations be located?

As described, the location should be the worst affected areas due to plant operation. As such for AAQ monitoring, a qualitative or quantitative screening model may be used to identify inhabited localities/ sensitive locations/ areas under surveillance with limited met and emission data where GLC due to plant operation will be very high; for surface water monitoring all static water bodies, upstream and down stream of flowing water bodies from locations of probable discharges; all upstream and downstream ground water bodies from probable locations of leaching possibilities (for this ground water contours of the area should be pre determined); all ecologically sensitive areas; residential/commercial/sensitive locations for noise monitoring; prime agricultural lands for dust fall monitoring etc. In general, there must be a scientific basis for selecting locations. These must be presented in the ToR before costly monitoring exercise is started to save repetitions. For details refer Annexure 4.

- What kind of equipment should be used?

The CPCB guidelines describe such equipment and methods in details. In addition, standard literatures/ handbooks like USEPA/APHA handbooks may be referred. For details refer Annexure 4.

- What additional background information is needed?
 - Published meteorological data from IMD's nearest station
 - Topography from Survey of India/ satellite imageries
 - population density from latest government publications
 - emission sources and emission rates of plant proper/ other nearby plants affecting study area
 - effects and impacts

- ground water contours
- data on forest and ecology from forest department
- upper air data- primary or secondary
- any other secondary information

- How will the data be made available/communicated?

All raw data must be preserved. Adequate QA/QC may be followed. Summary data may be included in the EIA.

ANNEXURE VII
Guidance for Assessment of Baseline Components and Attributes

GUIDANCE FOR ASSESSMENT OF BASELINE COMPONENTS AND ATTRIBUTES*

Attributes	Sampling		Measurement Method	Remarks
	Network	Frequency		
A. Air				
<ul style="list-style-type: none"> ▪ Meteorological ▪ Wind speed ▪ Wind direction ▪ Dry bulb temperature ▪ Wet bulb temperature ▪ Relative humidity ▪ Rainfall ▪ Solar radiation ▪ Cloud cover 	<p>Minimum 1 site in the project impact area requirements</p> <p>Other additional site(s) are require depending upon the model applied or site sensitivities</p>	<p>Min: 1 hrly observations from continuous records</p>	<p>Mechanical / automatic weather station</p> <p>Rain gauge</p> <p>As per IMD</p> <p>As per IMD</p>	<p>IS 5182 Part 1-20 Sit-specific primary data is essential</p> <p>Secondary data from IMD, New Delhi for the nearest IMD station</p>
<p>Pollutants</p> <ul style="list-style-type: none"> ▪ SPM ▪ RPM ▪ SO₂ ▪ NO₂ ▪ CO ▪ H₂S* ▪ NH₃* ▪ HC* ▪ Fluoride* ▪ Pb* ▪ VOC-PAH* ▪ Mercury* <p>(parameters to be proposed by the proponent, in draft ToR, which will be reviewed and approved by EAC/SEAC)</p>	<p>10 to 15 locations in the project impact area</p>	<p>24 hrly twice a week</p> <p>8 hrly twice a week</p> <p>24 hrly twice a week</p>	<ul style="list-style-type: none"> ▪ Gravimetric (High – Volume) ▪ Gravimetric (High – Volume with Cyclone) ▪ EPA Modified West & Gaeke method ▪ Arsenite Modified Jacob & Hochheiser ▪ NDIR technique ▪ Methylene-blue ▪ Nessler’s Method ▪ Infra Red analyzer ▪ Specific Ion meter 	<p>Monitoring Network</p> <ul style="list-style-type: none"> ▪ Minimum 2 locations in upwind side, more sites in downwind side / impact zone ▪ All the sensitive receptors need to be covered <p>Measurement Methods</p> <p>As per CPCB standards for NAQM, 1994</p>

Attributes	Sampling		Measurement Method	Remarks
	Network	Frequency		
B. Noise				
Hourly equivalent noise levels	Same as for Air Pollution along with others Identified in study area	At least one day continuous in each season on a working and non-working day	Instrument : Sensitive Noise level meter (preferably recording type)	Min: IS: 4954- 1968 as adopted by CPCB
Hourly equivalent noise levels	Inplant (1.5 m from machinery or high emission processes)	Same as above for day and night	Instrument : Noise level metre	CPCB / OSHA
Hourly equivalent noise levels	Highways (within 500 metres from the road edge)	Same as above for day and night	Instrument : Noise level meter	CPCB / IS : 4954-1968
Peak particle velocity	150- 200m from blast site	Based on hourly observations	PPV meter	
C. Water				
Parameters for water quality <ul style="list-style-type: none"> ▪ Ph, temp, turbidity, magnesium hardness, total alkalinity, chloride, sulphate, nitrate, fluoride, sodium, potassium salinity ▪ Total nitrogen, total phosphorus, DO, BOD, COD, Phenol ▪ Heavy metals ▪ Total coliforms, faecal coliforms ▪ Phyto plankton ▪ Zooplankton ▪ Fish & other aquatic flora & fauna (parameters are given in ToR for EIA studies based on nature of project, raw material & process)	Set of grab samples during pre and post- monsoon for ground and surface water for the whole study zone. For lab. Analysis the samples should be preserved for transport safe	Diurnal and season-wise	Samples for water quality should be collected and analyzed as per: IS: 2488 (Part 1-5) methods for sampling and testing of industrial effluents Standard methods for examination of water and waste water analysis published by American Public Health Association. International standard practices for benthos and aquatic flora & fauna	

Attributes	Sampling		Measurement Method	Remarks
	Network	Frequency		
technology, location-nature/activities within of air basin)				
For Surface Water Bodies				
<ul style="list-style-type: none"> ▪ Total Carbon ▪ PH ▪ Dissolved Oxygen ▪ Biological Oxygen Demand ▪ Free NH₄ ▪ Boron ▪ Sodium Absorption ratio ▪ Electrical Conductivity 	<p>Monitoring locations should include up-stream, on site, down stream of proposed discharge point. Besides sampling should cover width of the river in case water quality modeling is proposed.</p> <p>Standard methodology for collection of surface water (BIS standards)</p> <p>At least one grab sample per location per season</p>	<p>Yield & impact on water sources to be measured during critical season</p> <p>River Stretch within project area be divided in grids (say 1 km length and 1/3 width) and samples should be from each grid at a time when the wastewater discharged by other sources of pollution is expected to be maximum</p>	<p>Samples for water quality should be collected and analyzed as per: IS: 2488 (Part 1-5) methods for sampling and testing of industrial effluents</p> <p>Standard methods for examination of water and wastewater analysis published by American Public Health Association.</p>	<p>Historical data should be collected from relevant offices such as central water commission, state and central ground water board, Irrigation dept.</p>
Parameters for wastewater characterization				
<ul style="list-style-type: none"> ▪ Temp, colour, odour, turbidity, TSS, TDS ▪ PH , alkalinity as CaCO₃, p value, M value, total hardness as CaCO₃, chloride as cl, sulphate as S₀₄, Nitrate as NO₃, Floride as F, Phosphate as P₀₄, Chromium as Cr (Hexavalent, total) Ammonical Nitrogen as N, TKN, % sodium, BOD at 20 C, COD, DO, total residual chlorine as Cl₂, oil and grease, sulphide, phenolic compound 	<p>Implant Source depending upon the different waste streams the parameters can be optimized</p> <p>Grab and composite sampling representing avg of different process operations as well as worst emission scenario should be represented</p>	<p>Different operational cycles as well as raw material variations should be reflected in the analysis</p>	<p>Samples for water quality should be collected and analyzed as per: IS: 2488 (Part 1-5) methods for sampling and testing of industrial effluents</p> <p>Standard methods for examination of water and wastewater analysis published by American Public Health Association.</p>	<p>All plant sources categorized as:</p> <ul style="list-style-type: none"> ▪ Different Process waste streams as well as run-off conditions ▪ ETP wastewater <p>Domestic/ sanitary wastewater</p>

Attributes	Sampling		Measurement Method	Remarks
	Network	Frequency		
D. Land Environment				
<ul style="list-style-type: none"> ▪ Soil ▪ Particle size distribution ▪ Texture ▪ pH ▪ Electrical conductivity ▪ Cation exchange capacity ▪ Alkali metals ▪ Sodium Absorption Ratio (SAR) ▪ Permeability ▪ Porosity 	One surface sample from each landfill and/or hazardous waste site (if applicable) and prime villages, (soil samples be collected as per BIS specifications) in the study area	Season-wise	Collected and analyzed as per soil analysis reference book, M.I.Jackson and soil analysis reference book by C.A. Black	The purpose of impact assessment on soil (land environment) is to assess the significant impacts due to leaching of wastes or accidental releases and contaminating
Landuse / Landscape				
<ul style="list-style-type: none"> ▪ Location code ▪ Total project area ▪ Topography ▪ Drainage (natural) ▪ Cultivated, forest plantations, water bodies, roads and settlements 	At least 20 points along with plant boundary and general major land use categories in the study area.	Drainage once in the study period and land use categories from secondary data (local maps) and satellite imageries	<ul style="list-style-type: none"> ▪ Global positioning system ▪ Topo-sheets ▪ Satellite Imageries (1:25,000) ▪ Satellite Imageries (1:25,000) 	<p>Drainage within the plant area and surrounding is very important for storm water impacts.</p> <p>From land use maps sensitive receptors (forests, parks, mangroves etc.) can be identified</p>
E. Solid Waste				
<p>Quantity:</p> <ul style="list-style-type: none"> ▪ Based on waste generated from per unit production ▪ Per capita contribution ▪ Collection, transport and disposal system ▪ Process Waste ▪ Quality (oily, chemical, biological) 	For green field units it is based on secondary data base of earlier plants.	Process wise or activity wise for respective raw material used. Domestic waste depends upon the season also	<p>Guidelines</p> <p>IS 9569 : 1980</p> <p>IS 10447 : 1983</p> <p>IS 12625 : 1989</p> <p>IS 12647 : 1989</p> <p>IS 12662 (PTI) 1989</p>	

Attributes	Sampling		Measurement Method	Remarks
	Network	Frequency		
Quality: <ul style="list-style-type: none"> ▪ General segregation into biological/organic/inert/hazardous ▪ Loss on heating ▪ pH ▪ Electrical Conductivity ▪ Calorific value, metals etc. 	Grab and Composite samples	Process wise or activity wise for respective raw material used. Domestic waste depends upon the season also	Analysis IS 9334 : 1979 IS 9235 : 1979 IS 10158 : 1982	
Hazardous Waste				
<ul style="list-style-type: none"> ▪ Permeability And porosity ▪ Moisture pH ▪ Electrical conductivity ▪ Loss on ignition ▪ Phosphorous ▪ Total nitrogen ▪ Cation exchange capacity ▪ Particle size distribution ▪ Heavy metal ▪ Ansonia ▪ Fluoride 	Grab and Composite samples. Recyclable components have to analyzed for the recycling requirements	Process wise or activity wise for respective raw material used.	Analysis IS 9334 : 1979 IS 9235 : 1979 IS 10158 : 1982	Impacts of hazardous waste should be performed critically depending on the waste characteristics and place of discharge. For land disposal the guidelines should be followed and impacts of accidental releases should be assessed
F. Biological Environment Aquatic				
<ul style="list-style-type: none"> ▪ Primary productivity ▪ Aquatic weeds ▪ Enumeration of phytoplankton, zooplankton and benthos ▪ Fisheries ▪ Diversity indices 	Considering probable impact, sampling points and number of samples to be decided on established guidelines on ecological studies based on site eco-environment setting within 10/25 km radius from the	Season changes are very important	Standards techniques (APHA et. Al. 1995, Rau and Wooten 1980) to be followed for sampling and measurement	Seasonal sampling for aquatic biota One season for terrestrial biota, in addition to vegetation studies during monsoon season Preliminary assessment

Attributes	Sampling		Measurement Method	Remarks
	Network	Frequency		
<ul style="list-style-type: none"> ▪ Trophic levels ▪ Rare and endangered species ▪ Sanctuaries / closed areas / Coastal regulation zone (CRZ) ▪ Terrestrial ▪ Vegetation – species, list, economic importance, forest produce, medicinal value ▪ Importance value index (IVI) of trees ▪ Wild animals 	<p>proposed site</p> <p>Samples to collect from upstream and downstream of discharge point, nearby tributaries at down stream, and also from dug wells close to activity site</p>			<p>Microscopic analysis of plankton and meiobenthos, studies of macrofauna, aquatic vegetation and application of indices, viz. Shannon, similarity, dominance IVI etc</p> <p>Point quarter plot-less method (random sampling) for terrestrial vegetation survey.</p>
<p>Avifauna</p> <ul style="list-style-type: none"> ▪ Rare and endangered species ▪ Sanctuaries / National park / Biosphere reserve 	<p>For forest studies, chronic as well as short-term impacts should be analyzed warranting data on micro climate conditions</p>			<p>Secondary data to collect from Government offices, NGOs, published literature</p> <p>Plankton net</p> <p>Sediment dredge</p> <p>Depth sampler</p> <p>Microscope</p> <p>Field binocular</p>
G. Socio Economic				
<ul style="list-style-type: none"> ▪ Demographic structure ▪ Infrastructure resource base ▪ Economic resource base ▪ Health status: Morbidity pattern ▪ Cultural and aesthetic attributes 	<p>Socio-economic survey is based on proportionate, stratified and random sampling method</p>	<p>Different impacts occurs during construction and operational phases of the project</p>	<p>Primary data collection through R&R surveys (if require) or community survey are based on personal interviews and questionnaire</p>	<p>Secondary data from census records, statistical hard books, toposheets, health records and relevant official records available with Govt. agencies</p>

* Project Specific concerned parameters needs to be identified by the project proponent and shall be incorporated in the draft ToR, to be submitted to the Authority for the consideration and approval by the EAC/SEAC.

ANNEXURE VIII
Sources of Secondary Data

Annexure VIIIA: Potential Sources of Data For EIA

Information	Source
Air Environment	
1. Meteorology- Temperature, Rainfall, Humidity, Inversion, Seasonal Wind rose pattern (16 point compass scale), cloud cover, wind speed, wind direction, stability, mixing depth	<ul style="list-style-type: none"> ⊗ Indian Meteorology Department, Pune
2. Ambient Air Quality- 24 hourly concentration of SPM, RPM, SO ₂ , NO _x , CO	<ul style="list-style-type: none"> ⊗ Central Pollution Control Board (CPCB), ⊗ State Pollution Control Board (SPCB), ⊗ Municipal Corporations ⊗ Ministry of Environment and Forests (MoEF) ⊗ State Department of Environment (DoEN)
Water Environment	
3. Surface water- water sources, water flow (lean season), water quality, water usage, Downstream water users Command area development plan Catchment treatment plan	<ul style="list-style-type: none"> ⊗ Central Water Commission (CWC), ⊗ Central Pollution Control Board (CPCB), ⊗ State Pollution Control Board (SPCB), Central Water and Power Research Institute (CWPRS), Pune ⊗ State Irrigation Department ⊗ Hydel Power generation organizations such as NHPC, State SEBs
4. Ground Water- groundwater recharge rate/withdrawal rate, ground water potential groundwater levels (pre monsoon, post monsoon), ground water quality, changes observed in quality and quantity of ground water in last 15 years	<ul style="list-style-type: none"> ⊗ Central Ground Water Board (CGWB) ⊗ Central Ground Water Authority (CGWA) ⊗ State Ground Water Board (SGWB) ⊗ National Water Development Authority (NWDA)
5. Coastal waters- water quality, tide and current data, bathymetry	<ul style="list-style-type: none"> ⊗ Department of Ocean Development, New Delhi ⊗ State Maritime Boards ⊗ Naval Hydrographer's Office, Dehradun ⊗ Port Authorities ⊗ National Institute of Oceanography (NIO), Goa
Biological Environment	
6. Description of Biological Environment- inventory of flora and fauna in 7 km radius, endemic species, endangered species, Aquatic Fauna, Forest land, forest type and density of vegetation, biosphere, national parks, wild life sanctuaries, tiger reserve, elephant reserve, turtle nesting ground, core zone of biosphere reserve, habitat of migratory birds, routes of migratory birds	<ul style="list-style-type: none"> ⊗ District Gazetteers ⊗ National Remote Sensing Agency (NRSA), Hyderabad ⊗ Forest Survey of India, Dehradun ⊗ Wildlife Institute of India ⊗ World Wildlife Fund ⊗ Zoological Survey of India ⊗ Botanical Survey of India ⊗ Bombay Natural History Society, (BNHS), Mumbai ⊗ State Forest Departments ⊗ State Fisheries Department ⊗ Ministry of Environment and Forests ⊗ State Agriculture Departments ⊗ State Agriculture Universities
Land Environment	
7. Geographical Information-Latitude, Longitude, Elevation (above MSL)	<ul style="list-style-type: none"> ⊗ Toposheets of Survey of India, Pune ⊗ National Remote Sensing Agency (NRSA), Hyderabad ⊗ Space Application Centre (SAC), Ahmedabad

Information	Source
8. Nature of Terrain, topography map indicating contours (1:2500 scale)	<ul style="list-style-type: none"> ⑨ Survey of India Toposheets ⑨ National Remote Sensing Agency (NRSA), Hyderabad ⑨ State Remote Sensing Centre, ⑨ Space Application Centre (SAC), Ahmedabad
9. Hydrogeology- Hydrogeological report (in case of ground water is used/area is drought prone/wastewater is likely to discharged on land) Geomorphological analysis (topography and drainage pattern) Geological analysis (Geological Formations/Disturbances- geological and structural maps, geomorphological contour maps, structural features, including lineaments, fractures, faults and joints) Hydrogeological analysis (disposition of permeable formations, surface-ground water links, hydraulic parameter determination etc) Analysis of the natural soil and water to assess pollutant absorption capacity	<ul style="list-style-type: none"> ⑨ NRSA, Hyderabad ⑨ Survey of India Toposheets ⑨ Geological Survey of India ⑨ State Geology Departments ⑨ State Irrigation Department ⑨ Department of Wasteland Development, Ministry of Rural Areas ⑨ National Water Development Authority (NWDA)
10. Nature of Soil, permeability, erodibility classification of the land	<ul style="list-style-type: none"> ⑨ Agriculture Universities ⑨ State Agriculture Department ⑨ Indian Council for Agriculture Research ⑨ State Soil Conservation Departments ⑨ National Bureau of Soil Survey and Landuse Planning ⑨ Central Arid Zone Research Institute (CAZRI), Jodhpur
11. Landuse in the project area and 10 km radius of the periphery of the project	<ul style="list-style-type: none"> ⑨ Survey of India- Toposheets ⑨ All India Soil and Landuse Survey; Delhi ⑨ National Remote Sensing Agency (NRSA), Hyderabad ⑨ Town and County Planning Organisation ⑨ State Urban Planning Department ⑨ Regional Planning Authorities (existing and proposed plans) ⑨ Village Revenue Map- District Collectorate ⑨ Directorate of Economics and Statistics-State Government ⑨ Space Application Centre, Ahmedabad
12. Coastal Regulation Zones- CRZMP, CRZ classification, Demarcation of HTL and LTL*	<ul style="list-style-type: none"> ⑨ Urban Development Department ⑨ State Department of Environment ⑨ State Pollution Control Board ⑨ Space Application Centre* ⑨ Centre for Earth Sciences Studies, Thiruvanthapuram* ⑨ Institute of Remote Sensing, Anna University Chennai* ⑨ Naval Hydrographer's Office, Dehradun* ⑨ National Institute of Oceanography, Goa* ⑨ National Institute of Ocean Technology, Chennai ⑨ Centre for Earth Science Studies

* Agencies authorized for approval of demarcation of HTL and LTL

Information	Source
Social	
13. Socioeconomic - population, number of houses and present occupation pattern within 7 km from the periphery of the project	<ul style="list-style-type: none"> ⊗ Census Department ⊗ District Gazetteers- State Government ⊗ District Statistics- District Collectorate ⊗ International Institute of Population Sciences, Mumbai (limited data) ⊗ Central Statistical Organisation
14. Monuments and heritage sites	<ul style="list-style-type: none"> District Gazetteer Archeological Survey of India, INTACH District Collectorate Central and State Tourism Department State Tribal and Social Welfare Department
Natural Disasters	
15. Seismic data (Mining Projects)- zone no, no of earthquakes and scale, impacts on life, property existing mines	<ul style="list-style-type: none"> ⊗ Indian Meteorology Department, Pune ⊗ Geological Survey of India
16. Landslide prone zone, geomorphological conditions, degree of susceptibility to mass movement, major landslide history (frequency of occurrence/decade), area affected, population affected	<ul style="list-style-type: none"> ⊗ Space Application Centre
17. Flood/cyclone/droughts- frequency of occurrence per decade, area affected, population affected	<ul style="list-style-type: none"> ⊗ Natural Disaster Management Division in Department of Agriculture and Cooperation ⊗ Indian Meteorological Department
Industrial	
18. Industrial Estates/Clusters, Growth Centres	<ul style="list-style-type: none"> ⊗ State Industrial Corporation ⊗ Industrial Associations ⊗ State Pollution Control Boards ⊗ Confederation Indian Industries (CII) ⊗ FICCI
19. Physical and Chemical properties of raw material and chemicals (Industrial projects); fuel quality	<ul style="list-style-type: none"> ⊗ Material and Safety Data Sheets ⊗ ENVIS database of Industrial Toxicological Research Centre, Lucknow ⊗ Indian Institute Petroleum
20. Occupational Health and Industrial Hygiene- major occupational health and safety hazards, health and safety requirements, accident histories	<ul style="list-style-type: none"> ⊗ Central Labour Institute, Mumbai ⊗ Directorate of Industrial Safety ⊗ ENVIS Database of Industrial Toxicological Research Centre, Lucknow ⊗ National Institute of Occupational Health, Ahmedabad
21. Pollutant release inventories (Existing pollution sources in area within 10 km radius)	<ul style="list-style-type: none"> ⊗ Project proponents which have received EC and have commenced operations
22. Water requirement (process, cooling water, DM water, Dust suppression, drinking, green belt, fire service)	<ul style="list-style-type: none"> ⊗ EIA Reports ⊗ National and International Benchmarks

Annexure VIIIB: Summary of Available Data with Potential Data Sources for EIA

Agency	Information Available
1. Archaeological Survey of India Department of Culture Government of India Janpath, New Delhi - 110011 Asi@del3.vsnl.net.in	<ul style="list-style-type: none"> ⊙ Inventory of monuments and sites of national importance- Listing and documentation of monuments according to world heritage, pre historic, proto historic and secular, religious places and forts
2. Botanical Survey Of India P-8, Brabourne Road Calcutta 700001 Tel#033 2424922 Fax#033 2429330 Email: envis@cal2.vsnl.net.in . RO - Coimbatore, Pune, Jodhpur, Dehradun, Allahabad, Gantok, Itanagar, Port Blair	<ul style="list-style-type: none"> ⊙ Photodiversity documentation of flora at National, State and District level and flora of protected areas, hotspots, fragile ecosystems, sacred groves etc ⊙ Identification of threatened species including endemics, their mapping, population studies ⊙ Database related to medicinal plants, rare and threatened plant species ⊙ Red data book of Indian plants (Vol 1,2, and 3) ⊙ Manual for roadside and avenue plantation in India
3. Bureau of Indian Standards Manak Bhawan, 9 Bahadur Shah Zafar Marg, New Delhi 110 002 Tel#3230131, 3233375, 3239402 (10 lines) Fax : 91 11 3234062, 3239399, 3239382 Email- bis@vsnl.com	<ul style="list-style-type: none"> ⊙ Bureau of Indian Standards Committees on Earthquake Engineering and Wind Engineering have a Seismic Zoning Map and the Wind Velocity Map including cyclonic winds for the country
4. Central Water Commission (CWC) Sewa Bhawan, R.K.Puram New Delhi - 110066 cmanoff@niccwc.delhi.nic.in RO- Bangalore, Bhopal, Bhubaneshwar, Chandigarh, Coimbatore/Chennai, Delhi, Hyderabad, Lucknow, Nagpur, Patna, Shillong, Siliguri and Vadodara	<ul style="list-style-type: none"> ⊙ Central Data Bank -Collection, collation and Publishing of Hydrological, Hydrometeorological, Sediment and Water Quality data- ⊙ Basin wise Master Plans ⊙ Flood atlas for India ⊙ Flood Management and Development and Operation of Flood Forecasting System- CWC operate a network of forecasting stations Over 6000 forecasts are issued every year with about 95% of the forecasts within the permissible limit. ⊙ Water Year Books, Sediment Year Books and Water Quality Year Books. ⊙ Also actively involved in monitoring of 84 identified projects through National, State and Project level Environmental Committees for ensuring implementation of environmental safeguards
5. Central Ground Water Board (HO) N.H.IV, New CGO Complex, Faridabad - 121001 RO - Guwahati, Chandigarh, Ahemadabad, Trivandrum, Calcutta, Bhopal, Lucknow, Banglore, Nagpur, Jammu, Bhubneshwar, Raipur, Jaipur, Chennai, Hyderabad, Patna	<ul style="list-style-type: none"> ⊙ surveys, exploration, monitoring of ground water development

¹⁶ Based on web search and literature review

6.	Central Pollution Control Board Parivesh Bhawan, CBD-cum-Office Complex East Arjun Nagar, DELHI - 110 032 INDIA E-mail : cpcb@alpha.nic.in	<ul style="list-style-type: none"> ⊗ National Air Quality Monitoring Programme ⊗ National River Water Quality Monitoring Programme- Global Environment Monitoring , MINARS ⊗ Zoning Atlas Programme ⊗ Information on 17 polluting category industries (inventory, category wise distribution, compliance, implementation of pollution control programmes)
7.	Central Arid Zone Research Institute, Jodhpur Email : cazri@x400.nicgw.nic.in Regional Centre at Bhuj in Gujarat	<ul style="list-style-type: none"> ⊗ AGRIS database on all aspects of agriculture from 1975 to date ⊗ Also have cell on Agriculture Research Information System; ⊗ Working on ENVIS project on desertification ⊗ Repository of information on the state of natural resources and desertification processes and their control ⊗ The spectrum of activities involves researches on basic resource inventories; monitoring of desertification, rehabilitation and management of degraded lands and other areas
8.	Central Inland Capture Fisheries Research Institute, Barrackpore- 743101, Tel#033-5600177 Fax#033-5600388 Email : cicfri@x400.nicgw.nic.in	<ul style="list-style-type: none"> ⊗ Data Base on Ecology and fisheries of major river systems of India. Biological features of commercially important riverine and estuarine fish species. Production functions and their interactions in floodplain wetlands. ⊗ Activities - Environmental Impact Assessment for Resource Management ; Fisheries Resource surveys
9.	Central Institute of Brackish Water Aquaculture 141, Marshalls Road, Egmore , Chennai - 600 008, Tel# 044-8554866, 8554891, Director (Per) 8554851 Fax#8554851,	<ul style="list-style-type: none"> ⊗ Repository of information on brackish water fishery resources with systematic database of coastal fishery resources for ARIS ⊗ Agricultural Research Information System (ARIS) database covers State wise data on soil and water quality parameters, land use pattern, production and productivity trends, ⊗ Social, economic and environmental impacts of aquaculture farming, ⊗ Guidelines and effluent standards for aquaculture farming
10.	Central Marine Fisheries Research Institute (CMFRI), Cochin	<ul style="list-style-type: none"> ⊗ Assessing and monitoring of exploited and un-exploited fish stocks in Indian EEZ ⊗ Monitoring the health of the coastal ecosystems, particularly the endangered ecosystems in relation to artisanal fishing, mechanised fishing and marine pollution ⊗ The institute has been collecting data on the catch and effort and biological characteristics for nearly half a century based on scientifically developed sampling scheme, covering all the maritime States of the country ⊗ The voluminous data available with the institute is managed by the National Marine Living Resources Data Centre (NMLRDC)
11.	Central Water and Power Research Station, Pune Tel#020-4391801-14; 4392511; 4392825 Fax #020-4392004,4390189	<ul style="list-style-type: none"> ⊗ Numerical and Physical models for hydro-dynamic simulations
12.	Central Institute of Road Transport, Bhosari, Pune 411 026, India. Tel : +91 (20) 7125177, 7125292, 7125493, 7125494	<ul style="list-style-type: none"> ⊗ Repository of data on all aspects of performance of STUs and a host of other related road transport parameters

13. Department of Ocean Development	<ul style="list-style-type: none"> ⑨ Assessment of environment parameters and marine living resources (primary and secondary) in Indian EEZ (Nodal Agency NIO Kochi) ⑨ Stock assessment, biology and resource mapping of deep sea shrimps, lobsters and fishes in Indian EEZ (Nodal agency-Fisheries Survey of India) ⑨ Investigations of toxical algal blooms and benthic productivity in Indian EEZ (Nodal agency- Cochin University of Science and technology) ⑨ Coastal Ocean Monitoring and Prediction System (COMAP) - monitoring and modelling of marine pollution along entire Indian coast and islands. Parameters monitored are temp, salinity, DO, pH, SS, BOD, inorganic phosphate, nitrate, nitrite, ammonia, total phosphorus, total nitrite, total organic carbon, petroleum hydrocarbons, pathogenic vibrios, pathogenic E.coli, shigella, salmonella, heavy metals (Cd, Hg, Pb) and pesticide residues (DDT, BHC, Endosulfan). Monitoring is carried out along the ecologically sensitive zones and urban areas (NIO Mumbai- Apex coordinating agency). ⑨ Sea Level Measurement Programme (SELMAM)- sea level measurement at selected stations (Porbandar, Bombay, Goa, Cochin, Tuticorin, Madras, Machilipatnam, Visakhapatnam, Paradeep, Calcutta and Kavaratti (Lakshadweep Island)) along Indian coast and islands using modern tide gauges ⑨ Detailed coastal maps through Survey of India showing contour at 1/2 a metre interval in the scale of 1:25000. (Nellore- Machhalipatnam work already over) ⑨ Marine Data Centre (MDC) IMD for Ocean surface meteorology, GSI for marine geology, SOI for tide levels, Naval Hydrographic Office for bathymetry, NIO Goa for physical chemical and biological oceanography, NIO Mumbai for marine pollution, CMFRI for coastal fisheries, Institute of Ocean Management Madras for coastal geomorphology ⑨ DOD has setup Indian National Centre for Ocean Information Services (INCOIS) at Hyderabad for generation and dissemination of ocean data products (near real time data products such as sea surface temperature, potential fishing zones, upwelling zones, maps, eddies, chlorophyll, suspended sediment load etc). MDC will be integrated with INCOIS ⑨ Integrated Coastal and Marine Area Management (ICMAM) programme - GIS based information system for management of 11 critical habitats namely Pichavaram, Karwar, Gulf of Mannar, Gulf of Khambat, Gulf of Kutch, Malvan, Cochin, Coringa mangroves, Gahirmata, Sunderbans and Kadamat (Lakshadweep) ⑨ Wetland maps for Tamil Nadu and Kerala showing the locations of lagoons, backwaters, estuaries, mudflats etc (1:50000 scale) ⑨ Coral Reef Maps for Gulf of Kachch, Gulf of Mannar, Andaman and Nicobar and Lakshadweep Islands (1:50,000 scale) indicating the condition of corals, density etc
14. Environment Protection Training and Research Institute Gachibowli, Hyderabad - 500 019, India Phone: +91-40-3001241, 3001242, 3000489 Fax: +91-40- 3000361 E-mail: info@eptri.com	<ul style="list-style-type: none"> ⑨ Environment Information Centre- has appointed EPTRI as the Distributed Information Centre for the Eastern Ghats region of India. EIC Collaborates with the Stockholm Environment Institute Sweden Database on Economics of Industrial Pollution Prevention in India Database of Large and Medium Scale Industries of Andhra Pradesh Environmental Status of the Hyderabad Urban Agglomeration Study on 'water pollution-health linkages' for a few Districts of A.P

		<ul style="list-style-type: none"> ⑨ Environment Quality Mapping <ul style="list-style-type: none"> Macro level studies for six districts in the State of Andhra Pradesh Micro level studies for two study zones presenting the permissible pollutant load and scoping for new industrial categories Zonation of the IDA, Parwada which helped APIIC to promote the land for industrial development Disaster management plan for Visakhapatnam Industrial Bowl Area
15.	<p>Forest Survey of India (FSI) Kaulagarh Road, P.O., IPE Dehradun - 248 195 Tel# 0135-756139, 755037, 754507 Fax # 91-135-759104 E-Mail : fsidir@nde.vsnl.net.in fsihq@nde.vsnl.net.in</p> <p>RO- Banglore, Calcutta, Nagpur and Shimla</p>	<ul style="list-style-type: none"> ⑨ State of Forest Report (Biannual) ⑨ National Forest Vegetation Map (Biannual exercise) (on 1: 1 million scale) ⑨ Thematic mapping on 1:50,000 scale depicting the forest type, species composition, crown density of forest cover and other landuse National ⑨ Basic Forest Inventory System ⑨ Inventory survey of non forest area ⑨ Forest inventory report providing details of area estimates, topographic description, health of forest, ownership pattern, estimation of volume and other growth parameters such as height and diameter in different types of forest, estimation of growth, regeneration and mortality of important species, volume equation and wood consumption of the area studied
16.	<p>Geological Survey of India 27 Jawaharlal Nehru Road, Calcutta 700 016, India Telephone +91-33- 2496941 FAX 91-33-2496956 gsi_chq@vsnl.com</p>	<ul style="list-style-type: none"> ⑨ Environmental hazards zonation mapping in mineral sector ⑨ Codification of base line information of geo-environmental appreciation of any terrain and related EIA and EMP studies ⑨ Lineament and geomorphological map of India on 1:20,000 scale. ⑨ Photo-interpreted geological and structural maps of terrains with limited field checks.
17.	<p>Indian Council of Agriculture Research, Krishi Bhawan, New Delhi, Tel#011-338206</p> <ul style="list-style-type: none"> - ICAR complex, Goa- Agro metrology - Central Arid Zone Research Institute- Agro forestry - Central Soil salinity Research Institute, - Indian Institute of Soil Science - Central Soil and Water Conservation Research and Training Institute - National Bureau of Soil Survey and Landuse Planning 	<ul style="list-style-type: none"> ⑨ A total of 80,000 profiles at 10 kms grid across the country were analyzed to characterize the soils of India. ⑨ Detailed soil maps of the Country (1:7 million), State (1:250,000) and districts map (1:50,000) depicting extent of degradation (1:4.4 millions) have been prepared. ⑨ Thematic maps depicting soil depth, texture drainage, calcareousness, salinity, pH, slope and erosion have been published ⑨ Agro-climate characterization of the country based on moisture, thermal and sunshine regimes ⑨ Agro-ecological zones (20) and sub-zones (60) for the country were delineated based on physiography, soils, climate, Length of Growing Period and Available Water Content, and mapped on 1:4.4 million scale. ⑨ Digitization of physiography and soil resource base on 1:50,000 scale for 14 States have been completed. ⑨ .Soil fertility maps of N,P,K,S and Zn have also been developed ⑨ Water quality guidelines for irrigation and naturally occurring saline/sodic water ⑨ Calibration and verification of ground water models for predicting water logging and salinity hazards in irrigation commands
18.	<p>Indian Bureau of Mines Indira Bhawan, Civil Lines Nagpur Ph no - 0712-533 631, Fax- 0712-533 041</p>	<ul style="list-style-type: none"> ⑨ National mineral inventory for 61 minerals and mineral maps ⑨ Studies on environmental protection and pollution control in regard to the mining and mineral beneficiation operations ⑨ Collection, processing and storage of data on mines, minerals and mineral-based industries, collection and maintenance of world mineral intelligence, foreign mineral legislation and other related matters

19.	Indian Meteorology Department Shivaji nagar, Pune 41100 RO- Mumbai, Chennai, Calcutta, New Delhi, Nagpur, Guwahati	<ul style="list-style-type: none"> ⊙ Meteorological data ⊙ Background air quality monitoring network under Global Atmospheric Watch Programme (operates 10 stations) ⊙ Seismicity map, seismic zoning map; seismic occurrences and cyclone hazard monitoring; list of major earthquakes ⊙ Climatological Atlas of India , Rainfall Atlas of India and Agroclimatic Atlas of India ⊙ Monthly bulletin of Climate Diagnostic Bulletin of India ⊙ Environmental Meteorological Unit of IMD at Delhi to provide specific services to MoEF
20.	INTACH Natural Heritage, 71 Lodi Estate, New Delhi-110 003 Tel. 91-11-4645482, 4632267/9, 4631818, 4692774, 4641304 Fax : 91- 11-4611290 E-mail : nh@intach.net	<ul style="list-style-type: none"> ⊙ Listing and documentation of heritage sites identified by municipalities and local bodies (Listing excludes sites and buildings under the purview of the Archaeological Survey of India and the State Departments of Archaeology)
21.	Industrial Toxicology Research Centre Post Box No. 80, Mahatma Gandhi Marg, Lucknow-226001, Phone: +91-522- 221856,213618,228227; Fax : +91- 522 228227 Email: itrc@itrcindia.org	<ul style="list-style-type: none"> ⊙ Activities include health survey on occupational diseases in industrial workers, air and water quality monitoring studies, ecotoxicological impact assessment, toxicity of chemicals, human health risk assessment ⊙ Five databases on CD-ROM in the area of environmental toxicology viz: TOXLINE, CHEMBANK, POISINDEX, POLTOX and PESTBANK. The Toxicology Information Centre provides information on toxic chemicals including household chemicals ⊙ ENVIS centre and created a full-fledged computerized database (DABTOC) on toxicity profiles of about 450 chemicals
22.	Indian Institute of Forest Management Post Box No. 357, Nehru Nagar Bhopal - 462 003 Phone # 0755-575716, 573799, 765125, 767851 Fax # 0755-572878	<ul style="list-style-type: none"> ⊙ Consultancy and research on joint forest management (Ford Foundation, SIDA, GTZ, FAO etc)
23.	Indian Institute of Petroleum Mohkampur , Dehradun, India, 248005 0135- 660113 to 116 0135- 671986	<ul style="list-style-type: none"> ⊙ Fuel quality characterisation ⊙ Emission factors
24.	Ministry of Environment and Forest	<ul style="list-style-type: none"> ⊙ Survey of natural resources ⊙ National river conservation directorate ⊙ Environmental research programme for eastern and western ghats ⊙ National natural resource management system ⊙ Wetlands conservation programme- survey, demarcation, mapping landscape planning, hydrology for 20 identified wetlands National wasteland identification programme
25.	Mumbai Metropolitan Regional Development Authority	<ul style="list-style-type: none"> ⊙ Mumbai Urban Transport Project ⊙ Mumbai Urban Development Project ⊙ Mumbai Urban Rehabilitation Project ⊙ Information on MMR; statistics on councils and corporations Regional Information Centre- Basic data on population, employment, industries and other sectors are regularly collected and processed

26.	Municipal Corporation of Greater Mumbai	<ul style="list-style-type: none"> ⊙ Air Quality Data for Mumbai Municipal Area ⊙ Water quality of lakes used for water supply to Mumbai
27.	Ministry of Urban Development Disaster Mitigation and Vulnerability Atlas of India Building Materials & Technology Promotion Council G-Wing, Nirman Bhavan, New Delhi-110011 Tel: 91-11-3019367 Fax: 91-11-3010145 E-Mail: bmtpc@del2.vsnl.net.in	<ul style="list-style-type: none"> ⊙ Identification of hazard prone area ⊙ Vulnerability Atlas showing areas vulnerable to natural disasters ⊙ Land-use zoning and design guidelines for improving hazard resistant construction of buildings and housing ⊙ State wise hazard maps (on cyclone, floods and earthquakes)
28.	Natural Disaster Management Division in Department of Agriculture and Cooperation	<ul style="list-style-type: none"> ⊙ Weekly situation reports on recent disasters, reports on droughts, floods, cyclones and earthquakes
29.	National Bureau Of Soil Survey & Land Use Planning P.O. Box No. 426, Shankar Nagar P.O., Nagpur-440010 Tel#91-712-534664,532438,534545 Fax#:91-712-522534 RO- Nagpur, New Delhi, Bangalore, Calcutta, Jorhat, Udaipur	<ul style="list-style-type: none"> ⊙ NBSS&LUP Library has been identified as sub centre of ARIC (ICAR) for input to AGRIS covering soil science literature generated in India ⊙ Research in weathering and soil formation, soil morphology, soil mineralogy, physicochemical characterisation, pedogenesis, and landscape-climate-soil relationship. ⊙ Soil Series of India- The soils are classified as per Soil Taxonomy. The described soil series now belong to 17 States of the country. ⊙ Landuse planning- watershed management, land evaluation criteria, crop efficiency zoning ⊙ Soil Information system is developed state-wise at 1:250,000 scale. Presently the soil maps of all the States are digitized, processed and designed for final output both digital and hardcopy. The thematic layers and interpreted layers of land evaluation (land capability, land irrigability and crop suitability), Agro-Ecological Zones and soil degradation themes are prepared. ⊙ Districts level information system is developed for about 15 districts at 1:50,000 scale. The soil information will be at soil series level in this system. Soil resource inventory of States, districts water-sheds (1:250,000; 1:50,000; 1:10,000/8000)
30.	National Institute of Ocean Technology, Velacherry-Tambaram main road Narayanapuram Chennai, Tamil Nadu Tel#91-44-2460063 / 2460064/ 2460066/ 2460067 Fax#91-44-2460645	<ul style="list-style-type: none"> ⊙ Waste load allocation in selected estuaries (Tapi estuary and Ennore creek) is one the components under the Integrated Coastal and Marine Area Management (ICMAM) programme of the Department of Ocean Development ICMAM is conducted with an IDA based credit to the Government of India under the Environmental Capacity Building project of MoEF (waste assimilation capacity of Ennore creek is over) ⊙ Physical oceanographic component of Coastal & Ocean monitoring Predictive System (COMAPS) a long term monitoring program under the Department of Ocean Development ⊙ Identification of suitable locations for disposal of dredge spoil using mathematical models & environmental criteria ⊙ EIA Manual and EIA guidelines for port and harbour projects
31.	National Institute of Oceanography, Goa RO- Mumbai, Kochi	<ul style="list-style-type: none"> ⊙ Coastal Ocean Monitoring and Predictions(COMAP)-Monitoring of coastal waters for physicochemical and biological parameters including petroleum hydrocarbons, trace metals, heavy metals, and biomass of primary (phytoplankton) and secondary (zooplankton, microbial and benthic organisms) ⊙ Marine Biodiversity of selected ecosystem along the West Coast of India

32.	National Botanical Research Institute, Post Box No 436 Rana Pratap Marg Lucknow- 226001, Tel: (+91) 522 271031-35 Fax: (+91) 522 282849, 282881 Lucknow	<ul style="list-style-type: none"> ⊗ Dust filtering potential of common avenue trees and roadside shrubs has been determined, besides studies have also been conducted on heavy-metals accumulation potential of aquatic plants supposedly useful as indicators of heavy metal pollution in water bodies and capable of reducing the toxic metals from water bodies. ⊗ Assessment of bio-diversity of various regions of India
33.	National Geophysical Research Institute, Uppal Road, Hyderabad Telephone:0091-40-7171124, FAX:0091-40-7171564	<ul style="list-style-type: none"> ⊗ Exploration, assessment and management of ground water resources including ground water modelling and pollution studies
34.	National Environmental Engineering Research Institute, Nagpur RO- Mumbai, Delhi, Chennai, Calcutta, Ahmedabad, Cochin, Hyderabad, Kanpur	<ul style="list-style-type: none"> ⊗ National Air Quality Monitoring (NAQM) for CPCB ⊗ Database on cleaner technologies of industrial productions
35.	National Hydrology Institute, Roorkee RO- Belgaum (Hard Rock Regional Centre), Jammu (Western Himalayan Regional Centre), Guwahati (North Eastern Regional Centre), Kakinada (Deltaic Regional Centre), Patna (Ganga Plains North Regional Centre), and Sagar (Ganga Plains South)	<ul style="list-style-type: none"> ⊗ Basin studies, hydrometeorological network improvement, hydrological year book, hydrological modelling, regional flood formulae, reservoir sedimentation studies, environmental hydrology, watershed development studies, tank studies, and drought studies.
36.	National Institute Of Urban Affairs, India Habitat Centre, New Delhi	<ul style="list-style-type: none"> ⊗ Urban Statistics Handbook
37.	National Institute of Occupational Health Meghaninagar, Ahmedabad RO- Banglore, Calcutta	<ul style="list-style-type: none"> ⊗ epidemiological studies and surveillance of hazardous occupations including air pollution, noise pollution, agricultural hazards, industrial hazards in organised sectors as well as small scale industries, carcinogenesis, pesticide toxicology, etc ⊗ WHO collaborative centre for occupational health for South East Asia region and the lead institute for the international programme on chemical safety under IPCS (WHO)
38.	NRSA Data Centre Department of Space, Balanagar, Hyderabad 500 037 Ph- 040-3078560 3078664 sales@nrsa.gov.in	<ul style="list-style-type: none"> ⊗ Satellite data products (raw data, partially processed (radiometrically corrected but geometrically uncorrected), standard data (radiometrically and geometrically corrected), geocoded data(1:50,000 and 1:25000 scale), special data products like mosaiced, merged and extracted) available on photographic (B&W and FCC in form of film of 240 mm X 240mm or enlargements/paper prints in scale varying between 1:1M and 1:12500 and size varying between 240mm and 1000mm) and digital media (CD-ROMs, 8 mm tapes)
39.	Rajiv Gandhi National Drinking Water Mission	<ul style="list-style-type: none"> ⊗ Database for groundwater using remote sensing technology (Regional Remote Sensing Service Centre involved in generation of ground water prospect maps at 1:50,000 scale for the State of Kerala, Karnataka, AP, MP and Rajasthan for RGNDWM)
40.	Space Application Centre Value Added Services Cell (VASC) Remote Sensing Application Area Ahmedabad 380 053 079-676 1188	<ul style="list-style-type: none"> ⊗ National Natural Resource Information System ⊗ Landuse mapping for coastal regulation zone (construction setback line) upto 1:12500 scale ⊗ Inventory of coastal wetlands, coral reefs, mangroves, seaweeds ⊗ Monitoring and condition assessment of protected coastal areas

	Fax- 079-6762735	<ul style="list-style-type: none"> ⊗ Wetland mapping and inventory ⊗ Mapping of potential hotspots and zoning of environmental hazards ⊗ General geological and geomorphological mapping in diverse terrain ⊗ Landslide risk zonation for Tehre area
41.	State Pollution Control Board	<ul style="list-style-type: none"> ⊗ State Air Quality Monitoring Programme ⊗ Inventory of polluting industries ⊗ Identification and authorization of hazardous waste generating industries ⊗ Inventory of biomedical waste generating industries ⊗ Water quality monitoring of water bodies receiving wastewater discharges ⊗ Inventory of air polluting industries ⊗ Industrial air pollution monitoring ⊗ Air consent, water consent, authorization, environment monitoring reports
42.	State Ground Water Board	
43.	Survey of India	<ul style="list-style-type: none"> ⊗ Topographical surveys on 1:250,000 scales, 1:50,000 and 1:25,000 scales ⊗ Digital Cartographical Data Base of topographical maps on scales 1:250,000 and 1:50,000 ⊗ Data generation and its processing for redefinition of Indian Geodetic Datum ⊗ Maintenance of National Tidal Data Centre and receiving/ processing of tidal data of various ports. ⊗ Coastal mapping along the Eastern coast line has been in progress to study the effect of submergence due to rise in sea-level and other natural phenomenon. Ground surveys have been completed for the proposed coastal region and maps are under printing. ⊗ District planning maps containing thematic information (135 maps) have been printed out of 249 maps covering half the districts of India. Districts planning maps for remaining half of the area are being processed by National Atlas and Thematic Mapping Organisation (NATMO)
44.	Town and Country Planning Organisation	<ul style="list-style-type: none"> ⊗ Urban mapping - Thematic maps and graphic database on towns (under progress in association with NRSA and State town planning department)
45.	Wildlife Institute of India Post Bag No. 18, Chandrabani Dehradun - 248 001, Uttaranchal Tel#0135 640111 -15, Fax#0135 640117 email : wii@wii .	<ul style="list-style-type: none"> ⊗ Provide information and advice on specific wildlife management problems. ⊗ National Wildlife Database
46.	Zoological Survey of India Prani Vigyan Bhawan 'M' Block, New Alipore Calcutta - 700 053 Phone # 91-33-4786893, 4783383 Fax # 91-33-786893 RO - Shillong, Pune, Dehradun, Jabalpur, Jodhpur, Chennai, Patna, Hyderabad, Canning, Behrampur, Kozikode, Itanagar, Digha, Port Blair, Solan	<ul style="list-style-type: none"> ⊗ Red Book for listing of endemic species ⊗ Survey of faunal resources

ANNEXURE IX
Impact Prediction Tools

Table 1: Choice of Models for Impact Prediction: Air Environment*

Model	Application	Remarks
ISCST 3	<ul style="list-style-type: none"> ▪ Appropriate for point, area and line sources ▪ Application for flat or rolling terrain ▪ Transport distance up to 50 km valid ▪ Computes for 1 hr to annual averaging periods 	<ul style="list-style-type: none"> ▪ Can take up to 99 sources ▪ Computes concentration on 600 receptors in Cartesian on polar coordinate system ▪ Can take receptor elevation ▪ Requires source data, meteorological and receptor data as input.
AERMOD with AERMET	<ul style="list-style-type: none"> ▪ Settling and dry deposition of particles; ▪ Building wake effects (excluding cavity region impacts); ▪ Point, area, line, and volume sources; ▪ Plume rise as a function of downwind distance; ▪ Multiple point, area, line, or volume sources; ▪ Limited terrain adjustment; ▪ Long-term and short-term averaging modes; ▪ Rural or urban modes; ▪ Variable receptor grid density; ▪ Actual hourly meteorology data 	<ul style="list-style-type: none"> ▪ Can take up to 99 sources ▪ Computes concentration on 600 receptors in Cartesian on polar coordinate system ▪ Can take receptor elevation ▪ Requires source data, meteorological and receptor data as input.
PTMAX	<ul style="list-style-type: none"> ▪ Screening model applicable for a single point source ▪ Computes maximum concentration and distance of maximum concentration occurrence as a function of wind speed and stability class 	<ul style="list-style-type: none"> ▪ Require source characteristics ▪ No met data required ▪ Used mainly for ambient air monitoring network design
PTDIS	<ul style="list-style-type: none"> ▪ Screening model applicable for a single point source ▪ Computes maximum pollutant concentration and its occurrences for the prevailing meteorological conditions 	<ul style="list-style-type: none"> ▪ Require source characteristics ▪ Average met data (wind speed, temperature, stability class <i>etc.</i>) required ▪ Used mainly to see likely impact of a single source
MPTER	<ul style="list-style-type: none"> ▪ Appropriate for point, area and line sources applicable for flat or rolling terrain ▪ Transport distance up to 50 km valid ▪ Computes for 1 hr to annual averaging periods ▪ Terrain adjustment is possible 	<ul style="list-style-type: none"> ▪ Can take 250 sources ▪ Computes concentration at 180 receptors up to 10 km ▪ Requires source data, meteorological data and receptor coordinates
CTDM PLUS (Complex Terrain Dispersion Model)	<ul style="list-style-type: none"> ▪ Point source steady state model, can estimate hrly average concentration in isolated hills/ array of hills 	<ul style="list-style-type: none"> ▪ Can take maximum 40 Stacks and computes concentration at maximum 400 receptors ▪ Does not simulate calm met conditions ▪ Hill slopes are assumed not to exceed 15 degrees ▪ Requires sources, met and terrain characteristics and receptor details

Model	Application	Remarks
UAM (Urban Airshed Model)	<ul style="list-style-type: none"> ▪ 3-D grid type numerical simulation model ▪ Computes O₃ concentration short term episodic conditions lasting for 1 or 2 days resulting from NO_x and VOCs ▪ Appropriate for single urban area having significant O₃ problems 	<ul style="list-style-type: none"> ▪
RAM (Rural Airshed Model)	<ul style="list-style-type: none"> ▪ Steady state Gaussian plume model for computing concentration of relatively stable pollutants for 1 hr to 1 day averaging time ▪ Application for point and area sources in rural and urban setting 	<ul style="list-style-type: none"> ▪ Suitable for flat terrains ▪ Transport distance less than 50 km.
CRESTER	<ul style="list-style-type: none"> ▪ Applicable for single point source either in rural or urban setting ▪ Computes highest and second highest concentration for 1hr, 3hr, 24hr and annual averaging times ▪ Tabulates 50 highest concentration for entire year for each averaging times 	<ul style="list-style-type: none"> ▪ Can take up to 19 Stacks simultaneously at a common site. ▪ Unsuitable for cool and high velocity emissions ▪ Do not account for tall buildings or topographic features ▪ Computes concentration at 180 receptor, circular wing at five downwind ring distance 36 radials ▪ Require sources, and met data
OCD (Offshore and coastal Dispersion Model)	<ul style="list-style-type: none"> ▪ It determines the impact of offshore emissions from point sources on the air quality of coastal regions ▪ It incorporates overwater plume transport and dispersion as well as changes that occur as the plume crosses the shore line ▪ Most suitable for overwater sources shore onshore receptors are below the lowest shore height 	<ul style="list-style-type: none"> ▪ Requires source emission data ▪ Require hrly met data at offshore and onshore locations like water surface temperature; overwater air temperature; relative humidity <i>etc.</i>
FDM (Fugitive Dust Model)	<ul style="list-style-type: none"> ▪ Suitable for emissions from fugitive dust sources ▪ Source may be point, area or line (up to 121 source) ▪ Require particle size classification max. up to 20 sizes ▪ Computes concentrations for 1 hr, 3hr, 8hr, 24hr or annual average periods 	<ul style="list-style-type: none"> ▪ Require dust source particle sizes ▪ Source coordinates for area sources, source height and geographic details ▪ Can compute concentration at max. 1200 receptors ▪ Require met data (wind direction, speed, Temperature, mixing height and stability class) ▪ Model do not include buoyant point sources, hence no plume rise algorithm
RTDM (Rough Terrain Diffusion Model)	<ul style="list-style-type: none"> ▪ Estimates GLC is complex/rough (or flat) terrain in the vicinity of one or more co-located point sources ▪ Transport distance max. up to 15 km to up to 50 km ▪ Computes for 1 to 24 hr. or annual average concentrations 	<ul style="list-style-type: none"> ▪ Can take up to 35 co-located point sources ▪ Require source data and hourly met data ▪ Computes concentration at maximum 400 receptors ▪ Suitable only for non reactive gases ▪ Do not include gravitational

Model	Application	Remarks
		effects or depletion mechanism such as rain/ wash out, dry deposition
CDM(Climatologically Dispersion Model)	<ul style="list-style-type: none"> ▪ It is a climatologically steady state GPM for determining long term (seasonal or annual) ▪ Arithmetic average pollutant concentration at any ground level receptor in an urban area 	<ul style="list-style-type: none"> ▪ Suitable for point and area sources in urban region, flat terrain ▪ Valid for transport distance less than 50 km ▪ Long term averages: One month to one year or longer
PLUVUE-II (Plume Visibility Model)	<ul style="list-style-type: none"> ▪ Applicable to assess visibility impairment due to pollutants emitted from well defined point sources ▪ It is used to calculate visual range reduction and atmospheric discoloration caused by plumes ▪ It predicts transport, atmospheric diffusion, chemical, conversion, optical effects, and surface deposition of point source emissions. 	<ul style="list-style-type: none"> ▪ Require source characteristics, met data and receptor coordinates & elevation ▪ Require atmospheric aerosols (back ground & emitted) characteristics, like density, particle size ▪ Require background pollutant concentration of SO₄, NO₃, NO_x, NO₂, O₃, SO₂ and deposition velocities of SO₂, NO₂ and aerosols
MESO-PUFF II (Meso scale Puff Model)	<ul style="list-style-type: none"> ▪ It is a Gaussian, Variable trajectory, puff superposition model designed to account for spatial and temporal variations in transport, diffusion, chemical transformation and removal mechanism encountered on regional scale. ▪ Plume is modeled as a series of discrete puffs and each puff is transported independently ▪ Appropriate for point and area sources in urban areas ▪ Regional scale model. 	<ul style="list-style-type: none"> ▪ Can model five pollutants simultaneously (SO₂, SO₄, NO_x, HNO₃ and NO₃) ▪ Require source characteristics ▪ Can take 20 point sources or 5 area source ▪ For area source – location, effective height, initial puff size, emission is required ▪ Computes pollutant concentration at max. 180 discrete receptors and 1600 (40 x 40) grided receptors ▪ Require hourly surface data including cloud cover and twice a day upper air data (pressure, temp, height, wind speed, direction) ▪ Do not include gravitational effects or depletion mechanism such as rain/ wash out, dry deposition

Table 2: Choice of Models for Impact Modeling: Noise Environment*

Model	Application
FHWA (Federal Highway Administration)	Noise Impact due to vehicular movement on highways
Dhwani	For predictions of impact due to group of noise sources in the industrial complex (multiple sound sources)
Hemispherical sound wave propagation Air Port	Fore predictive impact due to single noise source For predictive impact of traffic on airport and rail road

Table 3: Choice of Models for Impact Modeling: Land Environment*

Model	Application	Remarks
Digital Analysis Techniques	Provides land use / land cover distribution	
Ranking analysis for soil suitability criteria	Provides suitability criteria for developmental conversation activities	Various parameters viz. depth, texture, slope, erosion status, geomorphology, flooding hazards, GW potential, land use <i>etc.</i> , are used.

Table 4: Choice of Models for Impact Modeling: Water Environment*

Model	Application	Remarks
QUAL-II E	Wind effect is insignificant, vertical dispersive effects insignificant applicable to streams Data required Deoxygenation coefficients, re-aeration coefficients for carbonaceous, nitrogenous and benthic substances, dissolved oxygen deficit	Steady state or dynamic model
	The model is found excellent to generate water quality parameters Photosynthetic and respiration rate of suspended and attached algae	
	Parameters measured up to 15 component can be simulated in any combination, e.g. ammonia, nitrite, nitrate, phosphorous, carbonaceous BOD, benthic oxygen demand, DO, coliforms, conservative substances and temperature	
DOSAG-3, USEPA: (1-D) RECEIV – II, USEPA	Water quality simulation model for streams & canal A general Water quality model	Steady-state
Explore –I, USEPA	A river basin water quality model	Dynamic, Simple hydrodynamics

Model	Application	Remarks
HSPE, USEPA	Hydrologic simulation model	Dynamic, Simple hydrodynamics
RECEIVE-II, USEPA	A general dynamic planning model for water quality management	
Stanford watershed model	This model simulates stream flows once historic precipitation data are supplied The major components of the hydrologic cycle are modeled including interception, surface detention, overland inflow, groundwater, evapo-transpiration and routing of channel flows, temperature, TDS, DO, carbonaceous BOD coliforms, algae, zooplanktons, nitrite, nitrate, ammonia, phosphate and conservative substances can be simulated	
Hydrocomp model	Long-term meteorological and wastewater characterization data is used to simulate stream flows and stream water quality	Time dependant (Dynamic)
Stormwater Management model (SWMM)	Runoff is modeled from overland flow, through surface channels, and through sewer network Both combined and separate sewers can be modeled. This model also enables to simulate water quality effects to stormwater or combined sewer discharges. This model simulates runoff resulting from individual rainfall events.	Time Dependent
Battelle Reservoir model	Water body is divided into segments along the direction of the flow and each segment is divided into number of horizontal layers. The model is found to generate excellent simulation of temperature and good prediction of water quality parameters. The model simulates temperature, DO, total and benthic BOD, phytoplankton, zooplankton, organic and inorganic nitrogen, phosphorous, coliform bacteria, toxic substances and hydrodynamic conditions.	Two Dimensional multi-segment model
TIDEP (Turbulent diffusion temperature model reservoirs)	Horizontal temperature homogeneity Coefficient of vertical turbulent diffusion constant for charge of area with depth negligible coefficient of thermal exchange constant Data required wind speed, air temperature, air humidity, net incoming radiation, surface water temperature, heat exchange coefficients and vertical turbulent diffusion coefficients.	Steady state model
BIOLAKE	Model estimates potential fish harvest from a take	Steady state model
Estuary models/ estuarial Dynamic model	It is simulates tides, currents, and discharge in shallow, vertically mixed estuaries excited by ocean tides, hydrologic influx, and wind action Tides, currents in estuary are simulated	Dynamic model
Dynamic Water Quality Model	It simulates the mass transport of either conservative or non-conservative quality constituents utilizing	Dynamic model

Model	Application	Remarks
	information derived from the hydrodynamic model Bay-Delta model is the programme generally used. Up to 10 independent quality parameters of either conservative or non-conservative type plus the BOD-DO coupled relationship can be handled	
HEC -2	To compute water surface profiles for steady, gradually: varying flow in both prismatic & non-prismatic channels	
SMS	Lake circulation, salt water intrusion, surface water profile simulation model	Surface water Modeling system Hydrodynamic model
RMA2	To compute flow velocities and water surface elevations	Hydrodynamic analysis model
RMA4	Solves advective-diffusion equations to model up to six non-interacting constituents	Constituent transport model
SED2D-WES	Model simulates transport of sediment	Sediment transport model
HIVEL2D	Model supports subcritical and supercritical flow analysis	A 2-dimensional hydrodynamic model
MIKE-II, DHI	Model supports, simulations of flows, water quality, and sediment transport in estuaries, rivers, irrigation systems, channels & other water bodies	Professional Engineering software package

Table 5: Choice of Models for Impact Modeling: Biological Environment*

Name	Relevance	Applications	Remarks
Flora			
Sample plot methods	Density and relative density	Average number of individuals species per unit area	The quadrant sampling technique is applicable in all types of plant communities and for the study of submerged, sessile (attached at the base) or sedentary plants
	Density and relative dominance	Relative degree to which a species predominates a community by its sheer numbers, size bulk or biomass	
	Frequency and relative frequency importance value	Plant dispersion over an area or within a community	Commonly accepted plot size: 0.1 m ² - mosses, lichens & other mat-like plants
		Average of relative density, relative dominance and relative frequency	0.1 m ² - herbaceous vegetation including grasses
			10.20 m ² – for shrubs and saplings up to 3m tall, and
			100 m ² – for tree communities

Name	Relevance	Applications	Remarks
Transects & line intercepts methods	Cover	Ratio of total amount of line intercepted by each species and total length of the line intercept given its cover	This methods allows for rapid assessment of vegetation transition zones, and requires minimum time or equipment of establish
	Relative dominance	It is the ratio of total individuals of a species and total individuals of all species	Two or more vegetation strata can be sampled simultaneously
Plot-less sampling methods	Mean point plant Mean area per plant	Mean point – plant distance Mean area per plant	Vegetation measurements are determined from points rather than being determined in an area with boundaries
	Density and relative density		Method is used in grass-land and open shrub and tree communities
	Dominance and relative dominance		It allows more rapid and extensive sampling than the plot method
	Importance value		Point- quarter method is commonly used in woods and forests.
Fauna			
Species list methods	Animal species list	List of animal communities observed directly	Animal species lists present common and scientific names of the species involved so that the faunal resources of the area are catalogued
Direct Contact Methods	Animal species list	List of animals communities observed directly	This method involves collection, study and release of animals
Count indices methods (Roadside and aerial count methods)	Drive counts Temporal counts	Observation of animals by driving them past trained observers	Count indices provide estimates of animal populations and are obtained from signs, calls or trailside counts or roadside counts
	Call counts	Count of all animals passing a fixed point during some stated interval of time	These estimates, through they do not provide absolute population numbers, Provide an index of the various species in an area
			Such indices allow comparisons through the seasons or between sites or habitats
Removal methods	Population size	Number of species captured	Removal methods are used to obtain population estimates of small mammals, such as, rodents through baited snap traps
Market	Population size	Number of species originally	It involves capturing a portion of the population and at some later date

Name	Relevance	Applications	Remarks
capture methods	estimate (M)	marked (T) Number of marked animals recaptured (t) and total number of animals captured during census (n) $N = nT/t$	sampling the ratio of marked to total animals caught in the population

Table 6: Choice of Models for Impact Predictions: Socio-economic Environment*

Relevance		
Name	Application	Remarks
Extrapolative Methods	A prediction is made that is consistent with past and present socio-economic data, e.g. a prediction based on the linear extrapolation of current trends	
Intuitive Forecasting (Delphi techniques)	Delphi technique is used to determine environmental priorities and also to make intuitive predictions through the process of achieving group consensus	Conjecture Brainstorming Heuristic programming Delphi consensus
Trend extrapolation and correlation	Predictions may be obtained by extrapolating present trends Not an accurate method of making socio-economic forecasts, because a time series cannot be interpreted or extrapolated very far into the future with out some knowledge of the underlying physical, biological, and social factors	Trend breakthrough precursor events correlation and regression
Metaphors and analogies	The experience gained else where is used to predict the socio-economic impacts	Growth historical simulation commonsense forecasts
Scenarios	Scenarios are common-sense forecasts of data. Each scenario is logically constructed on model of a potential future for which the degrees of "confidence" as to progression and outcome remain undefined	Common-sense
Dynamic modeling (Input- Out model)	Model predicts net economic gain to the society after considering all inputs required for conversion of raw materials along with cost of finished product	
Normative Methods	Desired socio-economic goals are specified and an attempt is made to project the social environment backward in time to the present to examine whether existing or planned resources and environmental programmes are adequate to meet the goals	Morphological analysis technology scanning contextual mapping - functional array - graphic method Mission networks and functional arrays decision trees & relevance trees matrix methods scenarios

* **NOTE:** Project-specific proposed prediction tools need to be identified by the project proponent and shall be incorporated in the draft ToR to be submitted to the Authority for the consideration and approval by the concerned EAC/SEAC.

ANNEXURE X

**Form through which the State Governments/Administration of
the Union Territories Submit Nominations for SEIAA and SEAC
for the Consideration and Notification by the
Central Government**

Form for Nomination of a professional/expert as Chairperson / Member / Secretary of the SEIAA / EAC / SEAC						
1 Name (in block letters)						
2 Address for communication						
3 Age & Date of Birth (Shall be less than 67 years for the members and 72 years for the Chairman)						
4 Area of Expertise (As per Appendix VI)						
Professional Qualifications (As per Appendix VI)		Qualification(s)	University	Year of passing	Percentage of marks	
5						
6 Work experience (High light relevant experience as per Appendix VI)		Position	Years of association From to		Period in years	Nature of work. If required, attach separate sheets
7 Present position and nature of job		Serving Central / State Government Office?			Yes/No	
		Engaged in industry or their associations?			Yes/No	
		Associated with environmental activism?			Yes/No	
		If no is the answer for above three, please specify the present position and name of the organization				
8 Whether experienced in the process of prior environmental clearance?		Yes/No. If yes, please specify the experience in a separate sheet (Please restrict to 500 words)				
9 Whether any out-standing expertise has been acquired?		Yes/ No If yes, please provide details in a separate sheet (Please restrict to 500 words).				
10 Any other relevant information?		May like to attach separate sheets (Research projects, consultancy projects, publications, memberships in associations, trainings undergone, international exposure cum experience etc.)				

The Government of.....is pleased to forward the Nomination of Dr./Sh. for the position of Chairperson / Member / Secretary of the SEIAA / SEAC / EAC to the Ministry of Environment & Forests, the Government of India for the Notification.

(Authorized Signature with Seal)

ANNEXURE XI
Composition of EAC/SEAC

Composition of the EAC/SEAC

The Members of the EAC shall be Experts with the requisite expertise and experience in the following fields /disciplines. In the event that persons fulfilling the criteria of “Experts” are not available, Professionals in the same field with sufficient experience may be considered:

- Environment Quality Experts: Experts in measurement/monitoring, analysis and interpretation of data in relation to environmental quality
- Sectoral Experts in Project Management: Experts in Project Management or Management of Process/Operations/Facilities in the relevant sectors.
- Environmental Impact Assessment Process Experts: Experts in conducting and carrying out Environmental Impact Assessments (EIAs) and preparation of Environmental Management Plans (EMPs) and other Management plans and who have wide expertise and knowledge of predictive techniques and tools used in the EIA process
- Risk Assessment Experts
- Life Science Experts in floral and faunal management
- Forestry and Wildlife Experts
- Environmental Economics Expert with experience in project appraisal

ANNEXURE XII

Best Practices & Latest Technologies available and reference

Technological Aspects

Cleaner technologies

a) Modified wet quenching

CSQ is an advanced wet quenching system with low environmental impact. It was developed as an environmental friendly alternative to CDQ. The emissions of dust are as low as for a CDQ, the gaseous emissions are even less. Investment, O&M costs are substantially lower. The process itself is a combination of bottom and top quenching, providing extreme short cooling time.

Energy/Environment/Cost/Other Benefits:

- No energy recovery is possible
- Emission of less than 10g of particles per ton of coke has been reached
- Cost is low

b) Coke dry quenching

Coke dry quenching is an alternative to the traditional wet quenching of the coke. It reduces dust emissions, improves the working climate, and recovers the sensible heat of the coke. Hot coke from the coke oven is cooled in specially designed refractory lined steel cooling chambers by counter-currently circulating an inert gas media in a closed circuit consisting of a cooling chamber, a dust collecting bunker, a waste heat boiler, dust cyclones, a mill fan, a blowing device (to introduce the cold air from the bottom) and circulating ducts. Dry coke quenching is typically implemented as an environmental control technology. Various

systems are used in Brazil, Finland, Germany, Japan and Taiwan, but all essentially recover the heat in a vessel where the coke is quenched with an inert gas (nitrogen). The heat is used to produce steam, which may be used on-site or to generate electricity. It is now adopted in India in a big way for Greenfield steel plants.

Energy/Environment/Cost/Other Benefits:

- Energy recovered is approximately 400-500 kg steam/t, equivalent to 800-1200 MJ/t coke. Others estimate energy conservation through steam generation (0.48t/t coke). Electricity generation.
- New plant costs are estimated to be \$50/t coke, based on the construction costs of a recently built plant in Germany; retrofit capital costs depend strongly on the lay-out of the coke plant and can be very high, up to \$70 to \$90/GJ saved
- Decreased dust, CO₂ and SO_x emissions
- Increased water efficiency
- Better quality coke produced, improved strength of coke by 4%

c) Coal moisture control

Coal Moisture Control (CMC) operation has been introduced in coke manufacturing process in Japan. This process is aiming at decreasing the quantity of heat consumption for carbonization, improving the coke quality and raising the productivity by decreasing moisture content in coal charge. Although CMC operation offers such advantages, the negative aspect is carbon deposits on the coke oven chamber, which is under study.

Coal moisture control uses the waste heat from the coke oven gas to dry the coal used for coke making. The moisture content of coal varies, but it is generally around 8-9% for good coking coal. Drying further reduces the coal moisture content to a constant 3-5%, which in turn reduces fuel consumption in the coke oven. The coal can be dried using the heat content of the coke oven gas or other waste heat sources.

Energy/Environment/Cost/Other Benefits:

- Fuel savings of approximately 0.3 GJ/t
- Coal moisture control costs for a plant in Japan were \$21.9/t of steel
- Coke quality improvement (about 1.7%)
- Coke production increase (about 10%)
- Shorter cooking times
- Decrease in water pollution (ammonia reduction)

d) High pressure ammonia liquor aspiration system (HPALA)

The HPALA system is effective for controlling charging emissions in coke oven batteries. This is very popular in India. In this system, the ammoniacal liquor, which is a byproduct in the coke oven, is pressurized to about 35-40 bar and injected through special nozzles provided in the gooseneck at the time of charging. This creates sufficient suction inside the oven, thereby retaining pollutants from being released into the atmosphere. The system consists of high-pressure multistage booster pumps, sturdy pipe-work, specially designed spray nozzles, suitable valves and control instruments.

Energy/Environment/Cost/Other Benefits:

- Emissions control
- High reliability and simplicity of operation
- Low operational and maintenance costs
- Appreciable saving in quantity of process steam required and increased raw gas yield/byproducts generation, due to elimination of gases vented into the atmosphere

e) Modern leak-proof door

Coke oven leaking doors can be a major source of pollution. With the advent of recovery type ovens, the design of oven doors has gone through a process of evolution, beginning from luted doors to the present generation self-regulating zero-leak doors. Such doors are now available in India and are being installed by many steel plants. The important features of the leak-proof door include: (1) a thin stainless steel diaphragm with a knife edge as a sealing frame built in between the door body and the brick retainer, (2) spring loaded regulation on the knife edge for self-sealing, (3) provision for air cooling of the door body, and (4) large size gas canals for easier circulation of gas inside oven.

Energy/Environment/Cost/Other Benefits:

- Minimisation of door leakage
- Regulation free operation
- Longer life due to less warping of the air cooled door body
- Reduced maintenance frequency
- Conventional doors can be replaced by leak-proof doors without altering battery/door frame Design Ikio design Simplex doors have achieved a PLD of 1% against the CPCB norm of 5% while retrofitted at Battery 3 of BSP in India.

f) Land-based pushing emission control system

The smoke and fumes produced during the pushing of red hot coke contains a huge amount of coke dust (estimated at 11% of the total pollution in the coke oven). Land-based pushing emission control systems mitigate this pollution. New steel plants in India are installing this system as technology is now available. It consists of three parts: (1) a large gas suction hood fixed on the coke guide car and moving with the coke guide, sending fumes to the coke side dust collecting duct; (2) the dust collection duct; and (3) the final equipment for smoke purification on the ground (ground piping, accumulator cooler, pulse bag dust collector, silencer, ventilation unit, stack, *etc*). The large amount of paroxysmal high-temperature smoke produced during coke discharging is collected under the hot float fan into the large gas suction hood installed in the coke guide car, and enters the dust collection duct through the other equipment.

The air is dissipated into the atmosphere after purification by the pulse dust collector and after being cooled by the accumulator cooler. The total de-dusting system is controlled by PLC.

Energy/Environment/Cost/Other Benefits:

- Elimination of pushing emission up to a large extent

g) Advanced technologies for desulphurization of coke oven gas

Because of hydrogen sulphide (H_2S) content up to 9 g/Nm^3 in unpurified coke oven gas, it is unsuited for use in many industrial applications. $3.5 - 4.5 \text{ g/Nm}^3$ is observed in Indian coke oven plants. Also, as per the MoEF guidelines, the sulphur content in coke oven gas used for heating should be limited to 800 mg/Nm^3 . When the gas has been desulphurized, its use for a variety of applications becomes potentially viable. Among many processes, Wet Oxidation Process (Stratford process) and Absorption/Stripping Process (ASK or Diamex process) described here can reduce H_2S content satisfactorily. In Stratford process, H_2S is scrubbed from the coke oven gas by a sodium carbonate solution (Na_2CO_3) and elemental sulphur (S^0) is yielded using vandate (VO_3) as an intermediate. Regeneration of the scrubbing liquid takes place by aeration (O_2), using anthraquinone disulphonic acid (ADA) as an intermediate. In ASK or Diamex process, H_2S is scrubbed from the coke oven gas by a NH_3 solution. The NH_3 solution is derived from the NH_3 scrubber. The H_2S and NH_3 are stripped from the washing liquor by steam stripping and the vapours are led to a Claus plant or a Sulphuric Acid plant.

Energy/Environment/Cost/Other Benefits:

- H_2S reduction up to 2 mg/Nm^3 is possible in wet oxidation process.
- In absorption process, H_2S reduction up to 500 mg/Nm^3 is possible.
- Annual debt service on capital cost is around 11% and annual maintenance on capital cost is around 4% in both the cases.

Pollution control technologies

a) Recovery type coke oven battery

The recovery type coke oven plant is the source of pollution of the air and water. Air pollutants cover dusts and chemical substances. Non-process dust is generated from open stock piles, coal handling and coke sorting plants. Process dust is generated from battery during coal charging, coke pushing, coke transfer to quenching towers and coke dry quenching, if provided. Along with process dusts, chemicals like hydrogen sulphide, sulphur dioxide, carbon monoxide, pyridine bases, aromatic hydrocarbons, phenols, ammonia, naphthalene, carbon disulphide, 3, 4 benzopyrene, hydrocyanic acid and other compounds are generated.

Non-process dust during coal handling and coke sorting are controlled by providing dust extraction systems. Due to explosive nature of coal dust, utmost precautions are to be taken while selecting a dry dust catching plant. Wet scrubbers are safe, but the problem is generation of effluents which need to be treated. Bag filters of spark proof type are also installed. Dust suppression systems by spraying water at the source with or without additives and dry fog systems have become popular. However, it has limitations that it cannot be sprayed when the material is hot. Dust suppression systems are most useful for open stock piles where dust extraction systems cannot be installed.

Process dust during coke pushing along with fumes can be extracted by specially designed moving hoods located over guide car and quenching cars connected to stationary land based pollution control equipment, which is fabric filter with section to catch tar in the fume. The smoke and fumes produced during the pushing of red hot coke contains a huge amount of coke dust (estimated at 11% of the total pollution in the coke oven). Land-based pushing emission control systems mitigate this pollution. It consists of three parts: (1) a large gas

suction hood fixed on the coke guide car and moving with the coke guide, sending fumes to the coke side dust collecting duct; (2) the dust collection duct; and (3) the final equipment for smoke purification on the ground (ground piping, accumulator cooler, pulse bag dust collector, silencer, ventilation unit, stack, *etc.*). The large amount of paroxysmal high-temperature smoke produced during coke discharging is collected under the hot float fan into the large gas suction hood installed in the coke guide car, and enters the dust collection duct through the other equipment.

The air is dissipated into the atmosphere after purification by the pulse dust collector and after being cooled by the accumulator cooler. The total de-dusting system is controlled by PLC.

Process dust and fume during coal charging emitting through charging lids can be controlled by creating negative pressure in the battery during coal charging. This is done by HPALA systems. The HPALA system is effective for controlling charging emissions in coke oven batteries. In this system, the ammoniacal liquor, which is a byproduct in the coke oven, is pressurized to about 35-40 bar and injected through special nozzles provided in the gooseneck at the time of charging. This creates sufficient suction inside the oven, thereby retaining pollutants from being released into the atmosphere. The system consists of high-pressure multistage booster pumps, sturdy pipe-work, specially designed spray nozzles, suitable valves and control instruments.

Chemical substances leaking from battery can be controlled only by reducing leakages. It is practically impossible to locate suction hoods from various leaking parts of the battery like doors, lids, off-takes, *etc.*, when these are opened or when these leak. As such, coke oven leaking doors can be a major source of pollution. With the advent of recovery type ovens, the design of oven doors has gone through a process of evolution, beginning from luted doors to the present generation self-regulating zero-leak doors. The important features of the leak-proof door include:

- a thin stainless steel diaphragm with a knife edge as a sealing frame built-in between the door body and the brick retainer,
- spring loaded regulation on the knife edge for self-sealing,
- provision for air cooling of the door body, and
- large size gas canals for easier circulation of gas inside oven.

The wastewater effluents contain various organic compounds such as phenols, ammonia and cyanide. These can be treated in a BOD plant through microorganisms.

Waste minimization and pollution prevention in by – product plant

Usage of caustic soda rather than lime in the ammonia still; though more costly, it minimises sludge formation, reduces down time due to scaling problems, and may solve disposal problems.

- Indirect cooling of the coke oven gas to eliminate any contact of the process water with pollutants in the coke oven gas with the exception of flushing liquor.
- Elimination of the recovery of naphthalene and the naphthalene sump.
- The use of an indirect type system for light oil recovery eliminates process waste water steams since no water comes into contact with the gas, the wash oil, the light oil or the final cooler.

- All pumping stations, oil storage tanks and oil transfer points should be located on impervious, dyked pads with the pad effluent directed to the waste ammonia liquor steam for treatment in order to prevent contamination of ground water.
- The wet oxidation sulfur removal processes for coke oven gas has created highly contaminated waste water streams. Alternative processes like Zimpro Modified Wet Air Oxidation Process, the Dofasco Fixed Salts Recovery Process, or the Nippon Steel HIROHAX process exists.
- Tar by products should be recycled in-plant after processing (*e.g.*, for use as a fuel) or sold as a by-product.
- The sludge generated by the biological treatment system can be recycled to the coke oven.
- Tar decanter sludge can be circulated through a solvent grinding pump and then sprayed onto the coal prior to charging into oven.

b) Non-recovery type coke oven battery

The pollution problem from such batteries are low due to the fact that the batteries work under slight negative pressure unlike recovery type batteries, which work under slight positive pressure. As such, emission of pollutants from battery is eliminated. Also, as the COG is completely combusted inside the battery, organic pollutants like PAH are fully broken down. As there is no by-product plant, liquid effluents and a BOD plant are avoided. Solid wastes are completely avoided as there are no crude tar and benzol involved.

Environmental, occupational health and safety problems and mitigation measures for non-recovery beehive type batteries include:

- Battery being charged manually from top while it is still hot causes inhalation of emissions. Coal charging may be mechanized for safe guarding health of workers.
- Manual jobs like – pushing and pulling of coke on wharf after quenching and water spraying using hose pipes – cause health and safety problems due to inhalation of carcinogenic fumes. Mechanization of pushing, pulling and spraying can avoid workers' exposure to heat and steam.
- Combusted coke oven gas is often let off without effective cleaning of dust and fumes. High efficiency battery cyclones with exhaust fans may have pollution problems.
- Coal handling and coke sorting plants are usually without effective dedusting systems. Dust and fume extraction systems at transfer points can avoid air pollution.
- Foundry industry requires coke and same is catered by the small beehive batteries. Tiny size and lack of technological updations are the prevailing causes for pollution from the beehive batteries. However, these tiny beehive plants shall also update their technological provisions in order to meet the desired norms *i.e.*:
 - particulate emissions - 150 mg/m^3
 - Work zone norm of 10 mg/m^3 for dust

Best operating practices

The industry may initiate the following clean technologies/measures to improve the performance of industry towards production, energy, environment and occupational health and safety.

- Mechanisation of operations to prevent exposure to heat and inhalation of emissions such as battery charging from top, coke pushing, pulling and spray of water by hose pipes.
- Providing exhaust fans, high efficiency battery cyclones, discharging combusted coke oven gas after effective cleaning.
- Effective dedusting of coal handling & coke sorting plants and providing dust & fume extraction systems at transfer points.
- Installation of continuous stack monitoring system and its calibration in major stacks and setting up of online ambient air quality monitoring stations
- Charge of tar sludge/ETP sludge to coke oven
- Operating CO-BP ETP efficiently to achieve the notified effluent discharge standards
- Implementing rainwater harvesting
- Efficient usage of existing pollution control equipment to keep proper record of run hours, failure time and efficiency
- Reduction of Green House Gases by:
 - Reduction in power consumption
 - Use of by-products gases for power generation
 - Promotion of energy optimization technology including energy audit
- To set targets for resource conservation such as raw material, energy and water consumption to match International Standards.
- Upgrading the monitoring and analysis facilities for air and water pollutants. Also to impart elaborate training to the manpower so that realistic data is obtained in the environmental monitoring laboratories.
- To Improve overall house keeping.

REFERENCES

Documents

- **Ministry of Environment and Forest, GoI** – “Environment Impact Assessment Notification” S.O.1533 dated 14th September 2006.
- **Ministry of Environment and Forest, GoI** – “Environment Impact Assessment Notification 2006 – Amendment” S.O. 195 (E) dated 1st December, 2009.
- **Ministry of Environment and Forest, GoI** – Charter on Corporate Responsibility for Environment Protection Action Points for 17 Categories of Industries, CPCB, March 2003.
- **Larry W. Canter**, “Environmental Impact Assessment”, Second Edition, McGraw Hill, University of Oklahoma, 1997.
- **European Commission - Integrated Pollution Prevention and Control (IPPC):** Best Available Techniques Reference Document on the Production of Iron and Steel December 2001.
- **International Association for Impact Assessment** – “Principles of Environmental Impact Assessment Best Practice”, Institute of Environmental Assessment, UK.
- **International Finance Corporation** – “Environmental, Health and Safety Guidelines for Integrated Steel Mills”, World Bank Group, April 30, 2007.
- **World Bank Group** –“Pollution Prevention and Abatement Handbook on Coke Manufacturing” effective July 1998.
- **United States Environmental protection Agency** – Economic Impact Analysis of Proposed Coke Ovens NESHAP
- **United States Environmental protection Agency** – **Coke Ovens: Industry Profile** : Prepared for Daniel C. Mussatti
- **“Added Value Long Steel Products produced at MSSA Newcastle Works”** – V. Scholtz, D.S. Magudulela, F. van Zyl, A. Coetzee, A. Humpel, C. Hill, and A.J. Potgieter.
- **Coke Production For Blast Furnace Ironmaking** – By Hardarshan S. Valia, Scientist, Ispat Inland Inc
- **Heat-Recovery Cokemaking Presentation** – Rick Waddell, Richard Westbrook, Sun Coke Co.
- **Multilateral Investment Guarantee Agency** – “ Environmental Guidelines for Coke Manufacturing”
- **Products and by-products of Coal** – By Edger stansfield
- **The Coke Oven By-Product Plant** – Contributed by Mick Platts, ThyssenKrupp EnCoke USA

Websites

- <http://envfor.nic.in/divisions/iass/eia.htm>
- <http://www.cpcb.nic.in/>
- <http://www.epa.gov/>
- <http://www.iaia.org>
- <http://www.bhamrails.info/index.htm>
- <http://www.cfriindia.nic.in/>
- <http://www.epa.gov/ttnchie1/ap42/ch12/index.htm>



IL&FS Ecosmart Limited
Flat # 408, Saptagiri Towers
Begumpet
Hyderabad – 500 016
Ph: + 91 40 40163016
Fax: + 91 40 40032220

For any queries or technical inputs kindly mail:

sateesh.babu@ifsecosmart.com

suman.thomas@ifsecosmart.com